

# FALCON RIDGE NORTH TENTATIVE MAP



Prepared by:



August 15, 2019

# **FALCON RIDGE TENTATIVE MAP**

**Prepared for:**

Desert Winds Homes  
550 California Avenue  
Reno, NV 89509

**Prepared by:**

Rubicon Design Group, LLC  
1610 Montclair Avenue, Suite B  
Reno, Nevada 89509  
(775) 425-4800

**August 15, 2019**

**Table of Contents**

Introduction .....1  
Project Location .....1  
Existing Conditions.....2  
Previous Entitlements and Land Use Designations .....3  
Request Summary .....5  
Common Open Space Development .....9  
Potential Impacts .....14  
Planning Policy Analysis .....15  
Tentative Map Findings .....17

**List of Figures:**

Figure 1 – Vicinity Map .....1  
Figure 2– Existing Conditions .....2  
Figure 3 – Master Plan Designation .....3  
Figure 4 – Zoning.....4  
Figure 5 – Preliminary Site Plan .....6  
Figure 6 – Preliminary Building Elevations .....8

**Appendix and Accompanying Documents**

- TM Application Form and Checklists
  - Owner Affidavit
  - Proof of Property Tax Payment
  - TMWA Intent to Serve Letter
  - 24x36 Color Landscape Plan
  - 24x36 Engineering Plans
  - 24x36 Architectural Elevations
  - 8.5x11 Copies of Above Exhibits
  - Sanitary Sewer Report
  - Hydrology Report
  - Geotechnical Report
-

# FALCON RIDGE NORTH TENTATIVE MAP

## Introduction

This application includes the following request:

- A **Tentative Subdivision Map** to create 52 single family lots, with common open space, on 6.19± acres within the Sun Valley Area Plan.

## Project Location

The Falcon Ridge North site (APN 035-721-02) consists of 6.19± acres and is located near the south end of the Sun Valley Area Plan. Specifically, the property is located on the north side of El Rancho Drive and east of Sun Valley Blvd. Figure 1 (below) depicts the project location.



Figure 1 – Vicinity Map

### Existing Conditions

Currently, the project site is vacant. Surrounding land uses are: open space to the north and east, single family housing to the south, and apartments to the west.

Property to the south is the Falcon Ridge subdivision, currently under construction. This new project is a continuation of the Falcon Ridge subdivision and was planned and approved as part of the Falcon Ridge Specific Plan.

The property contains moderate slopes, rising from south to north. Portions of the site have been informally graded in the past and have been used for dirt storage from other projects. These disturbed areas will be properly engineered and landscaped with this new project.

The property is accessed from the Falcon Ridge project. Figure 2 shows the existing onsite conditions.



View of property looking north from Falcon Ridge subdivision

**Figure 2 – Existing Conditions**

## FALCON RIDGE NORTH TENTATIVE MAP

### Previous Entitlements and Land Use Designations

Falcon Ridge North is located within the Sun Valley Area Plan and is included in the Falcon Ridge Specific Plan. This Specific Plan identifies the site as intended for single family and/or multi family development. This project is a continuation of this approved Specific Plan.

The overall Falcon Ridge Specific Plan area has received approvals for previous tentative maps and final maps. The majority of the area is currently under construction in conformance with these maps. These previous approvals included grading of the Falcon Ridge North parcel. The bulk of the site is graded flat and retaining walls have been installed. This project will continue this previously approved grading in accordance with the existing Conditions of Approval.

The site has a Master Plan designation of Urban Residential (UR) and is zoned Low Density Urban (LDU) across the entire Specific Plan. Per the Washoe County Master Plan (LUTE, p. 50), the LDU zone conforms to the UR designation. Figures 3 and 4 show the designations for the site.

Note that no amendment to the Master Plan or zoning is being requested with this application.

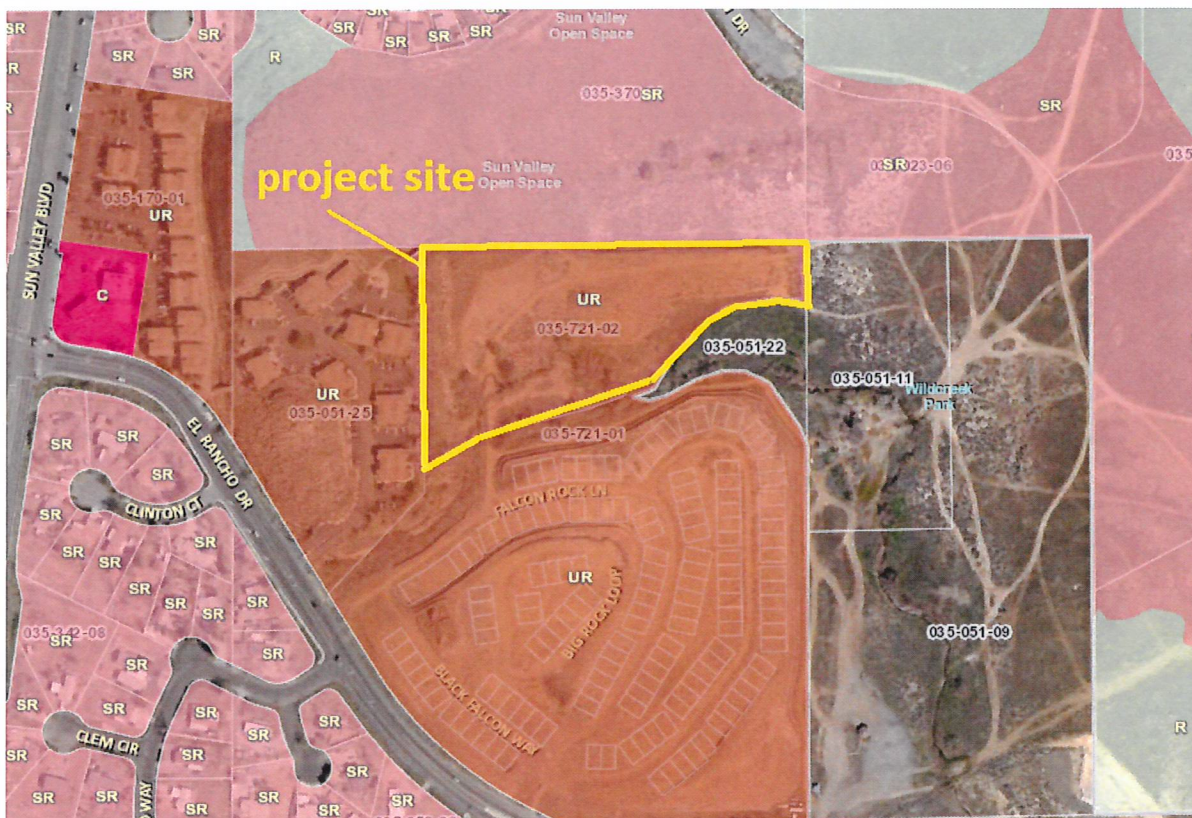

Figure 3 – Master Plan Designation

## FALCON RIDGE NORTH TENTATIVE MAP

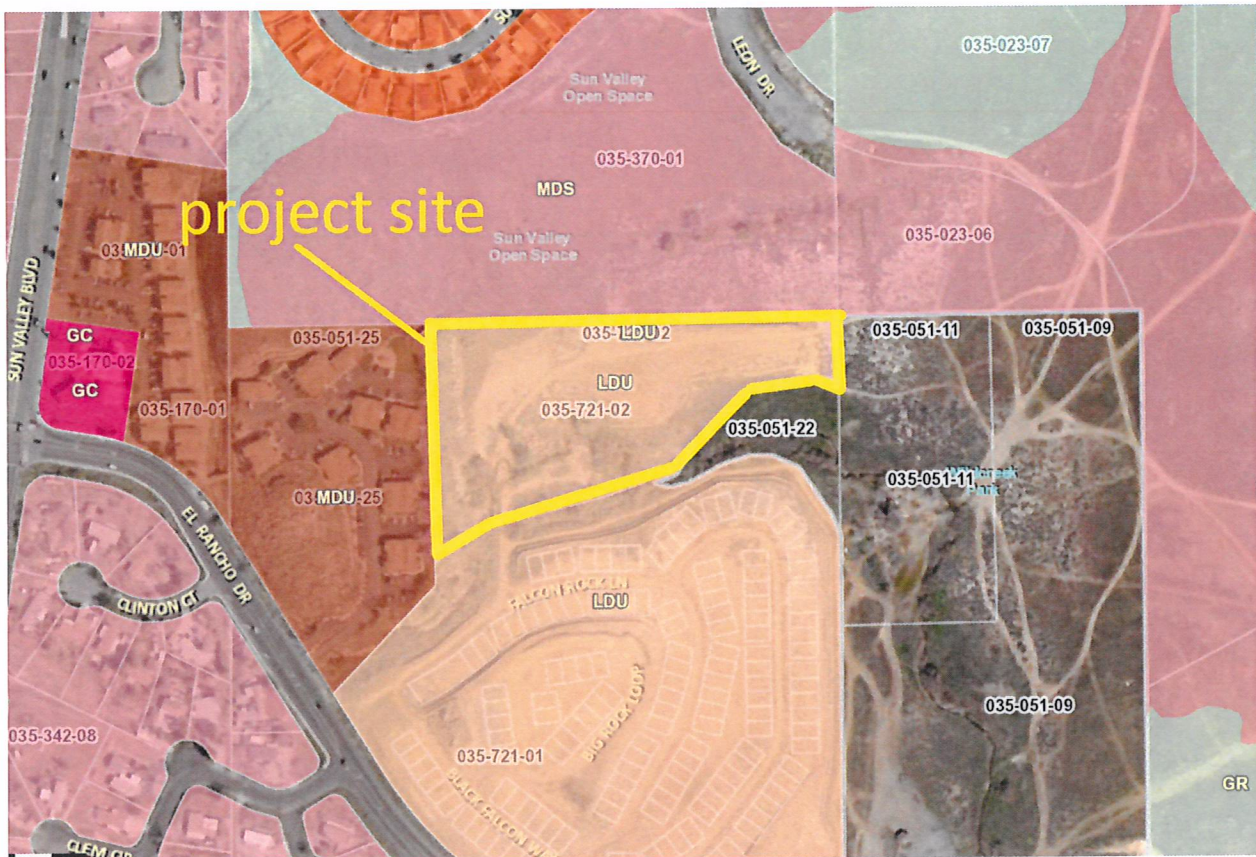

Figure 4 – Zoning

*Section 110.106.15 Regulatory Zones*, of the Washoe County Development Code identifies the maximum density of the Low Density Urban zone as: *ten (10) units per one (1) acre for single-family; fourteen (14) units per one (1) acre for multi-family; and twelve (12) units per one (1) acre for mobile home parks.*

Given the project area of 6.19 acres, the maximum allowed buildout would be 61 units. The project proposes 52 units and is therefore within the allowed density.

The zoning of the project site is the same as on the rest of the Falcon Ridge Specific Plan area. This project proposes development that is consistent with the earlier approvals both in density and in appearance. The proposed project is therefore directly compatible with the Master Plan, the zoning, and with the Specific Plan.

**Request Summary**

This application includes a Tentative Subdivision Map request to create 52 attached single family lots at the project site. It is planned to develop Falcon Ridge North utilizing a Common Open Space Development approach, per the standards contained in Article 408 of the Washoe County Development Code.

The plan developed for Falcon Ridge North includes 52 lots for an overall density of 8.4 units per acre. Included within the project are 4.69± acres of common area. This common area includes roads, walkways, and open space. This generous open space area allows the steeper sections of the site to remain undisturbed. This is primarily seen in the northwest corner of the property where no development or grading is proposed.

This common area also allows for safe, convenient street dimensions. For the main roadway within Falcon Ridge North (Street 1 on plans), there will be sidewalks on both sides. For the shorter Street 2, sidewalk is only planned for the north side as there are no houses on the south side of this street.

The project is too small to contribute to regional recreational amenities but it will be possible for residents to access area open space at the northeast corner of the site. Informal walking paths extend offsite toward Wildcreek Park from the project.

Falcon Ridge North will contain two housing footprints. Lots 1-22 have a footprint of 960 square feet. Lots 23-52 are 1,477 square feet. Lots 1-22, along the northern and western property edge, will be graded into the hill to allow for appropriate driveway grades and finish floor elevations. Lots 23-52 will be located on areas that are substantially graded already and minimal additional grading is required for these units.

Lot sizes within Falcon Ridge North are consistent with the LDU zoning and are complementary to the existing Falcon Ridge subdivision to the south. The project is also compatible with the existing multi-family development to the west. The table below provides project data. Figure 5 (following page) shows the proposed site plan.

| <b>Item</b>        | <b>Units</b>      |
|--------------------|-------------------|
| Housing            | 52 lots           |
| Lot Area           | 1.50 acres        |
| Common Area        | 4.69 acres        |
| Project Size       | 6.19 acres        |
|                    |                   |
| Smallest House Lot | 960 square feet   |
| Largest House Lot  | 1,477 square feet |
| Average Lot Size   | 1,258 square feet |



# FALCON RIDGE NORTH TENTATIVE MAP



Figure 5 – Preliminary Site Plan

## FALCON RIDGE NORTH TENTATIVE MAP

---

As seen in Figure 5, the project matches the development pattern of the rest of Falcon Ridge to the south. A homeowners association (HOA) will be created for Falcon Ridge North with the approval of the first final map. The HOA will be responsible for maintaining the open space and common areas and for enforcement of planned covenants, conditions, and restrictions (CC&R's). CC&R's will be developed for the site to ensure that homeowners maintain their properties and that the community vision is carried forward. The HOA may choose to form its own architectural review committee in order to further regulate any proposed modifications to homes (i.e. additions, patio covers, detached garages, etc.). Of course, any modification to the approved home plans would require compliance with the Falcon Ridge Specific Plan zoning standards (i.e. setbacks, etc.) and would be subject to review and approval by Washoe County. The CC&R's are not enforced by the County but will provide the HOA with a mechanism to enforce the community standards and vision. The CC&R's will be provided to new home buyers at the time of purchase and will be recorded against new lots within Falcon Ridge North.

Primary access will be provided through the Falcon Ridge project, which in turn connects to El Rancho Drive at the El Rancho/Falcon Rock Lane intersection. Falcon Rock Lane loops through Falcon Ridge and provides an emergency access driveway onto El Rancho Drive at its western end. This secondary access is to include an emergency access gate at this western end, between Falcon Ridge and El Rancho Drive.

A traffic light is also planned for the existing El Rancho/Falcon Rock Lane intersection. This light will enhance safety for residents entering and existing the project area and for pedestrians crossing El Rancho Drive. Installation of this light is expected in the near future.

Roadways within Falcon Ridge North will be private and will match the already installed streets within Falcon Ridge. There are two street sections proposed. As shown on the attached plans, Street 1 includes a 4' sidewalk on each side of 26'-wide paved travel lanes. Street 2 is similar but with sidewalk on only one side. As there are no houses planned for the south side of Street 2, no sidewalk is needed there.

Complete buildout of the project will be somewhat dependent on market conditions but the developer intends to start as soon as possible. The project is planned to be built as a single phase. A final map will follow this tentative map process and bonding for improvements shall occur in accordance with Washoe County requirements and policies.

Home plans for Falcon Ridge North are still being developed but will be comparable to the existing units within Falcon Ridge. Consistent with Washoe County policy, final home plans and elevations will be subject to review for compliance with the Falcon Ridge Specific Plan. Figure 6 shows preliminary elevation concepts.

The overall Falcon Ridge project includes a gate at the main entrance on El Rancho Drive. This gate was designed as part of previous tentative maps for the area but will serve this project as well.

Fencing for the project will include six-foot wood fences for side and rear yards. These fencing requirements will also be included in the CC&R's recorded for Falcon Ridge North.

## FALCON RIDGE NORTH TENTATIVE MAP

---



Figure 6 – Preliminary Building Elevations

## **Common Open Space Development**

Article 408 of the Washoe County Development Code establishes regulations related to Common Open Space Developments (COSD). This complete code section is included below, with responses in **bold face** type.

*Section 110.408.00 Purpose. The purpose of this article, Article 408, Common Open Space Development, is to set forth regulations to permit variation of lot size, including density transfer subdivisions, in order to preserve or provide open space, protect natural and scenic resources, achieve a more efficient use of land, minimize road building, and encourage a sense of community.*

**The project conforms to this purpose by minimizing lot area in favor of open space and reduced grading.**

*Section 110.408.05 Applicability. Common open space development may be allowed in any residential land use category or any general, office or tourist commercial regulatory zone.*

**No response required.**

*Section 110.408.10 Applications. If the provisions of this article are utilized, the application for a tentative subdivision map or a parcel map, as provided in Division Six, shall state that a common open space development is proposed.*

**The application request states this and the common open space regulations are addressed in the report.**

*Section 110.408.15 Non-Residential Uses. Non-residential uses that serve the residents of a common open space development may be allowed provided they are allowed by, and meet the requirements of, Article 302, Allowed Uses, and are designed to be an integral part of the project.*

**There are no non-residential uses in this request.**

*Section 110.408.20 Density and Intensity.*

*(a) Residential. The total number of dwelling units in the proposed common open space development shall not exceed the total number of dwelling units allowed by the underlying regulatory zones(s). The gross site area may include more than one (1) parcel. (b) Non-Residential. The total amount of non-residential space shall not exceed the amount of space allowed by Article 106, Regulatory Zones, or Article 402,*

**Density of the proposed project conforms to the underlying zone. The LDU zone allows for a maximum of 10 units per acre for single family. This tentative map proposes a gross density of 8.4 units per acre.**

*Density/Intensity Standards. The amount of non-residential space may be further restricted if the Planning Commission finds that such restriction is necessary to preserve the primary residential character of the development.*

There are no non-residential uses in this request.

*(c) General. All development shall comply with the height standards in Table 110.406.05.1, Standards.*

The project conforms to this height limit of 35' for the LDU zone.

*Section 110.408.25 Lot and Yard Standards. The complete common open space development must comply with the minimum lot width, front yard setbacks, side yard setbacks, and rear yard setbacks in Table 110.406.05.1, Standards, or as an alternative, typical building envelopes shall be shown on the tentative subdivision map or parcel map where these standards are proposed to be varied below the minimum standard.*

The project is consistent with previously approved tentative maps for Falcon Ridge. The lot design is not standard County Code in that front yard areas are excluded from the individual lots. However, this design is consistent with the Falcon Ridge Specific Plan which is the governing document for the site. This design is also consistent with the previously approved sections of Falcon Ridge.

*Section 110.408.30 Site Analysis to Determine Common Open Space and Lot Size Variations. A site analysis showing development opportunities and constraints shall be prepared as a key consideration, along with the project design objectives, to determine the total area covered by lots and roads, lot areas, and the total area to be designated as common open space. The site analysis shall include information and maps, including a site opportunities and constraints map, describing all significant physical and contextual features or factors which may affect the development of the property. The elements of the site analysis shall include, as a minimum, the following information:*

*(a) Location Map. A general location map providing the context of location and vicinity of the site.*

Figure 1 (page 1) included in this report provides an overall location/vicinity map for Falcon Ridge North. Additionally, a vicinity map is also included on the Tentative Map Title Sheet in the attached map pocket.

*(b) Land Use. Current and planned land use on the site and adjacent current, planned and approved, but unbuilt land uses.*

As depicted in this report, the project site is currently vacant but has been graded in the past. The site is part of the Falcon Ridge Specific Plan and is zoned LDU. No changes to this zoning are included in this request. Property to the north is developed as single family homes with common open space, similar to what is proposed here. To the east is public open space and no development is anticipated. To the south is the rest of the Falcon Ridge development, currently under construction. Property to the west is developed with multi-family housing, at a more intense level than the proposed project.

*(c) Existing Structures. A description of the location, physical characteristics, condition and proposed use of any existing structures.*

Not applicable. There are no existing onsite structures.

- (d) Existing Vegetation. A description of existing vegetation, including limits of coverage, and major tree sizes and types. In the instance of heavily wooded sites, typical tree sizes, types and limits of tree coverage may be substituted.

The Falcon Ridge North site has been graded in the past under previous permits. The site is therefore mostly bare. There are some trees along the southern property edge, primarily in the drainage channel. These trees can remain in place with this project.

- (e) Prevailing Winds. An analysis of prevailing winds.

Prevailing winds in the area are from west to east with occasional northerly winds during storm events. The project is sheltered from these winds by existing topography, with higher slopes to the north and west.

- (f) Topography. An analysis of slopes on the site using contour interval of five (5) feet, or at a contour interval appropriate for the site and agreed to by the Director of Community Development.

The engineering plans included with this application depict the site topography. Slopes on the site were previously graded as part of prior project approvals associated with Falcon Ridge. This work was approved under and is consistent with the Falcon Ridge Specific Plan.

- (g) Soil. An analysis of the soil characteristics of the site using Soil Conservation Service (SCS) information.

A preliminary geotechnical report is included as an appendix to this report and identifies no soil or geologic conditions that would preclude residential development.

- (h) Natural Drainageways. Identification of natural drainageways on and adjacent to the site.

Natural drainage that occurs along the southern portion of the site will be retained and is incorporated into the provided open space. This is a partially natural and partially engineered drainageway and is identified on the included engineering plans. A detailed hydrology study is also included as an appendix to this report.

Note that refinements to the current FEMA mapping will occur as this site is analyzed further. The existing FEMA map data is highly general and needs to be analyzed using accurate data. This work is currently underway. The project does not propose any work in this drainageway. One component of the project design is to include enough open space area to allow for backwater flow from this drainageway, if necessary. The exact height of water within this drainageway will be refined through additional analysis.

- (i) Wetlands and Water Bodies. Identification of existing or potential wetlands and water bodies on the site.

The included plans identify the drainageway on the southern part of the site. The project has a permitted crossing of the drainageway on site, obtained as part of previous entitlements for the area. No additional work in this drainageway is planned.

(j) Flood Hazards. Identification of existing and potential flood hazards using Federal Emergency Management Agency (FEMA) information.

The drainageway across the southern portion of the site is classified as a flood hazard area. This area is incorporated into the open space and does not occur within any of the proposed lot areas. This area is also depicted on the engineering plans and addressed in the included hydrology report.

(k) Seismic Hazards. Identification of seismic hazards on or near the site, including location of Holocene faults.

A preliminary geotechnical report is included with this application. No known seismic hazards are identified.

(l) Avalanche Hazards. An analysis of avalanche and other landslide hazards.

Not applicable. There are no landslide areas on the site.

(m) Sensitive Habitat and Migration Routes. An analysis of sensitive habitat areas and migration routes.

Not applicable. There are no known or identified sensitive habitats or migration routes onsite.

(n) Significant Views. A description and analysis of all on and off-site significant views.

Views from the site generally are toward the south, which contains the Falcon Ridge project. The site sits lower than the surrounding developed parcels and therefore does not present an impact to existing views.

(o) Easements. A description of the type and location of any easements on the site.

All existing and proposed easements are clearly depicted on the engineering plans included with this report. Additionally, a preliminary title report is being submitted with the original report that identifies and describes all existing easements.

(p) Utilities. A description of existing or available utilities, and an analysis of appropriate locations for water, power, sanitary sewer and storm water sewer services.

The attached engineering plans and drawings depict all existing utilities/infrastructure and proposed extensions, etc. The project will connect to all municipal services including sewer, water, natural gas, cable television, etc.

(q) *Appropriate Access Points.* An analysis of appropriate access points based upon existing and proposed streets and highways and site opportunities and constraints.

**Access is provided from El Rancho Drive, through the Falcon Ridge project. Comprehensive traffic analysis occurred with the approval of the Falcon Ridge Specific Plan.**

(r) *Other Information.* All other information deemed appropriate and necessary by the Director of Community Development.

**This report provides for all pertinent and required details. Additional information and analysis can be provided on an as-needed basis as it may arise during the public review process.**

*Section 110.408.35 Roads.* To the extent possible, common roads and driveways shall be used for access. The roads shall be aligned to follow natural features and topography where possible.

**Proposed roads follow the existing grades. The project shares access with the rest of the Falcon Ridge project.**

*Section 110.408.40 Parking.* The parking requirements of Article 410, Parking and Loading, shall apply.

**The project meets the required parking standard, including the provision of 15 guest parking spaces distributed around the project area.**

*Section 110.408.45 Conditions of Approval.* Provisions for the common open space development shall be conditioned upon approval of the tentative subdivision or parcel map.

**The project will comply with this requirement.**

(a) *Three-Year Maintenance Plan.* Provisions shall be made to monitor and maintain, for a period of three (3) years regardless of ownership, a maintenance plan for the common open space area. The maintenance plan for the common open space area shall, as a minimum, address the following:

- (1) Vegetation management;
- (2) Watershed management;
- (3) Debris and litter removal;
- (4) Fire access and suppression;
- (5) Maintenance of public access and/or maintenance of limitations to public access; and
- (6) Other factors deemed necessary by the Planning Commission or the Board of County Commissioners.

**The project will maintain an HOA/LMA that will be responsible for common area management.**

(b) *Permanent Preservation and Maintenance.* Provisions shall be made for the permanent preservation and ongoing maintenance of the common open space and other common areas using a legal instrument



acceptable to the County.

**The project will maintain an HOA/LMA that will be responsible for common area management.**

*(c) Screening and Buffering of Adjoining Development. Provisions shall be made to assure adequate screening and buffering of existing and potential developments adjoining the proposed common open space development.*

**Surrounding property is generally higher than the project site. Therefore, the site is naturally screened from these adjoining properties because they look down on the project. Nonetheless, there is a generous open space area between the housing lots and the multi-family development to the west.**

*(d) Common Open Space Restrictions. Designated common open space shall not include areas devoted to public or private vehicular streets or any land which has been, or is to be, conveyed to a public agency via a purchase agreement for such uses as parks, schools or other public facilities.*

**The project conforms to this requirement.**

## **Potential Impacts**

This section provides an analysis of likely impacts from the project, based on the Tentative Map plans.

### **Traffic**

The project is modestly sized and will not have a significant impact on area traffic. Overall traffic impacts were analyzed during the approval of the Falcon Ridge Specific Plan and this tentative map is a continuation of that approval.

The 52 housing units of Falcon Ridge North are anticipated to generate 302 average daily trips, with 23 trips during the AM peak and 27 trips during the PM peak (ITE Trip Generation 9<sup>th</sup> Edition, Land use 230 Condo/Townhouse). Area streets can easily handle traffic generation of this magnitude.

### **Schools**

As part of this Tentative Map process, Washoe County School District information was reviewed. The project site is zoned for the following schools: Allen Elementary School, Traner Middle School, and Hug High School. Using WCSD student generation rates, the project is expected to generate: 9 high school students, 4 middle school students, and 4 elementary school students. Given these moderate numbers of new students and the recent increased tax revenue for school construction, it is anticipated that school impacts will be manageable.

### **Public Facilities/Infrastructure**

The project site is located in an area of existing infrastructure. All municipal services (i.e. water, sewer, storm drain, etc.) are either in place or can easily be extended (at the developer's expense) to serve Falcon Ridge North. Power, natural gas, cable television, and high-speed internet service all exist at or adjacent to the project site. Another noteworthy point is that the proposed clustering of units (through a common open space subdivision) will result in resource conservation, reduction in water use, etc. All of the applicable infrastructure is analyzed with the preliminary engineering plans and reports included with this report and compliance is demonstrated.

Preliminary utility plans are included with the engineering plans located in the map pocket of this report.

### **Public Services**

The property is within an acceptable response time of the Truckee Meadows Fire Protection District. The closest Truckee Meadows fire station (Station 45) is located roughly 2.75 miles away (driving distance) and is therefore able to provide adequate service to the site. The Washoe County Sheriff's Office has existing patrols within the project area.

### **Grading**

The site has been previously graded with prior permits. It is currently in an unfinished state with dirt storage piles from ongoing construction of Falcon Ridge. Continuing the buildout of the Falcon Ridge Specific Plan area is the best method to ensure the site is finished with engineered drainage and road access. Grading associated with this Tentative Map was approved as part of previous entitlements, as exhibited by the retaining walls that are already in place on the site. Completing this Tentative Map will reduce visual impacts to the area by removing existing dirt piles and finalizing drainage facilities.

### **Planning Policy Analysis**

The proposed request conforms to the goals and policies of the Sun Valley Area Plan and the Falcon Ridge Specific Plan. Each of these planning documents is addressed below:

#### **Sun Valley Area Plan**

The Sun Valley Area Plan is an element of the Washoe County Master Plan that establishes the overall theme and vision of the community over the next 20 years. Last updated in 2010, there has been very little change within the plan area in the last few years. However, as the region's economy continues to recover, there is now opportunity to implement change within the plan area, consistent with the goals and policies of the Area Plan.

The Introduction section of the Area Plan states that the vision of the plan is to *"Manage growth and its*

---

## FALCON RIDGE NORTH TENTATIVE MAP

*associated impacts in Sun Valley, focusing on preserving the surrounding public lands and upgrading the quality of the built environment while respecting private property rights.”*

This Tentative Map request is entirely consistent with this vision. It manages growth by building out an already planned and approved Specific Plan rather than extending development onto outlying land. The project also includes open space and quality architecture and design.

The Area Plan also establishes an overall Character Statement. The project contributes in multiple ways to furthering the goals of the Character Statement. Specifically, the character statement encourages:

- a mix of housing types
- denser development on the north side of El Rancho Drive
- provision of open space

The proposed project is in direct conformance with these goals. The project site is also within the suburban character management area, an area suitable for development of this type. The suburban character area allows for a maximum of 21 units per acre, well above what is proposed with this project.

### **Falcon Ridge Specific Plan**

The site is subject to the standards contained within the Falcon Ridge Specific Plan. This plan was approved by Washoe County and describes allowable development on the subject parcel and the adjacent area to the south. Per the Plan, the purpose is *“is to provide for a high quality multi-family and attached single family residential project that respects the natural site features through careful placement of homes, preservation of open space, and hillside sensitive grading techniques.”*

The project conforms to this purpose through both the proposed use (attached single family) and the design that preserves open space and minimizes grading.

The Specific Plan includes goals such as *“Guarantee compatibility with adjacent existing developments by utilizing landscaped buffer areas, building height restrictions, curtailment of light pollution, and a maximum density of 269 dwelling units.”*

The proposed project includes landscaped buffer areas, particularly on the western edge where the project is adjacent to existing multi family development. The project conforms to the 35’ height limit, lighting controls, and density restrictions.

The Specific Plan devotes considerable attention to grading practices. It states: *The grading considerations defined in Falcon Ridge Specific Plan will grade as little as possible and will follow the contours of the earth reshaping as needed. Moreover, the entire property has already been graded with the last approved development and the new design will take advantage of the existing grading that has already occurred. Any new grading will follow these goals which include: 1. Minimize disruption to natural topography. 2. Utilization of natural contours and slopes 3. Complement the natural characteristics of the landscape. 4.*

## FALCON RIDGE NORTH TENTATIVE MAP

---

*Limit grading in the drainage way to the design of the boxed culvert. 5. Limit fill in the drainage way to the design of the boxed culvert. 6. Use of rockery walls and benching. 7. Preserve natural rock outcroppings. 8. Use erosion control by slope stabilization runoff controls, collection features and Best Management Practices (BMP).*

The proposed project advances all of these grading goals. The project minimizes grading disruption by avoiding the steepest site sections. The project does not propose to grade in the drainageway except for the required box culvert at the road crossing. The site already includes rockery walls and benching and there are no rock outcroppings. The project will utilize BMPs.

Specific Standards:

**Parking:** Every townhome is required to have four spaces, two from a garage and two in front of the residence. The project provides this.

**Building Height:** Falcon Ridge is limited to 35' building height. The project conforms to this.

**Air Quality:** the project is required to maintain dust control during construction and to prohibit wood burning stoves as per Washoe County Code. The project will conform to these standards.

### Tentative Map Findings

Section 110.608.20 of the Washoe County Development Code establishes legal findings that must be made by the Planning Commission or Board of County Commissioners in order to approve a Tentative Map request. These findings are listed below and are addressed in **bold face** type.

- (a) Environmental and Health Laws. Environmental and health laws and regulations concerning water and air pollution, the disposal of solid waste, facilities to supply water, community or public sewage disposal and, where applicable, individual systems for sewage disposal;

**Falcon Ridge North will be served by municipal water and sewer service, ensuring full compliance with this finding. Additionally, solid waste disposal service will be provided through Waste Management which currently operates routes in the surrounding area.**

**The site is adjacent to existing development and is close to transportation and utility infrastructure. There are no obstacles to providing service to the site.**

- (b) Availability of Water. The availability of water which meets applicable health standards as well as requirements for water rights, quality or will-serve commitments;

**The project site is effectively within the greater Reno/Sparks urban area. Water and all other services are available on adjacent properties, including the previously constructed portion of Falcon Ridge. Water**

## FALCON RIDGE NORTH TENTATIVE MAP

---

rights will be dedicated to TMWA to serve the project, ensuring full compliance with this finding. Water rights can be purchased directly from TMWA or on the open market (with full TMWA acceptance). The developer is familiar with this process and has completed it for the adjacent Falcon Ridge construction.

(c) Utilities. The availability and accessibility of utilities;

The project will be served by all municipal utilities, infrastructure, and services as detailed within this report and on the attached engineering plans. As noted, all services are in place on adjacent properties and can easily be extended to this parcel.

(d) Public Services. The availability and accessibility of public services such as schools, police and fire protection, transportation, recreation and parks;

The project is within the Reno/Sparks urban area. Adjacent properties already receive local services. This site does not represent an extension of service areas for providers.

The closest Truckee Meadows fire station (Station 45) is located roughly 2.75 miles away (driving distance) and is therefore able to provide adequate service to the site. The site is already served by sheriff patrols. Schools serving the project are detailed earlier in this report. Given the modest size of the project, student generation is low and area schools can provide service, particularly given the recent school tax approval that is currently allowing for increased school construction.

(e) Plan Consistency. General conformance with the Development Code and Master Plan;

The project is in direct conformance with the Urban Residential Master Plan designation and Low Density Urban zoning. No changes to these designations are required for this project.

The project conforms to the zoning density and to the design standards of the existing Falcon Ridge Specific Plan. Additionally, the project matches the existing Falcon Ridge development to the south.

(f) Impact on Existing Streets. The effect of the proposed subdivision on existing public streets and the need for new streets or highways to serve the subdivision;

Traffic impacts were thoroughly analyzed with the approval of the Falcon Ridge Specific Plan. This project is following through on the previous approvals associated with the site. Therefore, area roads have already been reviewed and deemed sufficient to serve this project. No new driveways or public road sections are required for this project.

In general, this Tentative Map is modestly sized and does not meet the threshold for a traffic study. Note however that traffic improvements from the Falcon Ridge project are continuing in the area, including a new traffic light scheduled to be installed at the main project entrance on El Rancho Drive. This light will improve safety for area, both for pedestrians and for drivers.

---

## FALCON RIDGE NORTH TENTATIVE MAP

(g) Physical Characteristics. Physical characteristics of the land such as flood plain, slope and soil;

The site is well suited for the type and intensity of development proposed. The site contains no slope or soil conditions that would preclude development nor does it contain any significant wildlife habitats, etc. The site has been previously graded in preparation for this project. This previous grading required engineering review and evaluation, during which the site was found to be suitable for development.

The site is primarily *FEMA Flood Zone X Area of Minimal Flood Hazard*. The site has been subject to grading in the past and includes a drainageway on the south side of the project site that is a combination of natural and engineered topography. This drainageway will be maintained with this project. Box culverts installed as part of this project will be sized to accommodate storm flows. The existing retaining walls on the project site were set at elevations that are clear of the drainageway, based on previous site analysis.

Additional engineering review and documentation accompanies this application.

(h) Agency Review. The recommendations and comments of the entities reviewing the tentative map; and

Copies of this report and the included plans will be circulated to all applicable reviewing agencies for review and comment. Specific requirements and relevant comments can be included as conditions tied to this request and implemented with final map(s).

(i) Impact on Existing Drainage System. The effect of the proposed subdivision on the existing natural and man-made drainage system.

The project will provide for onsite detention to ensure that no additional flows over what currently exist will occur from the site. A detailed hydrology study is also included in the appendices of this report demonstrating compliance with all applicable Washoe County requirements related to drainage.

# APPENDIX

## Washoe County Development Application

Your entire application is a public record. If you have a concern about releasing personal information, please contact Planning and Building staff at 775.328.6100.

|   |                 |  |                 |
|---|-----------------|--|-----------------|
| <b>Project Information</b>  |                 | Staff Assigned Case No.: _____             |                 |
| Project Name: <b>Falcon Ridge North</b>   |                 |  |                 |
| Project Description: 52-lot townhome subdivision, with common open space, connected to an existing phase of Falcon Ridge (WAC18-0001)     |                 |  |                 |
| Project Address: 0 Falcon Rock Lane, Washoe County  |                 |  |                 |
| Project Area (acres or square feet): 6.19 acres   |                 |  |                 |
| Project Location (with point of reference to major cross streets <b>AND</b> area locator):<br><b>Falcon Rock Lane off El Rancho Drive</b> |                 |  |                 |
| Assessor's Parcel No.(s):   | Parcel Acreage: | Assessor's Parcel No.(s):                  | Parcel Acreage: |
| 035-721-02  | 6.19            |  |                 |
| Indicate any previous Washoe County approvals associated with this application:<br>Case No.(s).   |                 |  |                 |
| <b>Applicant Information</b> (attach additional sheets if necessary)  |                 |  |                 |
| <b>Property Owner:</b>  |                 | <b>Professional Consultant:</b>            |                 |
| Name: Falcon Ridge by Desert Wind LP  |                 | Name: Rubicon Design Group                 |                 |
| Address: 550 California Avenue  |                 | Address: 1610 Montclair Avenue, Suite B    |                 |
| Reno, NV  | Zip: 89509      | Reno, NV                                   | Zip: 89509      |
| Phone: 775-626-1800   | Fax:            | Phone: 775-527-6710                        | Fax:            |
| Email: Chris Fawcett <cf@desertwindhomes.com>   |                 | Email: dwilson@rubicondesigngroup.com      |                 |
| Cell:   | Other:          | Cell: 775-527-6710                         | Other:          |
| Contact Person: Chris Fawcett   |                 | Contact Person: Derek Wilson               |                 |
| <b>Applicant/Developer:</b>   |                 | <b>Other Persons to be Contacted:</b>      |                 |
| Name: same as owner   |                 | Name: TEC Civil Engineering                |                 |
| Address:  |                 | Address: 9429 Double Diamond Pkwy, Suite A |                 |
|   | Zip:            |  | Zip:            |
| Phone:  | Fax:            | Phone:                                     | Fax:            |
| Email:  |                 | Email: jgilles@tecreno.com                 |                 |
| Cell:   | Other:          | Cell: 775-846-0164                         | Other:          |
| Contact Person:   |                 | Contact Person: Jason Gilles               |                 |
| <b>For Office Use Only</b>  |                 |  |                 |
| Date Received:  | Initial:        | Planning Area:                             |                 |
| County Commission District:   |                 | Master Plan Designation(s):                |                 |
| CAB(s):   |                 | Regulatory Zoning(s):                      |                 |



## Tentative Subdivision Map Application Supplemental Information

(All required information may be separately attached)

1. What is the location (address or distance and direction from nearest intersection)?

Falcon Rock Lane off El Rancho Drive, north side of existing Falcon Ridge development.

2. What is the subdivision name (proposed name must not duplicate the name of any existing subdivision)?

Falcon Ridge North

3. Density and lot design:

|  |                           |
|--|---------------------------|
| a. Acreage of project site                   | 6.19                      |
| b. Total number of lots                      | 52                        |
| c. Dwelling units per acre                   | 8.4                       |
| d. Minimum and maximum area of proposed lots | 960 sf min., 1,477 sf max |
| e. Minimum width of proposed lots            | 20 linear feet            |
| f. Average lot size                          | 1258 sf                   |

4. What utility company or organization will provide services to the development:

|                                 |                              |
|---------------------------------|------------------------------|
| a. Sewer Service                | Washoe County/Sun Valley GID |
| b. Electrical Service           | NV Energy                    |
| c. Telephone Service            | AT&T                         |
| d. LPG or Natural Gas Service   | NV Energy                    |
| e. Solid Waste Disposal Service | Waste Management             |
| f. Cable Television Service     | Charter                      |
| g. Water Service                | TMWA                         |

5. For common open space subdivisions (Article 408), please answer the following:

- a. Acreage of common open space:

4.69 acres

- b. What development constraints are within the development and how many acres are designated slope, wetlands, faults, springs, and/or ridgelines:

The site is previously approved for development. The attached report addresses the site suitability for this project.

- c. Range of lot sizes (include minimum and maximum lot size):

960 sf min., 1,477 sf max

d. Proposed yard setbacks if different from standard:

This project is designed so that the housing lots match the building footprints. This matches previous development in Falcon Ridge.

e. Justification for setback reduction or increase, if requested:

To match existing development within Falcon Ridge.

f. Identify all proposed non-residential uses:

None.

g. Improvements proposed for the common open space:

The open space is generally not suited for development but the overall project will allow access to area open space and trails.

h. Describe or show on the tentative map any public or private trail systems within common open space of the development:

The site is too small to provide significant amenities but the design allows for access to area public land.

i. Describe the connectivity of the proposed trail system with existing trails or open space adjacent to or near the property:

Public open space can be accessed at the northeast project corner.

j. If there are ridgelines on the property, how are they protected from development?

There are no ridgelines.

k. Will fencing be allowed on lot lines or restricted? If so, how?

Fencing will be allowed in backyards.

l. Identify the party responsible for maintenance of the common open space:

Falcon Ridge includes an HOA to maintain open space.

6. Is the project adjacent to public lands or impacted by "Presumed Public Roads" as shown on the adopted April 27, 1999 Presumed Public Roads (see Washoe County Engineering website at <http://www.washoecounty.us/pubworks/engineering.htm>). If so, how is access to those features provided?

The project is adjacent to public land but there are no presumed public roads. Nearby access to public land is available from El Rancho Drive.

7. Is the parcel within the Truckee Meadows Service Area?

Yes  No

8. Is the parcel within the Cooperative Planning Area as defined by the Regional Plan?

Yes     No    If yes, within what city?

9. Has an archeological survey been reviewed and approved by SHPO on the property? If yes, what were the findings?

There is no development on the property warranting SHPO review.

10. Indicate the type and quantity of water rights the application has or proposes to have available:

|                    |     |                    |     |
|--------------------|-----|--------------------|-----|
| a. Permit #        | n/a | acre-feet per year | n/a |
| b. Certificate #   | n/a | acre-feet per year | n/a |
| c. Surface Claim # | n/a | acre-feet per year | n/a |
| d. Other #         | n/a | acre-feet per year | n/a |

a. Title of those rights (as filed with the State Engineer in the Division of Water Resources of the Department of Conservation and Natural Resources):

The project plans to purchase 8.25af of water from TMWA

11. Describe the aspects of the tentative subdivision that contribute to energy conservation:

The project is composed of moderately sized houses using modern insulation, appliances, and light fixtures.

12. Is the subject property in an area identified by Planning and Building as potentially containing rare or endangered plants and/or animals, critical breeding habitat, migration routes or winter range? If so, please list the species and describe what mitigation measures will be taken to prevent adverse impacts to the species:

No.

13. If private roads are proposed, will the community be gated? If so, is a public trail system easement provided through the subdivision?

The project includes private road and a gate. This phase of the project will conform to the development pattern approved with previous phases.

14. Are there any applicable policies of the adopted area plan in which the project is located that require compliance? If so, which policies and how does the project comply?

The project complies with the Sun Valley Area Plan and the Falcon Ridge Specific Plan, as detailed in the attached report.

15. Are there any applicable area plan modifiers in the Development Code in which the project is located that require compliance? If so, which modifiers and how does the project comply?

Development of the site is controlled by the Falcon Ridge Specific Plan.

16. Will the project be completed in one phase or is phasing planned? If so, please provide that phasing plan:

The project is proposing to be developed in a single phase.

17. Is the project subject to Article 424, Hillside Development? If yes, please address all requirements of the Hillside Ordinance in a separate set of attachments and maps.

|                              |  |   |
|------------------------------|--|---|
| <input type="checkbox"/> Yes | <input checked="" type="checkbox"/> No | If yes, include a separate set of attachments and maps. |
|------------------------------|--|---|

18. Is the project subject to Article 418, Significant Hydrologic Resources? If yes, please address Special Review Considerations within Section 110.418.30 in a separate attachment.

|                              |  |                                       |
|------------------------------|--|---------------------------------------|
| <input type="checkbox"/> Yes | <input checked="" type="checkbox"/> No | If yes, include separate attachments. |
|------------------------------|--|---------------------------------------|

### Grading

Please complete the following additional questions if the project anticipates grading that involves: (1) Disturbed area exceeding twenty-five thousand (25,000) square feet not covered by streets, buildings and landscaping; (2) More than one thousand (1,000) cubic yards of earth to be imported and placed as fill in a special flood hazard area; (3) More than five thousand (5,000) cubic yards of earth to be imported and placed as fill; (4) More than one thousand (1,000) cubic yards to be excavated, whether or not the earth will be exported from the property; or (5) If a permanent earthen structure will be established over four and one-half (4.5) feet high:

19. How many cubic yards of material are you proposing to excavate on site?

|                    |
|--------------------|
| 42,692 cubic yards |
|--------------------|

20. How many cubic yards of material are you exporting or importing? If exporting of material is anticipated, where will the material be sent? If the disposal site is within unincorporated Washoe County, what measures will be taken for erosion control and revegetation at the site? If none, how are you balancing the work on-site?

|  |
|--|
| Material balances on site. This balance is created by installing larger detention ponds. |
|--|

21. Can the disturbed area be seen from off-site? If yes, from which directions, and which properties or roadways? What measures will be taken to mitigate their impacts?

|   |
|---|
| The disturbed area can be seen from the unoccupied eastern side property. Completing the site will be a visual improvement. |
|---|

22. What is the slope (Horizontal/Vertical) of the cut and fill areas proposed to be? What methods will be used to prevent erosion until the revegetation is established?

|   |
|---|
| Max slope will be 3:1 and will be stabilized with rip rap lining. |
|---|

23. Are you planning any berms and, if so, how tall is the berm at its highest? How will it be stabilized and/or revegetated?

|     |
|-----|
| No. |
|-----|

24. Are retaining walls going to be required? If so, how high will the walls be, will there be multiple walls with intervening terracing, and what is the wall construction (i.e. rockery, concrete, timber, manufactured block)? How will the visual impacts be mitigated?

|  |
|--|
| Yes, 8' tall maximum wall height. Some landscape retaining walls will be rockery. Wall construction type will be determined with final design. |
|--|

25. Will the grading proposed require removal of any trees? If so, what species, how many, and of what size?

No tree removal.

26. What type of revegetation seed mix are you planning to use and how many pounds per acre do you intend to broadcast? Will you use mulch and, if so, what type?

Reveg. seed mix will match landscape plan recommendations.

27. How are you providing temporary irrigation to the disturbed area?

Irrigation will be provided.

28. Have you reviewed the revegetation plan with the Washoe Storey Conservation District? If yes, have you incorporated their suggestions?

Revegetation plan will follow standard local practices and requirements.

Property Owner Affidavit

Applicant Name: Falcon by Desert Wind

The receipt of this application at the time of submittal does not guarantee the application complies with all requirements of the Washoe County Development Code, the Washoe County Master Plan or the applicable area plan, the applicable regulatory zoning, or that the application is deemed complete and will be processed.

STATE OF NEVADA )  
COUNTY OF WASHOE )

I, Chris Fawcett  
(please print name)

being duly sworn, depose and say that I am the owner\* of the property or properties involved in this application as listed below and that the foregoing statements and answers herein contained and the information herewith submitted are in all respects complete, true, and correct to the best of my knowledge and belief. I understand that no assurance or guarantee can be given by members of Planning and Building.

(A separate Affidavit must be provided by each property owner named in the title report.)

Assessor Parcel Number(s): 035-721-01, 035-721-02

Printed Name Chris Fawcett

Signed [Signature]

Address 550 California Ave  
Reno, NV 89509

Subscribed and sworn to before me this 14 day of August, 2019.

Melanie Cook  
Notary Public in and for said county and state

My commission expires: 7/16/2022

(Notary Stamp)

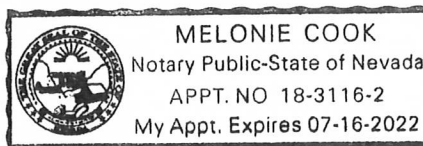

\*Owner refers to the following: (Please mark appropriate box.)

- Owner
- Corporate Officer/Partner (Provide copy of record document indicating authority to sign.)
- Power of Attorney (Provide copy of Power of Attorney.)
- Owner Agent (Provide notarized letter from property owner giving legal authority to agent.)
- Property Agent (Provide copy of record document indicating authority to sign.)
- Letter from Government Agency with Stewardship

Bill Detail

| Washoe County Parcel Information  |        |   |
|---|--------|---|
| Parcel ID   | Status | Last Update   |
| 03572102  | Active | 8/15/2019 2:07:55 AM                                  |
| <b>Current Owner:</b><br>FALCON RIDGE BY DESERT WIND LP<br>550 CALIFORNIA AVE<br>RENO, NV 89509 |        | <b>SITUS:</b><br>0 FALCON ROCK LN<br>WASHOE COUNTY NV |
| <b>Taxing District</b><br>4000  |        | <b>Geo CD:</b>  |
| Legal Description   |        |   |
| Township 20 Section 30 Lot 2 Block Range 20 SubdivisionName FALCON RIDGE                        |        |   |

| Installments      |           |          |                   |               |               |                   |
|-------------------|-----------|----------|-------------------|---------------|---------------|-------------------|
| Period            | Due Date  | Tax Year | Tax               | Penalty/Fee   | Interest      | Total Due         |
| INST 1            | 8/19/2019 | 2019     | \$844.58          | \$0.00        | \$0.00        | \$844.58          |
| INST 2            | 10/7/2019 | 2019     | \$844.56          | \$0.00        | \$0.00        | \$844.56          |
| INST 3            | 1/6/2020  | 2019     | \$844.56          | \$0.00        | \$0.00        | \$844.56          |
| INST 4            | 3/2/2020  | 2019     | \$844.56          | \$0.00        | \$0.00        | \$844.56          |
| <b>Total Due:</b> |           |          | <b>\$3,378.26</b> | <b>\$0.00</b> | <b>\$0.00</b> | <b>\$3,378.26</b> |

| Tax Detail                          |                   |                   |                   |
|-------------------------------------|-------------------|-------------------|-------------------|
|                                     | Gross Tax         | Credit            | Net Tax           |
| State of Nevada                     | \$202.42          | (\$25.18)         | \$177.24          |
| Truckee Meadows Fire Dist           | \$642.98          | (\$79.98)         | \$563.00          |
| Washoe County                       | \$1,657.10        | (\$206.10)        | \$1,451.00        |
| Washoe County Sc                    | \$1,355.62        | (\$168.62)        | \$1,187.00        |
| TRUCKEE MDWS/SUN VALLEY WATER BASIN | \$0.02            | \$0.00            | \$0.02            |
| Total Tax                           | <b>\$3,858.14</b> | <b>(\$479.88)</b> | <b>\$3,378.26</b> |

| Payment History          |
|--------------------------|
| No Payment Records Found |

**Pay By Check**

Please make checks payable to:  
**WASHOE COUNTY TREASURER**

**Mailing Address:**  
P.O. Box 30039  
Reno, NV 89520-3039

**Overnight Address:**  
1001 E. Ninth St., Ste D140  
Reno, NV 89512-2845

**Change of Address**

All requests for a mailing address change must be submitted in writing, including a signature (unless using the online form).

To submit your address change online [click here](#)

Address change requests may also be faxed to: (775) 328-3642

Address change requests may also be mailed to:  
Washoe County Assessor  
1001 E 9th Street  
Reno, NV 89512-2845

The Washoe County Treasurer's Office makes every effort to produce and publish the most current and accurate information possible. No warranties, expressed or implied, are provided for the data herein, its use, or its interpretation. If you have any questions, please contact us at (775) 328-2510 or tax@washoecounty.us



August 2, 2019

Chris Fawcett  
Falcon Ridge by Desert Wind, LP  
550 California Ave  
Reno, NV 89509

**RE: Falcon Ridge North  
Acknowledgement of Water Service  
TMWA Work Order 19-6994**

I have reviewed the plans for the above referenced development (Project) as submitted to the Truckee Meadows Water Authority (TMWA) and have determined that the Project is within TMWA's retail water service area. This letter constitutes an Acknowledgment of Water Service pursuant to NAC 445A.6666, and TMWA hereby acknowledges that TMWA is agreeable to supplying water service to the Project, subject to applicant satisfying certain conditions precedent, including, without limitation, the dedication of water resources, approval of the water supply plan by the local health authority, the execution of a Water Service Agreement, payment of fees, and the construction and dedication of infrastructure in accordance with TMWA's rules and tariffs. This Acknowledgement does not constitute a legal obligation by TMWA to supply water service to the Project, and, is made subject to all applicable TMWA Rules.

Review of conceptual site plans or tentative maps by TMWA does not constitute an application for service, nor implies a commitment by TMWA for planning, design or construction of the water facilities necessary for service. The extent of required off-site and on-site water infrastructure improvements will be determined by TMWA upon receiving a specific development proposal or complete application for service and upon review and approval of a water facilities plan. After submittal of a complete Application for Service, the required facilities, the cost of these facilities, which could be significant, and associated fees will be estimated and will be included as part of the Water Service Agreement for the Project. All fees must be paid to TMWA prior to water being delivered to the Project.

Sincerely,  
Truckee Meadows Water Authority

Brooke Long, P.E.





# FALCON RIDGE NORTH TENTATIVE MAP

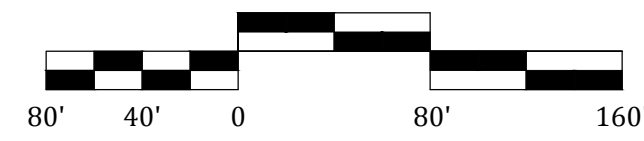

**OWNER**  
 DESERT WIND, LLC  
 550 CALIFORNIA AVE.  
 RENO, NEVADA 89509

**ENGINEER**  
 TEC CIVIL ENGINEERING CONSULTANTS  
 9429 DOUBLE DIAMOND PARKWAY, SUITE A  
 RENO, NEVADA 89521

**SHEET INDEX**

|   |       |                            |
|---|-------|----------------------------|
| 1 | ..... | PRELIMINARY COVER SHEET    |
| 2 | ..... | PRELIMINARY SITE PLAN      |
| 3 | ..... | PRELIMINARY GRADING PLAN   |
| 4 | ..... | PRELIMINARY UTILITY PLAN   |
| 5 | ..... | PRELIMINARY CROSS-SECTIONS |

**LEGEND**

- PROJECT BOUNDARY
- EXISTING LOT LINE
- ⊗ SECTION CORNER
- TIE LINE
- SET 5/8" REBAR w/ CAP PLS 7998
- FOUND 5/8" REBAR w/ CAP PLS 7998 OR OTHERWISE NOTED
- COMMON AREA TO BE DEDICATED

**BOUNDARY LINE TABLE**

| LINE | LENGTH | DIRECTION     |
|------|--------|---------------|
| L1   | 83.07  | N 71°04'49" E |
| L2   | 17.71  | N 35°22'48" E |
| L3   | 74.40  | N 73°54'46" E |
| L4   | 39.96  | N 31°43'07" E |
| L5   | 71.66  | S 40°23'59" W |
| L6   | 67.20  | S 45°18'41" W |
| L7   | 50.14  | S 57°48'25" W |
| L8   | 61.08  | S 80°19'22" W |
| L9   | 49.06  | S 79°23'05" W |
| L10  | 53.64  | N 84°02'10" W |
| L11  | 19.51  | N 62°30'05" W |

**REFERENCES**

- SUBDIVISION TRACT MAP No. 5302, DOCUMENT No. 4873747
- REVERSION TRACT MAP No. 5039, DOCUMENT No. 4244388
- RECORD OF SURVEY MAP No. 3204, DOCUMENT No. 2078934
- SUBDIVISION TRACT MAP No. 4712, DOCUMENT No. 3451625
- PARCEL MAP No. 1555, DOCUMENT No. 891317

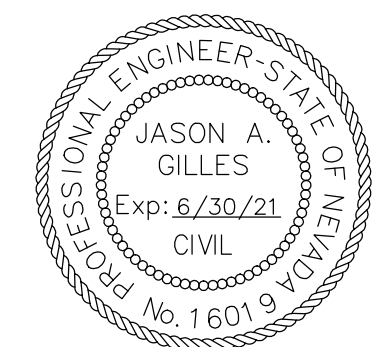

THIS TENTATIVE SUBDIVISION MAP HAS BEEN CREATED AND IS IN COMPLIANCE WITH ALL APPLICABLE PROVISIONS OF THE WASHOE COUNTY DEVELOPMENT CODE:

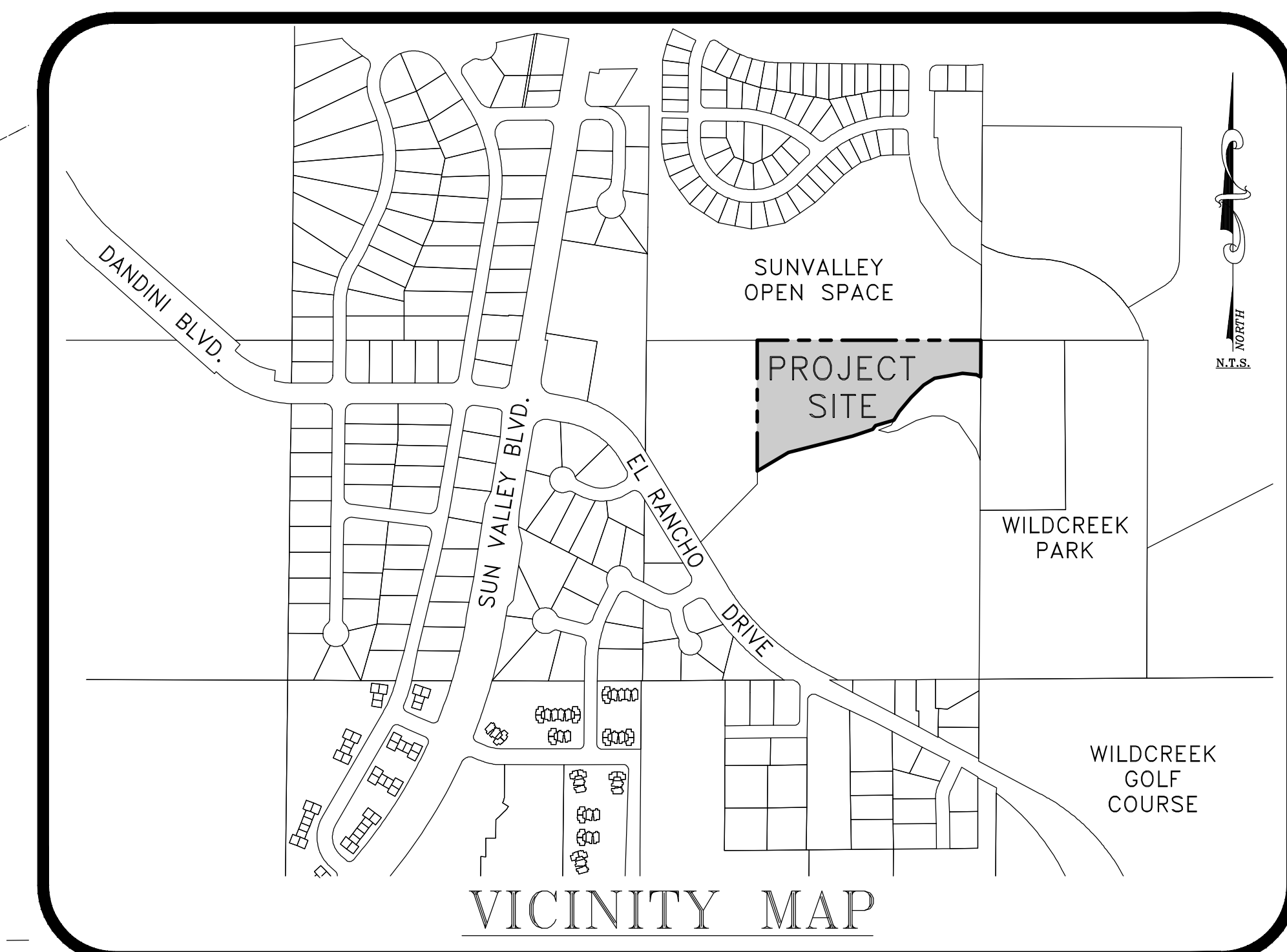

**PRELIMINARY COVER SHEET**



# FALCON RIDGE NORTH TENTATIVE MAP

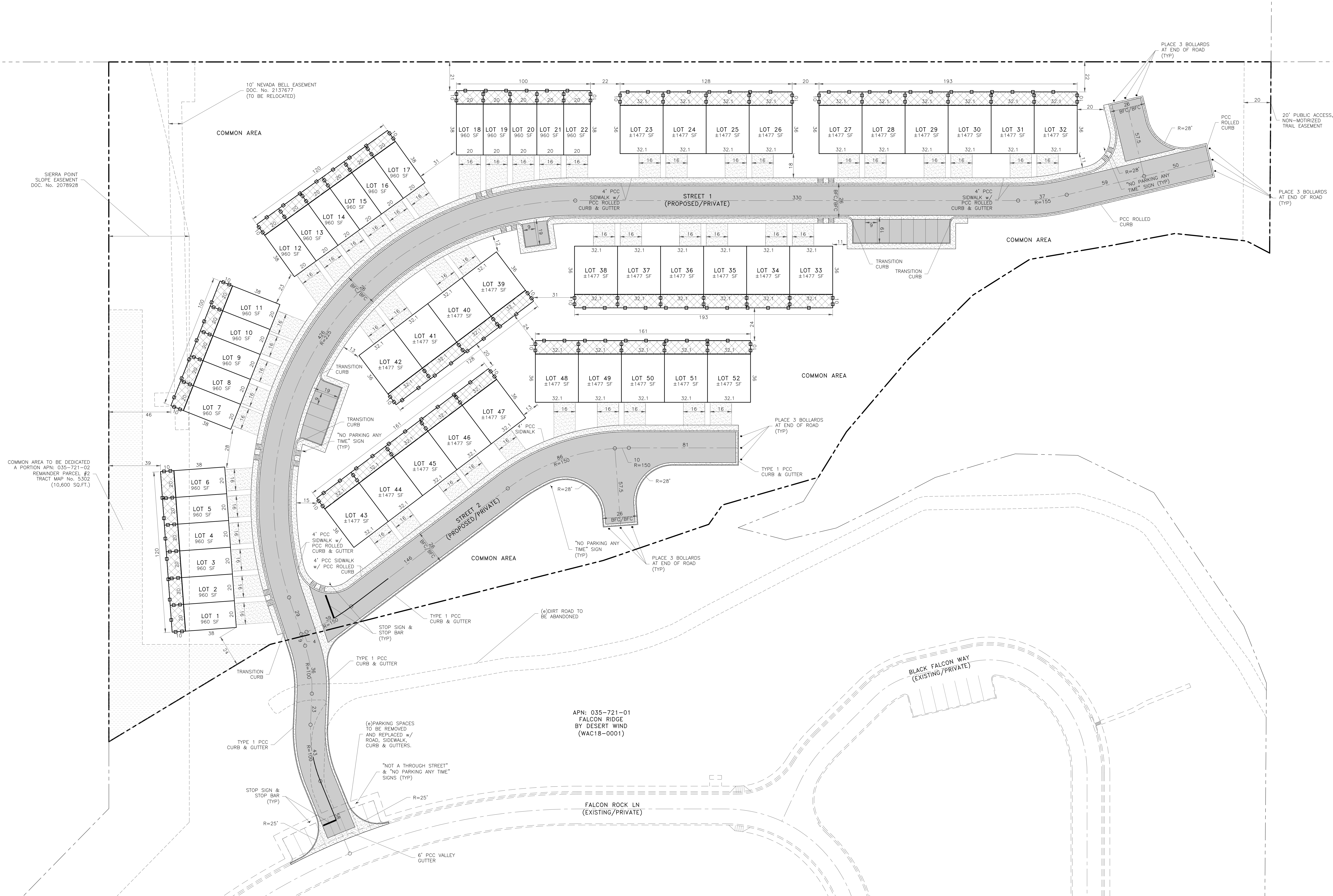

### PROJECT / LAND USE DATA

|                                    |                |
|------------------------------------|----------------|
| TOTAL NUMBER OF LOTS               | 52             |
| TOTAL PROJECT AREA                 | 6.19 ACRES     |
| GROSS RESIDENTIAL DENSITY          | ±322 LOT-ACRES |
| <b>LOT BREAKDOWN</b>               |                |
| SMALLEST LOT SIZE                  | 960 S.F.       |
| LARGEST LOT SIZE                   | 1,477 S.F.     |
| AVERAGE LOT SIZE                   | 871 S.F.       |
| <b>LAND USE BREAKDOWN</b>          |                |
| LOT AREA                           | 1.50 ACRES     |
| PRIVATE STREET AREA (TOTAL)        | 1.01 ACRES     |
| PRIVATE STREET AREA (ON-SITE)      | 0.90 ACRES     |
| PRIVATE STREET AREA (OFF-SITE)     | 0.11 ACRES     |
| COMMON AREA                        | 4.42 ACRES     |
| DEDICATED COMMON AREA              | 0.24 ACRES     |
| CURRENT ZONING                     | LDU            |
| GUEST SPACES PROVIDED              | 15 SPACES      |
| *STREET AREA MEASURED BFC/BFC.     |                |
| *INCLUDES ON-SITE PRIVATE STREETS. |                |
| DOES NOT INCLUDE DEDICATED PARCEL. |                |

### UTILITY DATA

|                           |                                 |
|---------------------------|---------------------------------|
| CABLE                     | CHARTER COMMUNICATIONS          |
| ELECTRIC                  | NV ENERGY                       |
| GAS                       | NV ENERGY                       |
| SANITARY SEWER (ON-SITE)  | WASHOE COUNTY                   |
| SANITARY SEWER (OFF-SITE) | SUN VALLEY GID                  |
| SOLID WASTE               | WASTE MANAGEMENT                |
| TELEPHONE                 | AT&T                            |
| WATER                     | TRUCKEE MEADOWS WATER AUTHORITY |

### NOTES:

1. ALL PROPOSED STREETS WITHIN THE TENTATIVE MAP ARE PRIVATELY OWNED AND MAINTAINED BY THE HOA OR EQUIVALENT.
2. REF. SHEET 5 FOR STREET CROSS-SECTIONS.
3. ALL PROPOSED PRIVATE STREETS TO HAVE PAINTED RED CURBS AND "NO PARKING" SIGNAGE.

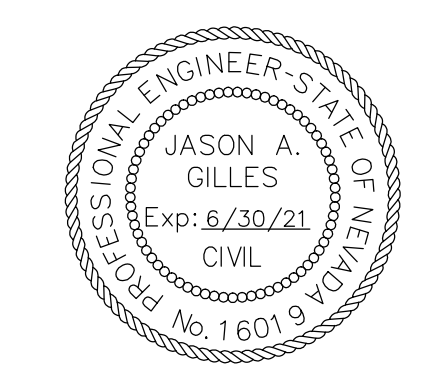

### BASIS OF BEARING

THE NAD-83/94 NEVADA STATE PLANE WEST ZONE (EPOCH 2010) COORDINATE GRID BEARINGS FROM THE TRUCKEE MEADOWS REGIONAL GPS "VRS" NETWORK. GROUND COORDINATES ARE SHOWN AND WERE OBTAINED BY MULTIPLYING THE GRID COORDINATES BY A SCALE FACTOR OF 1.000197939 (R/S 2775, R/S 3396, & R/S 3855). ALL DISTANCES SHOWN ARE GROUND DISTANCES.

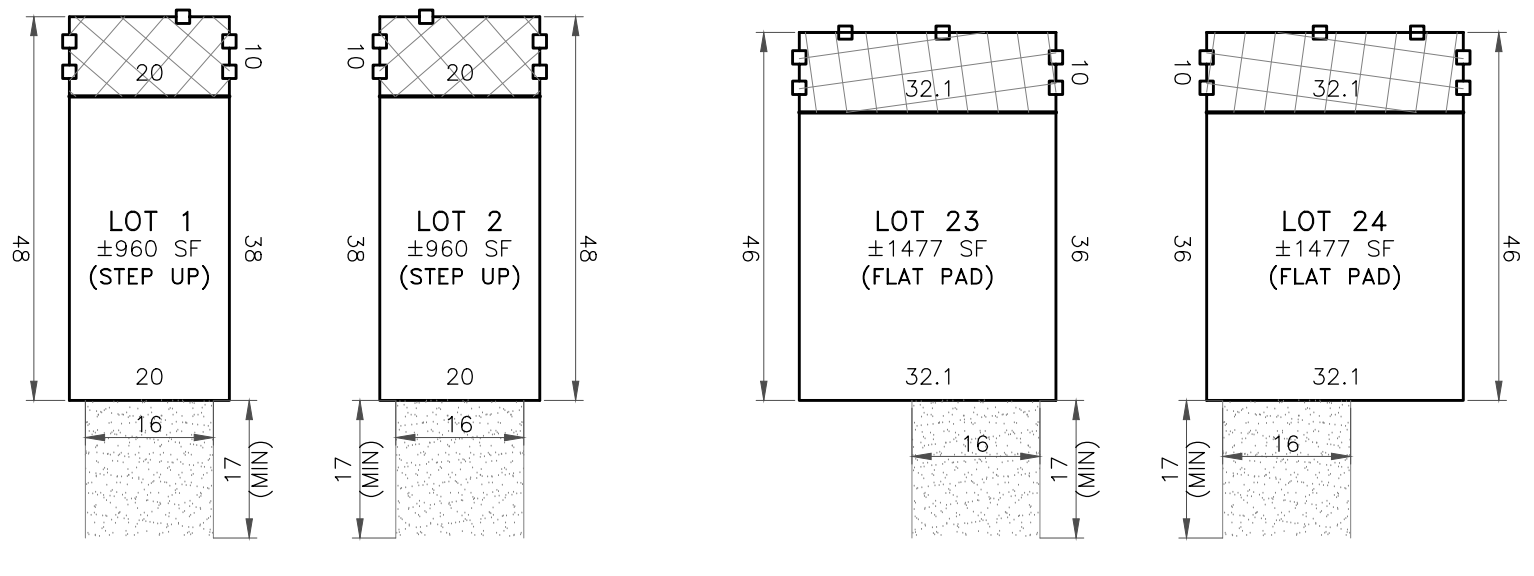

MODELS 1-22  
20' WIDE X 48' DEEP  
±960 SF/UNIT  
(22 LOTS)

MODELS 23-52  
32.1' WIDE X 46' DEEP  
±1477 SF/UNIT  
(30 LOTS)

TYPICAL LOT DIMENSIONS  
N.T.S.

### LEGEND

- PROJECT BOUNDARY
- - - EXISTING LOT LINE
- PROPOSED LOT LINE
- ▨ PROPOSED A.C. PAVEMENT AREA
- ▩ PROPOSED CONCRETE AREA
- ▧ PROPOSED FENCED BACKYARD AREA
- ▤ PEDESTRIAN RAMP
- - - EXISTING EASEMENT
- COMMON AREA TO BE DEDICATED

## PRELIMINARY SITE PLAN



# FALCON RIDGE NORTH TENTATIVE MAP

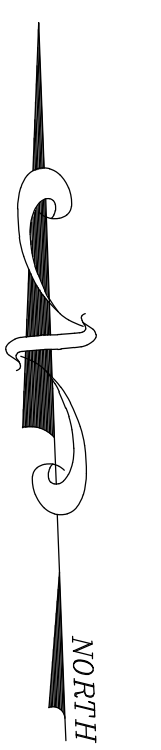

## LEGEND

- PROJECT BOUNDARY
- PROPOSED LOT LINE
- A.C. PAVEMENT AREA
- CONCRETE AREA
- PEDESTRIAN RAMP
- STORM DRAIN w/ DIRECTION (DASHED IF EXISTING)
- CATCH BASIN (HOLLOW IF EXISTING)
- STORM DRAIN MANHOLE (HOLLOW IF EXISTING)
- RETAINING WALL (8' MAX HEIGHT)
- GRADE BREAK
- PROPOSED ELEVATION @ FINISHED GRADE
- PROPOSED ELEVATION @ GRADE BREAK
- PROPOSED ELEVATION @ HIGH POINT
- PROPOSED ELEVATION @ BEGINNING OF VERTICAL CURVE
- PROPOSED ELEVATION @ END OF VERTICAL CURVE
- EXISTING CONTOUR LINE
- PROPOSED CONTOUR LINE
- EXISTING LOT LINE
- LOT 3
- LOT NUMBERS
- FEMA FLOOD PLAN BOUNDARY
- SLOPE INDICATOR
- LIMITS OF GRADING

## EARTHWORK QUANTITIES

TOTAL PROJECT AREA ..... 6.19 ACRES  
 TOTAL DISTURBED AREA ..... 5.28 ACRES  
 \*TOTAL AREA >30% ..... 1.77 ACRES

\*(REF. NOTE 6 ~ THIS SHEET)

CUT = 42,692 Cu.Yds.  
 FILL = 42,692 Cu. Yds.  
 NET = 0 Cu. Yds.

## NOTES:

1. ADD 4500 FEET TO ALL SPOT ELEVATIONS.
2. REF. SHEET 5 FOR CROSS-SECTIONS.
3. ALL 2:1 SLOPES WITHIN DETENTION PONDS TO BE COVERED WITH #8"-12" RIP RAP PER GEOTECHNICAL ENGINEER'S AND/OR LANDSCAPE ARCHITECT'S RECOMMENDATIONS WITH FINAL DESIGN.
4. ALL 3:1 SLOPES TO BE TREATED WITH EITHER DG MULCH, 4" ROCK MULCH OR REVEG SEEDING MIX PER LANDSCAPE ARCHITECT'S RECOMMENDATIONS WITH FINAL DESIGN.
5. PROPER BMP'S TO BE DECIDED UPON WITH FINAL DESIGN.
6. PROJECT SITE HAS BEEN PREVIOUSLY DISTURBED/GRADED. TOTAL AREAS WITH A SLOPE OVER 30% NOT REPRESENTATIVE OF ORIGINAL SITE.

**BASIS OF ELEVATION**  
 BASIS OF ELEVATIONS IS THE RENO DATUM, NAVD 1988

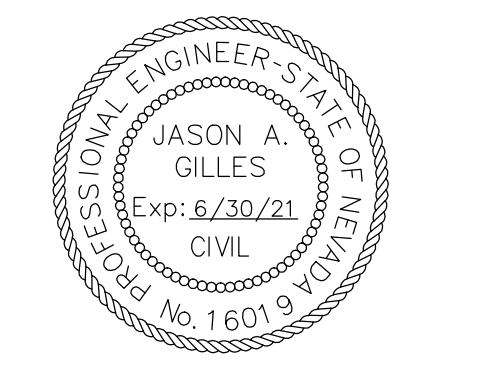

## PRELIMINARY GRADING PLAN

SHEET 3 of 5

SHEET 3 of 5  
 PRELIMINARY GRADING PLAN  
 DATE: 8/15/2019  
 SCALE: 1"=30'  
 JOB #: DESERTWIND.01

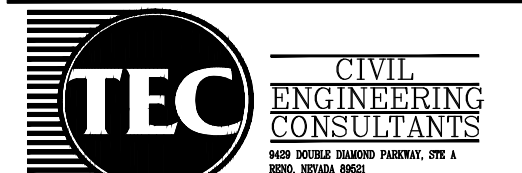

# FALCON RIDGE NORTH TENTATIVE MAP

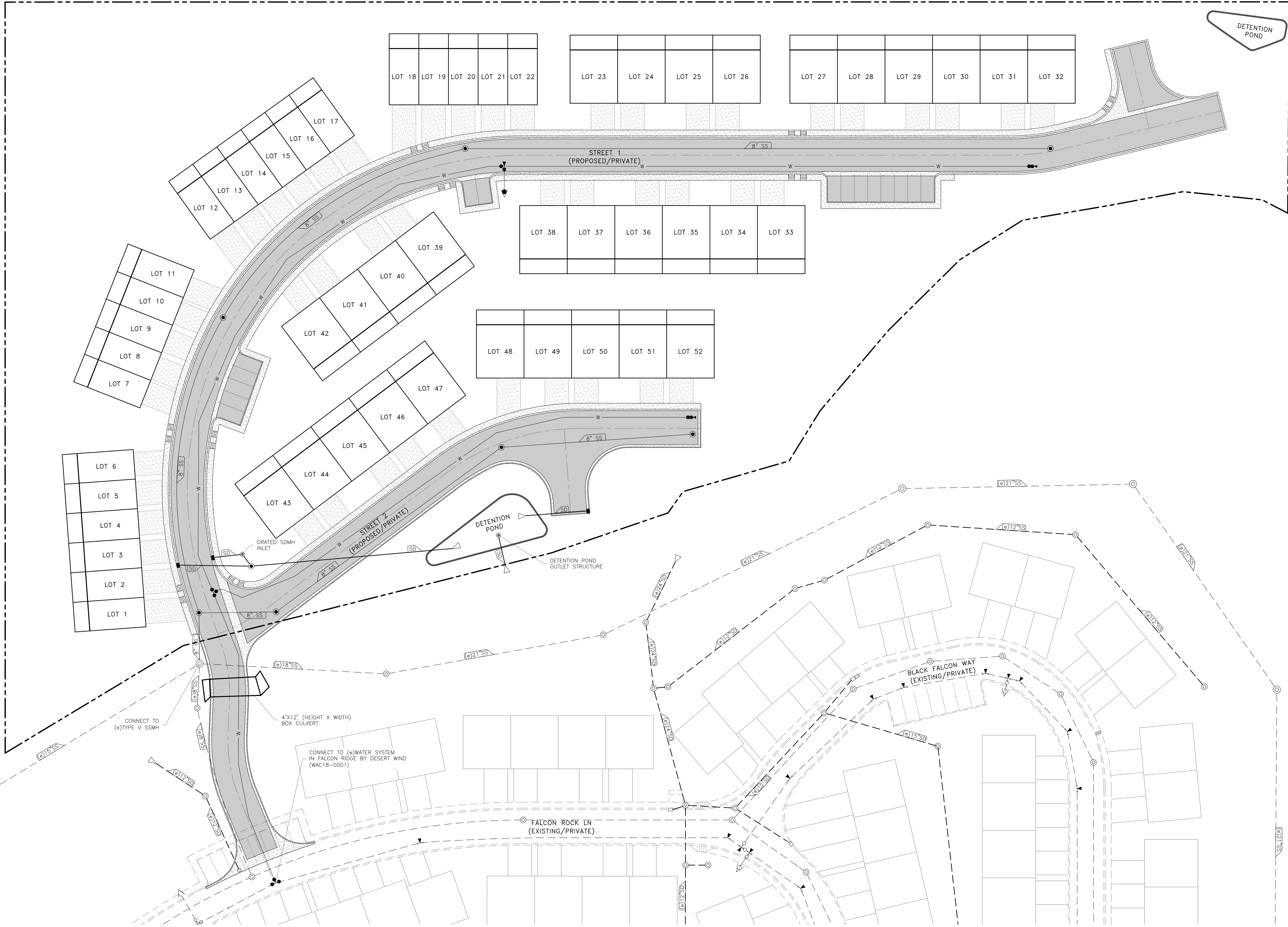

**LEGEND**

- PROJECT BOUNDARY
- - - PROPOSED LOT LINE
- ▨ A.C. PAVEMENT AREA
- ▩ CONCRETE AREA
- ▧ PEDESTRIAN RAMP
- SD STORM DRAIN w/ DIRECTION (DASHED IF EXISTING)
- SS SANITARY SEWER MAIN w/ DIAMETER & DIRECTION (DASHED IF EXISTING)
- W WATER MAIN w/ GAS (DASHED IF EXISTING)
- CATCH BASIN (HOLLOW IF EXISTING)
- MANHOLE (HOLLOW IF EXISTING)
- FIRE HYDRANT (HOLLOW IF EXISTING)

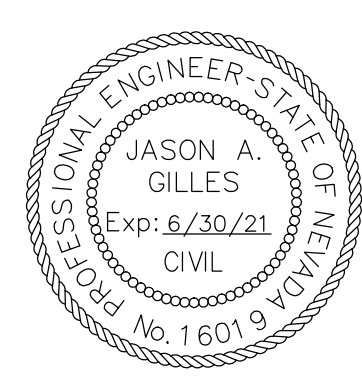

- NOTES:**
1. PROPOSED STORM DRAIN SYSTEM TO BE PUBLICLY OWNED AND MAINTAINED.
  2. PROPOSED GRAVITY SANITARY SEWER SYSTEM TO BE PUBLICLY OWNED AND MAINTAINED.
  3. PROPOSED WATER SYSTEM TO BE OWNED AND MAINTAINED BY THE TRUCKEE MEADOWS WATER AUTHORITY (TMWA).
  4. PROPOSED DETENTION PONDS TO BE PRIVATELY OWNED AND MAINTAINED BY THE HOA OR EQUIVALENT.
  5. DETENTION POND OUTLET STRUCTURE TO BE SIZED WITH FINAL DESIGN.



## PRELIMINARY UTILITY PLAN

# FALCON RIDGE NORTH TENTATIVE MAP

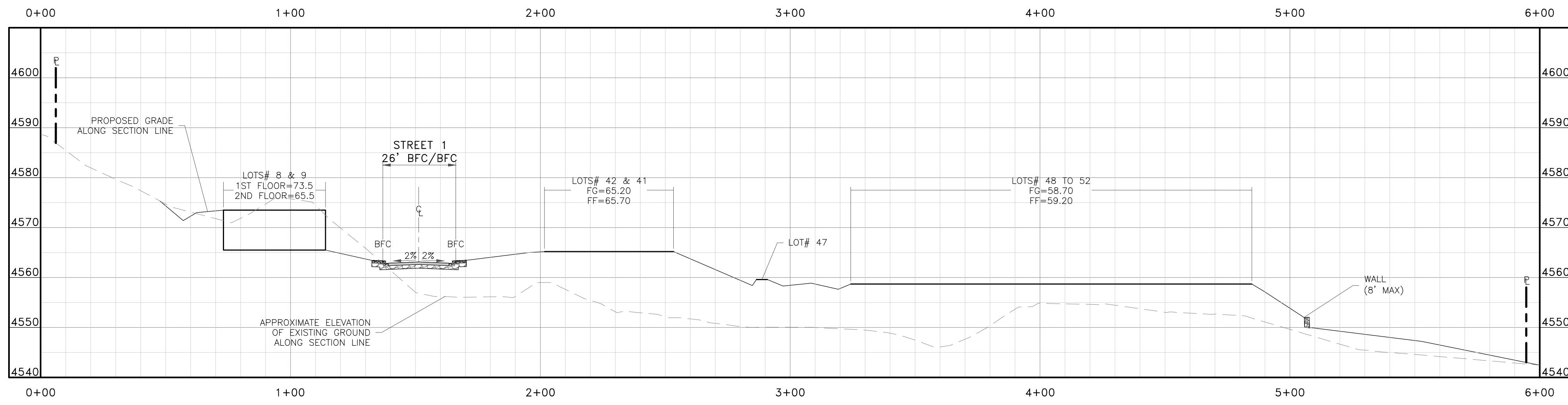
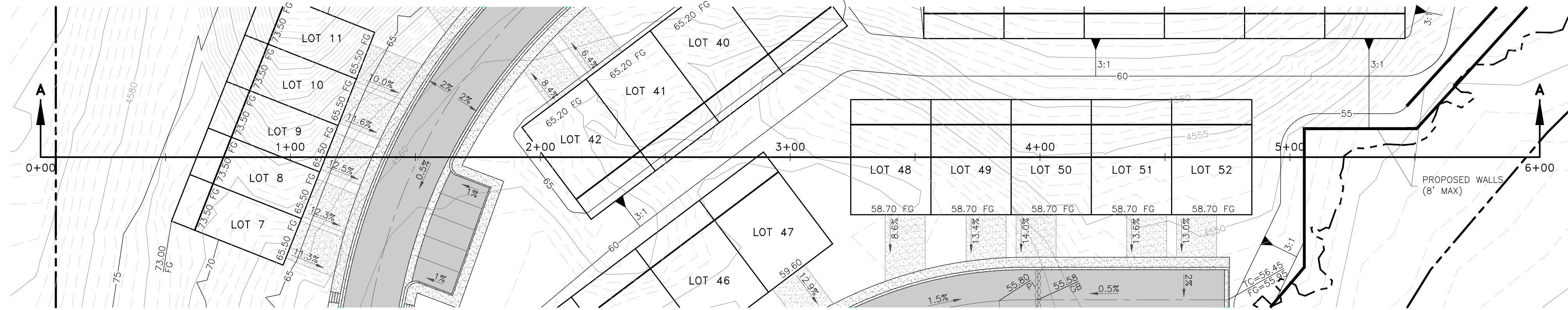

SECTION A-A

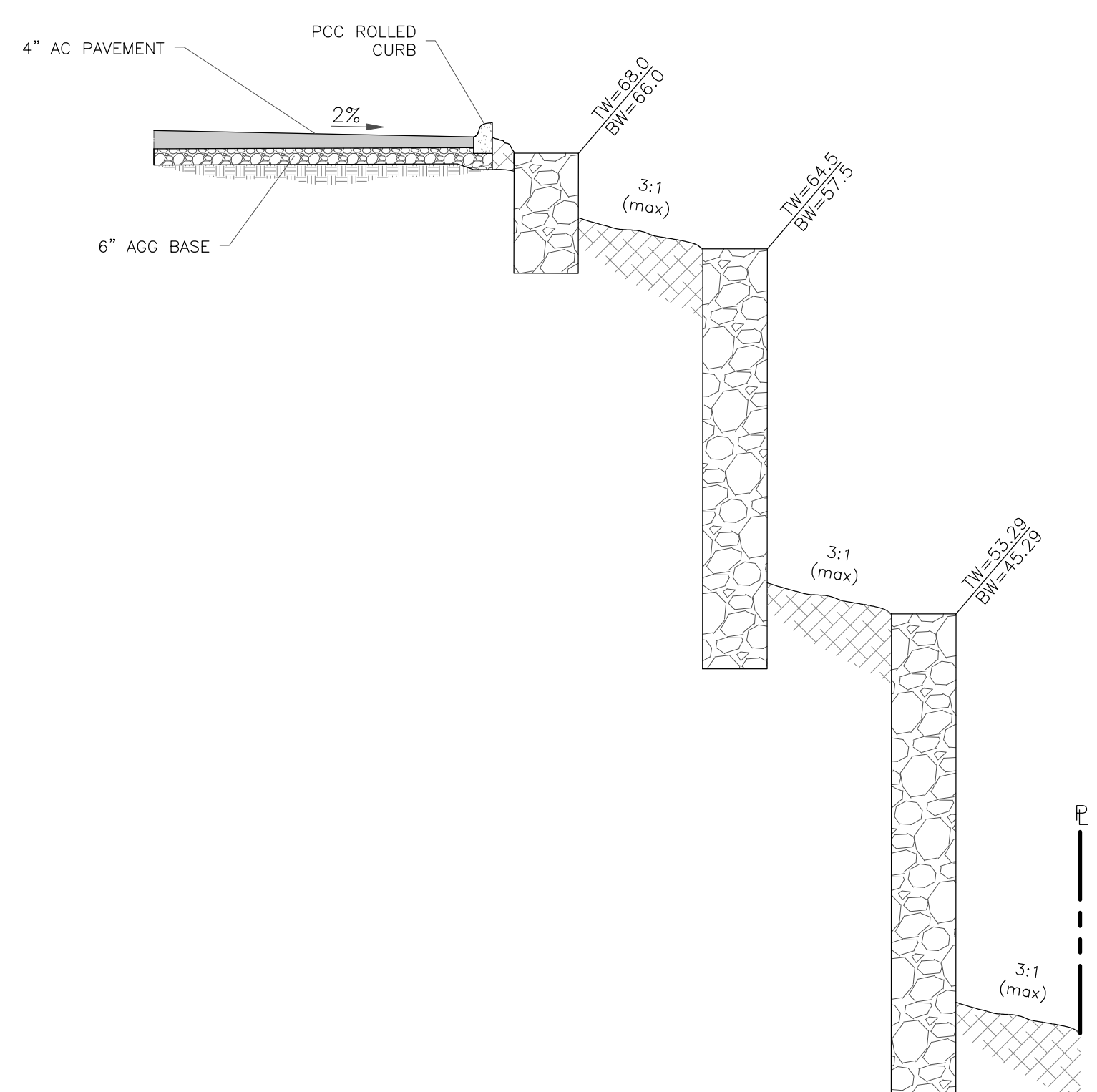
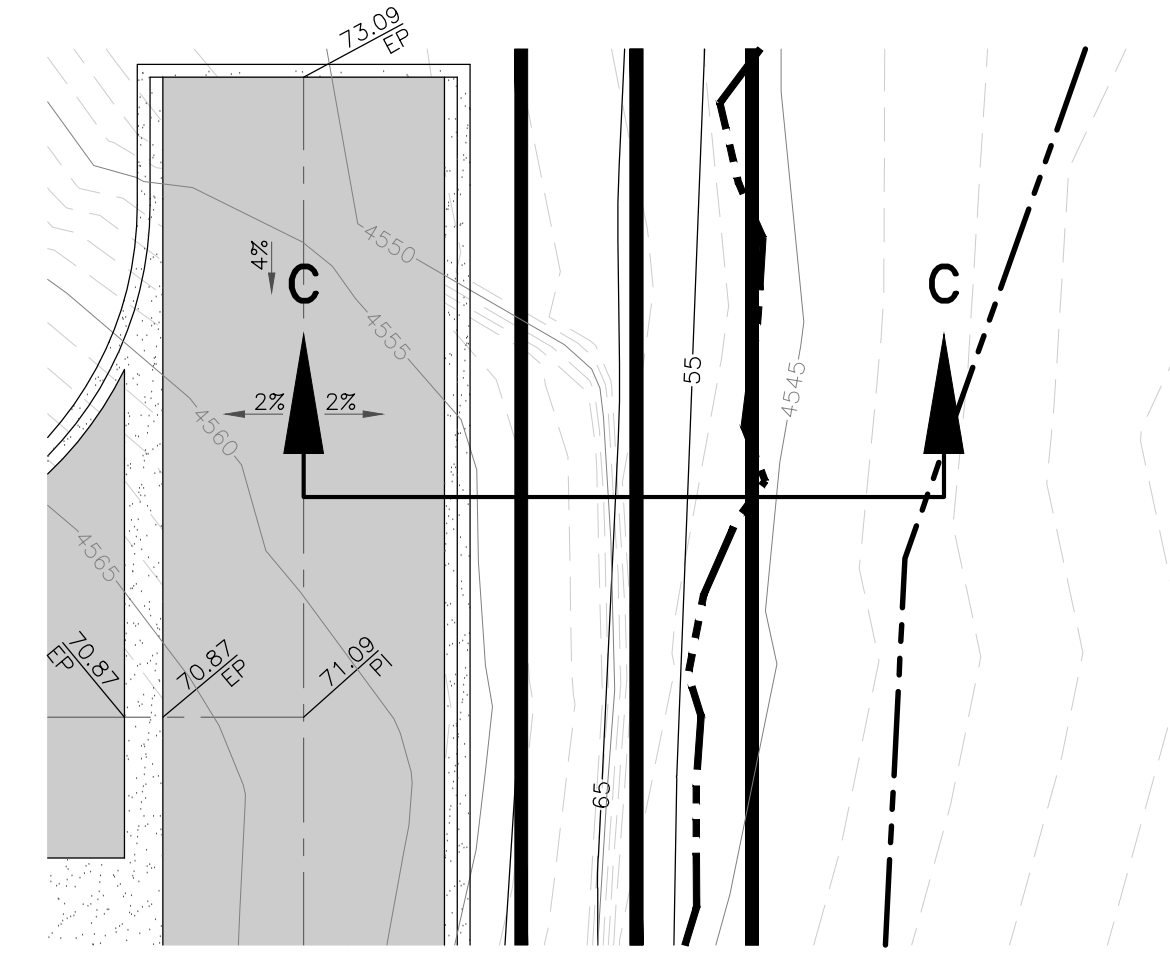

SECTION C-C  
(N.T.S.)

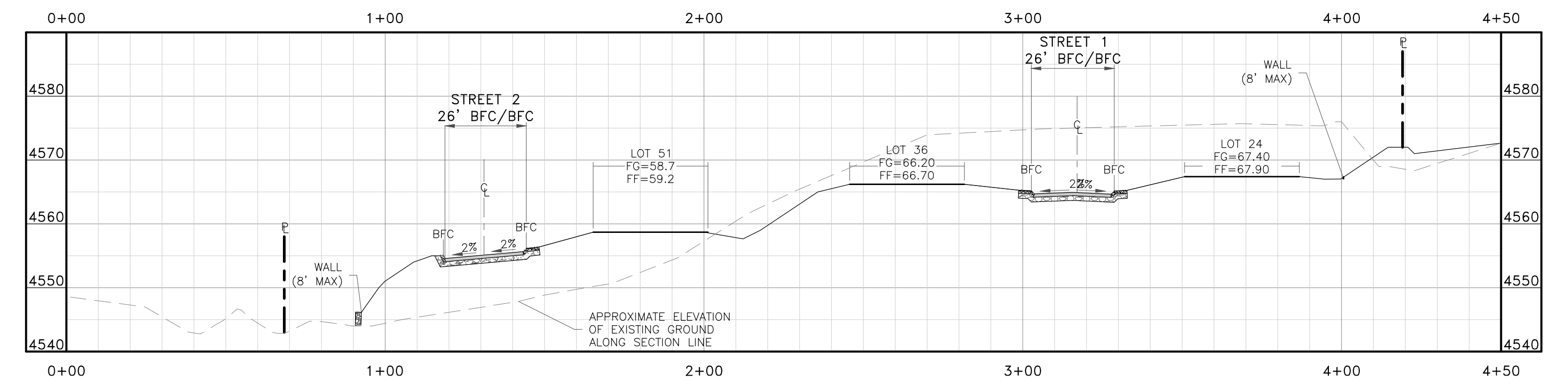
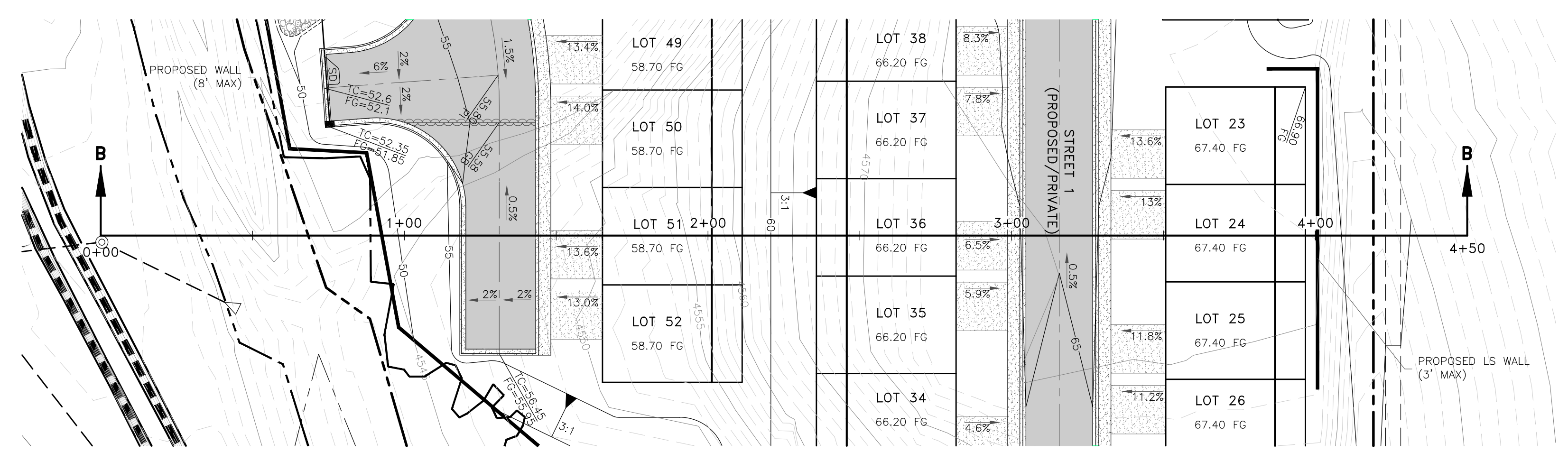
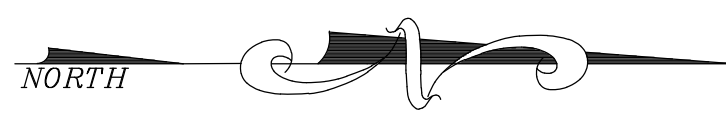

SECTION B-B

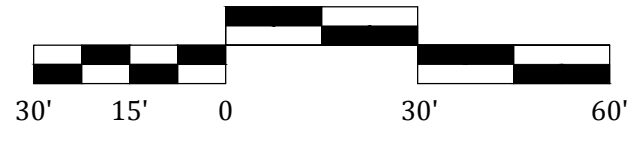

HORIZONTAL SCALE  
1"=30'

VERTICAL SCALE  
1"=15'

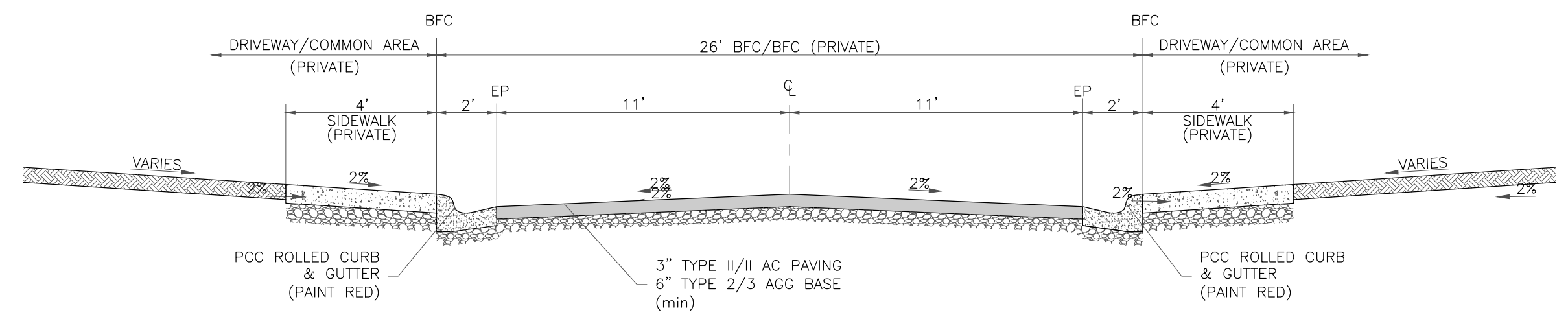

STREET 1 (PRIVATE)  
NO PARKING (N.T.S.)

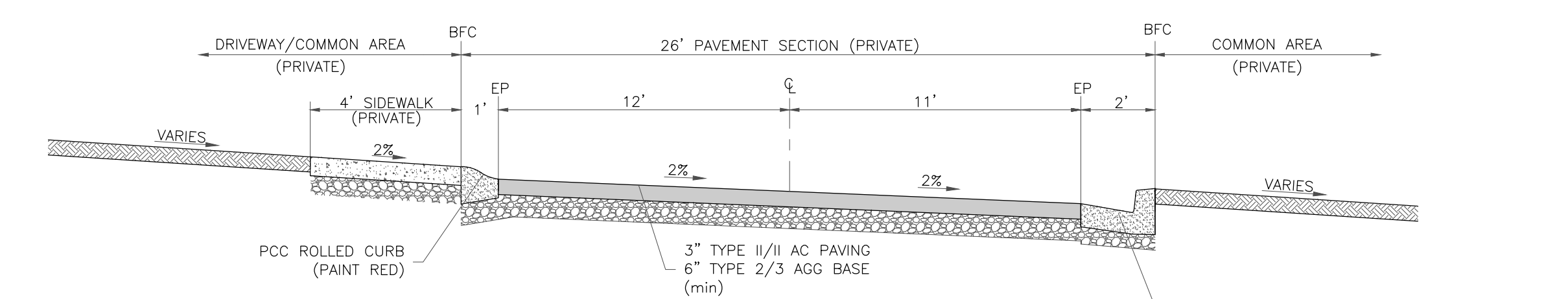

STREET 2 (PRIVATE)  
NO PARKING (N.T.S.)

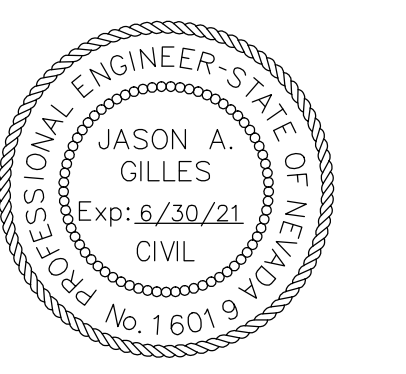

- NOTES:**
1. ADD 4500 FEET TO ALL SPOT ELEVATIONS
  2. REF. GRADING PLAN FOR CROSS-SECTION LOCATIONS.

## PRELIMINARY CROSS-SECTIONS



# FALCON RIDGE NORTH TENTATIVE MAP



| Number | Minimum Slope | Maximum Slope | Area    | % TOTAL AREA | Color  |
|--------|---------------|---------------|---------|--------------|--------|
| 1      | 0%            | 15%           | 129,735 | 48%          | Green  |
| 2      | 15%           | 20%           | 16,695  | 6%           | Yellow |
| 3      | 20%           | 25%           | 22,123  | 8%           | Orange |
| 4      | 25%           | 30%           | 24,250  | 9%           | White  |
| 5      | 30%           | >30%          | 76,892  | 29%*         | Red    |

\* PROJECT SITE HAS BEEN PREVIOUSLY DISTURBED/GRADED. TOTAL AREAS WITH A SLOPE OVER 30% NOT REPRESENTATIVE OF ORIGINAL SITE.





# FALCON RIDGE NORTH TENTATIVE MAP

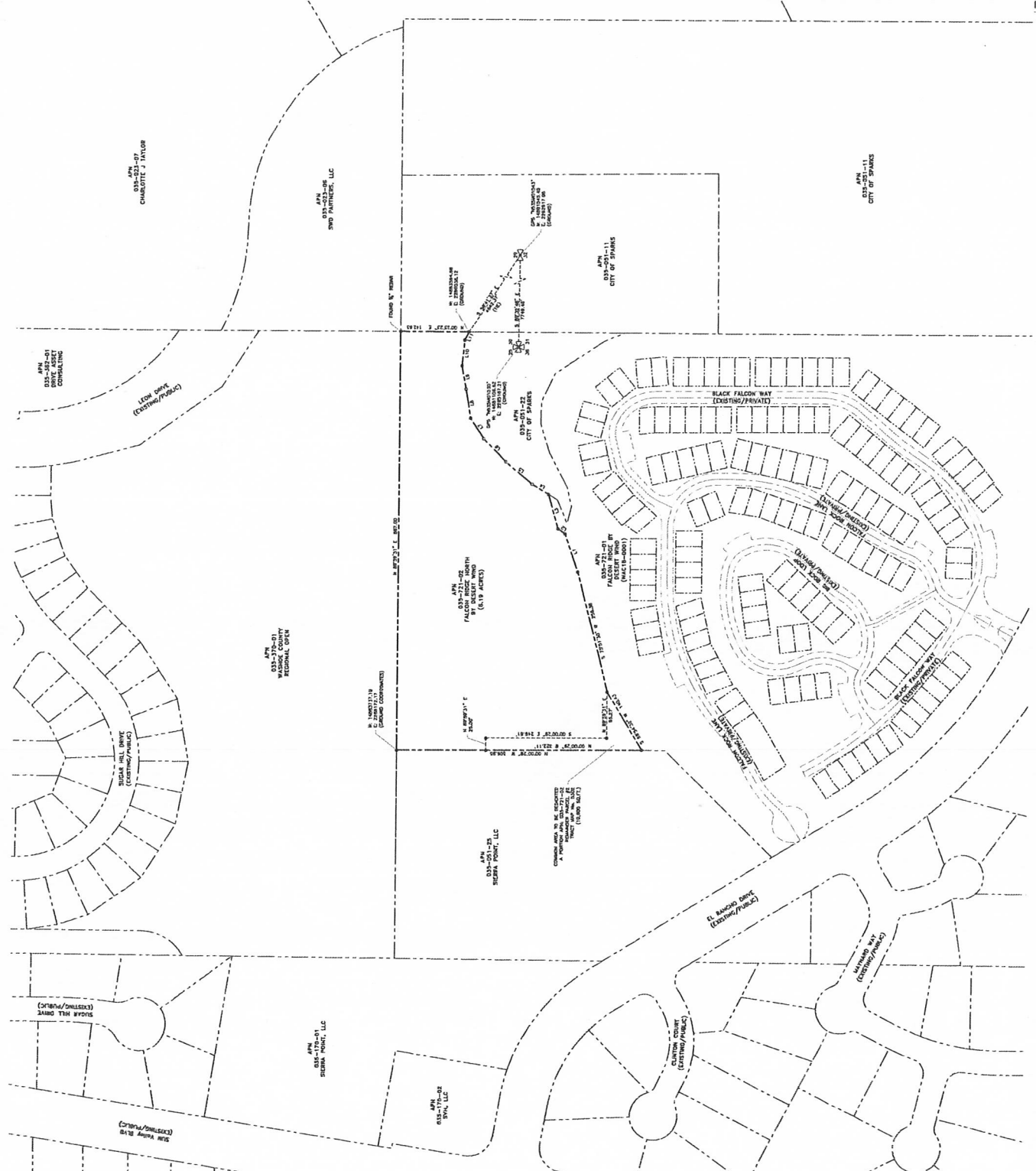

**OWNER**  
SUGAR POINT, LLC  
250 CALIFORNIA, LLC  
DENVER, NEVADA 89589

**ENGINEER**  
IIC CONSULTING CONSULTANTS  
1100 S. BURNING WOODS AVENUE, SUITE 4  
RENO, NEVADA 89501

**SHEET INDEX**  
1. PRELIMINARY COVER SHEET  
2. PRELIMINARY SUBDIVISION PLAN  
3. PRELIMINARY SCHEDULE  
4. PRELIMINARY EASEMENT SECTIONS

**LEGEND**  
--- PROJECT BOUNDARY  
--- EXISTING LOT LINE  
--- SECTION CORNER  
--- 1/8" = 1' SCALE  
--- 1/8" = 1' SCALE  
--- 1/8" = 1' SCALE

| LINE NUMBER | DIRECTION  | LENGTH |
|-------------|------------|--------|
| L1          | N 77°04' E | 10.000 |
| L2          | N 82°58' E | 10.000 |
| L3          | N 74°00' E | 10.000 |
| L4          | N 88°00' E | 10.000 |
| L5          | N 82°58' E | 10.000 |
| L6          | N 77°04' E | 10.000 |
| L7          | N 74°00' E | 10.000 |
| L8          | N 88°00' E | 10.000 |
| L9          | N 82°58' E | 10.000 |
| L10         | N 77°04' E | 10.000 |
| L11         | N 82°58' E | 10.000 |

- REFERENCES**
1. SUBDIVISION TRACT MAP No. 3422, DOCUMENT No. 0237947
  2. REVISION TRACT MAP No. 3459, DOCUMENT No. 041638
  3. PROJECT MAP No. 2017883, DOCUMENT No. 2017883
  4. SUBDIVISION TRACT MAP No. 4712, DOCUMENT No. 345123
  5. PROJECT MAP No. 2017883, DOCUMENT No. 2017883



THIS TENTATIVE SUBDIVISION MAP HAS BEEN PREPARED IN ACCORDANCE WITH THE APPLICABLE PROVISIONS OF THE NEVADA COUNTY DEVELOPMENT CODE.

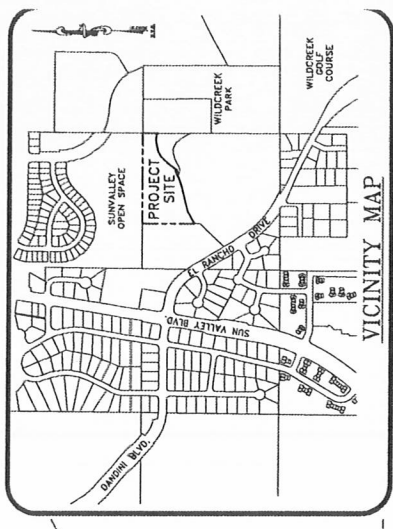

# FALCON RIDGE NORTH TENTATIVE MAP



**PROJECT / LAND USE DATA**  
 TOTAL NUMBER OF LOTS ..... 32  
 GROSS RESIDENTIAL FRONTAGE ..... 2,332 LF - ACRES  
 ALL REGULATIONS  
 LOTS BEHOLDERS ..... 1,877 E./I.  
 AVERAGE LOT SIZE ..... 72.85 SF  
 LOT AREA BEHOLDERS ..... 1,930 ACRES  
 PRIVATE STREET AREA (LOT-187) ..... 0.50 ACRES  
 PRIVATE STREET AREA (LOT-187) ..... 0.11 ACRES  
 COMMON AREA ..... 0.34 ACRES  
 CURRENT ZONING ..... 15 SPACES  
 OTHER SPACES PROVIDED ..... 15 SPACES  
 NOTES: THIS TENTATIVE MAP  
 INCLUDES THE LOTS, PRIVATE STREETS,  
 DOES NOT INCLUDE DEDICATED PARCEL.

**UTILITY DATA**  
 CABLE ..... CHARTER COMMUNICATIONS  
 ELECTRIC ..... ALTAIR ELECTRIC COMPANY  
 GAS ..... FORTY EIGHT ENERGY SERVICES (CON-247)  
 SANITARY SEWER (CON-247) ..... WADSWORTH COUNTY  
 SOLID WASTE ..... WADSWORTH COUNTY  
 WASTE MANAGEMENT ..... WADSWORTH COUNTY  
 WATER ..... TRINICEE MAJOR'S WATER AUTHORITY

**NOTES:**  
 1. ALL STREET SERVICES WITHIN THE TYPICAL LOT ARE PRIVATELY OWNED AND MAINTAINED BY THE HOA OF CONDOMINIUM.  
 2. SEE SHEET 8 FOR STREET CROSSES-SECTIONS.  
 3. PAVED AND CURBED AND PAVED AND UNCURBED SOURCE.



## BASIS OF BEARING

THE MAP-SUBMITTAL STATE PLANNING ACT (NRS 201.010) COORDINATE GRID GROUND COORDINATES ARE SHOWN AND WERE OBTAINED BY MULTIPLE THE GRID COORDINATES BY A 30' ALL DISTANCES SHOWN ARE BEARING DISTANCES. 3/28/18, 8/7/18 (MS).

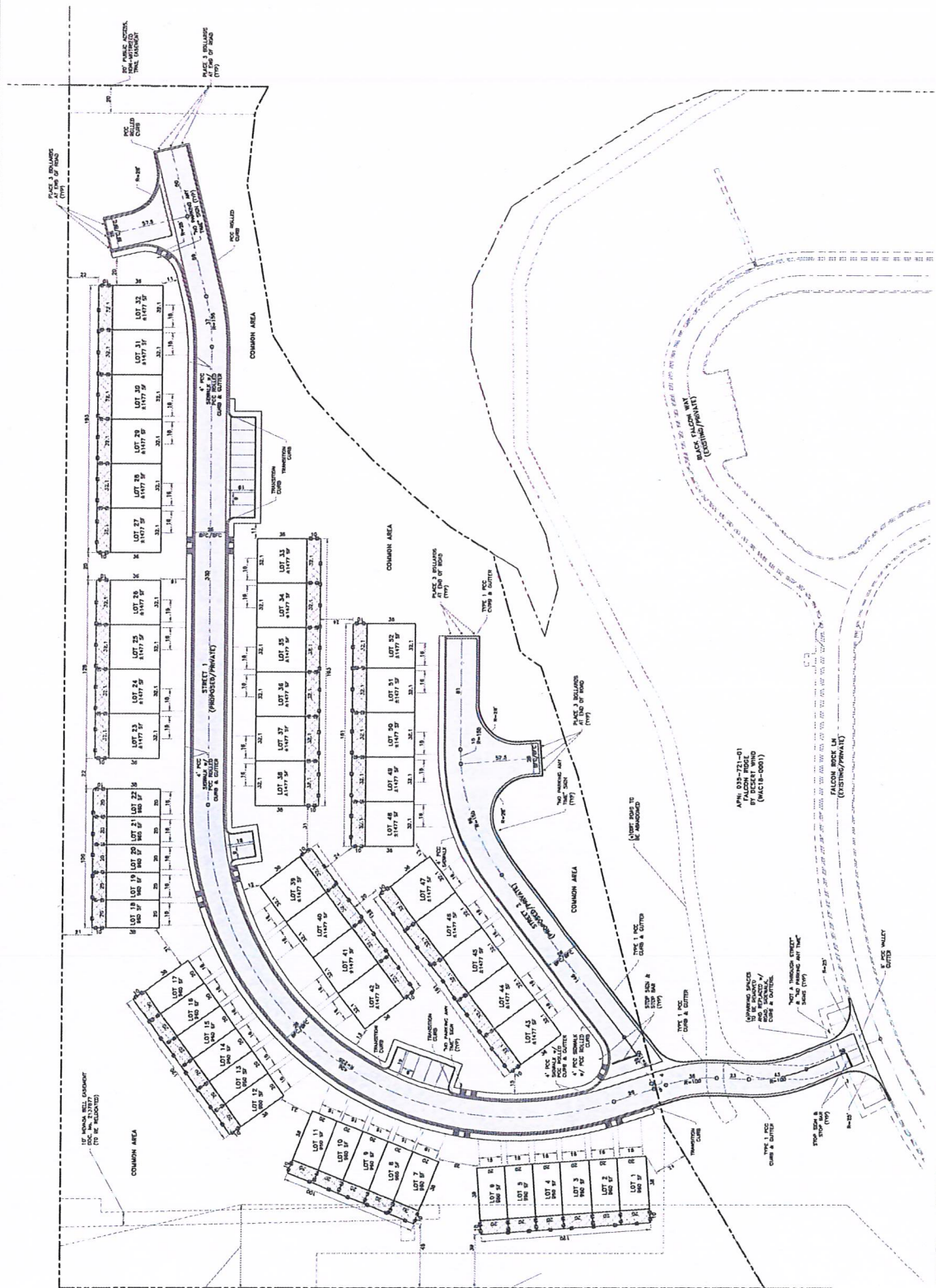

**LEGEND**

|          |                             |
|----------|-----------------------------|
| (Symbol) | BOUNDARY                    |
| (Symbol) | EXISTING LOT LINE           |
| (Symbol) | PROPOSED LOT LINE           |
| (Symbol) | PROPOSED ALL-PURPOSE AREA   |
| (Symbol) | PROPOSED COMMON AREA        |
| (Symbol) | PROPOSED PAVED ROADING AREA |
| (Symbol) | PROPOSED DRIVE              |
| (Symbol) | BOUNDARY                    |
| (Symbol) | BOUNDARY TO BE EXERCISED    |

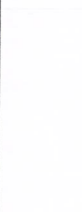



# FALCON RIDGE NORTH TENTATIVE MAP

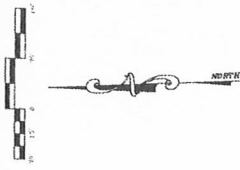

- LEGEND**
- PROJECT BOUNDARY
  - PERMITS OF USE
  - A.C. PROPERTY LINE
  - EXISTING DRIVE
  - PROPOSED DRIVE
  - DRIVE DRIVE (S)
  - DRIVE DRIVE (W)
  - DRIVE DRIVE (N)
  - DRIVE DRIVE (E)
  - DRIVE DRIVE (SE)
  - DRIVE DRIVE (SW)
  - DRIVE DRIVE (NE)
  - DRIVE DRIVE (NW)
  - DRIVE DRIVE (S/W)
  - DRIVE DRIVE (N/E)
  - DRIVE DRIVE (S/E)
  - DRIVE DRIVE (N/W)
  - SANITARY POND
  - SANITARY POND (W)
  - SANITARY POND (N)
  - SANITARY POND (E)
  - SANITARY POND (SE)
  - SANITARY POND (SW)
  - SANITARY POND (NE)
  - SANITARY POND (NW)
  - SANITARY POND (S/W)
  - SANITARY POND (N/E)
  - SANITARY POND (S/E)
  - SANITARY POND (N/W)
  - SANITARY POND (S/E/W)
  - SANITARY POND (N/W/E)
  - SANITARY POND (S/W/E)
  - SANITARY POND (N/E/W)
  - SANITARY POND (S/E/W/N)
  - SANITARY POND (N/W/E/S)
  - SANITARY POND (S/W/E/N)
  - SANITARY POND (N/E/W/S)
  - SANITARY POND (S/E/W/N/W)
  - SANITARY POND (N/W/E/S/E)
  - SANITARY POND (S/W/E/N/S)
  - SANITARY POND (N/E/W/S/W)
  - SANITARY POND (S/E/W/N/E)
  - SANITARY POND (N/W/E/S/N)
  - SANITARY POND (S/W/E/N/W/S)
  - SANITARY POND (N/E/W/S/E/N)
  - SANITARY POND (S/W/E/N/S/W)
  - SANITARY POND (N/E/W/S/E/N/E)
  - SANITARY POND (S/W/E/N/S/W/S)
  - SANITARY POND (N/E/W/S/E/N/W)
  - SANITARY POND (S/W/E/N/S/W/E)
  - SANITARY POND (N/E/W/S/E/N/E/S)
  - SANITARY POND (S/W/E/N/S/W/E/N)
  - SANITARY POND (N/E/W/S/E/N/W/S)
  - SANITARY POND (S/W/E/N/S/W/E/N/E)
  - SANITARY POND (N/E/W/S/E/N/W/S/E)
  - SANITARY POND (S/W/E/N/S/W/E/N/W)
  - SANITARY POND (N/E/W/S/E/N/W/S/E/N)
  - SANITARY POND (S/W/E/N/S/W/E/N/W/S)
  - SANITARY POND (N/E/W/S/E/N/W/S/E/N/E)
  - SANITARY POND (S/W/E/N/S/W/E/N/W/S/E)
  - SANITARY POND (N/E/W/S/E/N/W/S/E/N/W)
  - SANITARY POND (S/W/E/N/S/W/E/N/W/S/E/N)
  - SANITARY POND (N/E/W/S/E/N/W/S/E/N/W/S)
  - SANITARY POND (S/W/E/N/S/W/E/N/W/S/E/N/E)
  - SANITARY POND (N/E/W/S/E/N/W/S/E/N/W/S/E)
  - SANITARY POND (S/W/E/N/S/W/E/N/W/S/E/N/W)
  - SANITARY POND (N/E/W/S/E/N/W/S/E/N/W/S/E/N)
  - SANITARY POND (S/W/E/N/S/W/E/N/W/S/E/N/W/S)
  - SANITARY POND (N/E/W/S/E/N/W/S/E/N/W/S/E/N/E)
  - SANITARY POND (S/W/E/N/S/W/E/N/W/S/E/N/W/S/E)
  - SANITARY POND (N/E/W/S/E/N/W/S/E/N/W/S/E/N/W/S)
  - SANITARY POND (S/W/E/N/S/W/E/N/W/S/E/N/W/S/E/N/E)
  - SANITARY POND (N/E/W/S/E/N/W/S/E/N/W/S/E/N/W/S/E)
  - SANITARY POND (S/W/E/N/S/W/E/N/W/S/E/N/W/S/E/N/W/S)
  - SANITARY POND (N/E/W/S/E/N/W/S/E/N/W/S/E/N/W/S/E/N)
  - SANITARY POND (S/W/E/N/S/W/E/N/W/S/E/N/W/S/E/N/W/S/E/N)
  - SANITARY POND (N/E/W/S/E/N/W/S/E/N/W/S/E/N/W/S/E/N/E)
  - SANITARY POND (S/W/E/N/S/W/E/N/W/S/E/N/W/S/E/N/W/S/E/N/E/N)
  - SANITARY POND (N/E/W/S/E/N/W/S/E/N/W/S/E/N/W/S/E/N/W/S)
  - SANITARY POND (S/W/E/N/S/W/E/N/W/S/E/N/W/S/E/N/W/S/E/N/E/N/E)
  - SANITARY POND (N/E/W/S/E/N/W/S/E/N/W/S/E/N/W/S/E/N/W/S/E/N)
  - SANITARY POND (S/W/E/N/S/W/E/N/W/S/E/N/W/S/E/N/W/S/E/N/W/S/E/N)
  - SANITARY POND (N/E/W/S/E/N/W/S/E/N/W/S/E/N/W/S/E/N/W/S/E/N/E)
  - SANITARY POND (S/W/E/N/S/W/E/N/W/S/E/N/W/S/E/N/W/S/E/N/W/S/E/N/E/N)
  - SANITARY POND (N/E/W/S/E/N/W/S/E/N/W/S/E/N/W/S/E/N/W/S/E/N/E/N/E)
  - SANITARY POND (S/W/E/N/S/W/E/N/W/S/E/N/W/S/E/N/W/S/E/N/W/S/E/N/E/N/E/N)
  - SANITARY POND (N/E/W/S/E/N/W/S/E/N/W/S/E/N/W/S/E/N/W/S/E/N/W/S)
  - SANITARY POND (S/W/E/N/S/W/E/N/W/S/E/N/W/S/E/N/W/S/E/N/W/S/E/N/E/N/E/N/E)
  - SANITARY POND (N/E/W/S/E/N/W/S/E/N/W/S/E/N/W/S/E/N/W/S/E/N/W/S/E/N)
  - SANITARY POND (S/W/E/N/S/W/E/N/W/S/E/N/W/S/E/N/W/S/E/N/W/S/E/N/E/N/E/N/E/S)
  - SANITARY POND (N/E/W/S/E/N/W/S/E/N/W/S/E/N/W/S/E/N/W/S/E/N/W/S/E/N/S)
  - SANITARY POND (S/W/E/N/S/W/E/N/W/S/E/N/W/S/E/N/W/S/E/N/W/S/E/N/E/N/E/N/E/S/E)
  - SANITARY POND (N/E/W/S/E/N/W/S/E/N/W/S/E/N/W/S/E/N/W/S/E/N/W/S/E/N/S/E)
  - SANITARY POND (S/W/E/N/S/W/E/N/W/S/E/N/W/S/E/N/W/S/E/N/W/S/E/N/E/N/E/N/E/S/E/S)
  - SANITARY POND (N/E/W/S/E/N/W/S/E/N/W/S/E/N/W/S/E/N/W/S/E/N/W/S/E/N/S/E/S)
  - SANITARY POND (S/W/E/N/S/W/E/N/W/S/E/N/W/S/E/N/W/S/E/N/W/S/E/N/E/N/E/N/E/S/E/S/S)
  - SANITARY POND (N/E/W/S/E/N/W/S/E/N/W/S/E/N/W/S/E/N/W/S/E/N/W/S/E/N/S/E/S/S)
  - SANITARY POND (S/W/E/N/S/W/E/N/W/S/E/N/W/S/E/N/W/S/E/N/W/S/E/N/E/N/E/N/E/S/E/S/S/S)
  - SANITARY POND (N/E/W/S/E/N/W/S/E/N/W/S/E/N/W/S/E/N/W/S/E/N/W/S/E/N/S/E/S/S/S)
  - SANITARY POND (S/W/E/N/S/W/E/N/W/S/E/N/W/S/E/N/W/S/E/N/W/S/E/N/E/N/E/N/E/S/E/S/S/S/S)



- NOTES:**
1. PROPOSED STORM DRAIN SYSTEM TO BE PUBLICLY OWNED AND MAINTAINED.
  2. ALL PROPOSED SANITARY SEWER SYSTEM TO BE PUBLICLY OWNED AND MAINTAINED.
  3. PROPOSED WATERSHED SYSTEM TO BE OWNED AND MAINTAINED BY THE TENNESSEE WATERSHED AUTHORITY (TWA).
  4. PROPOSED RETENTION POND TO BE PRIVATELY OWNED AND MAINTAINED BY THE OWNER OF THE PROPERTY.
  5. RETENTION POND OUTLET STRUCTURE TO BE SIZED WITH FINAL DESIGN.

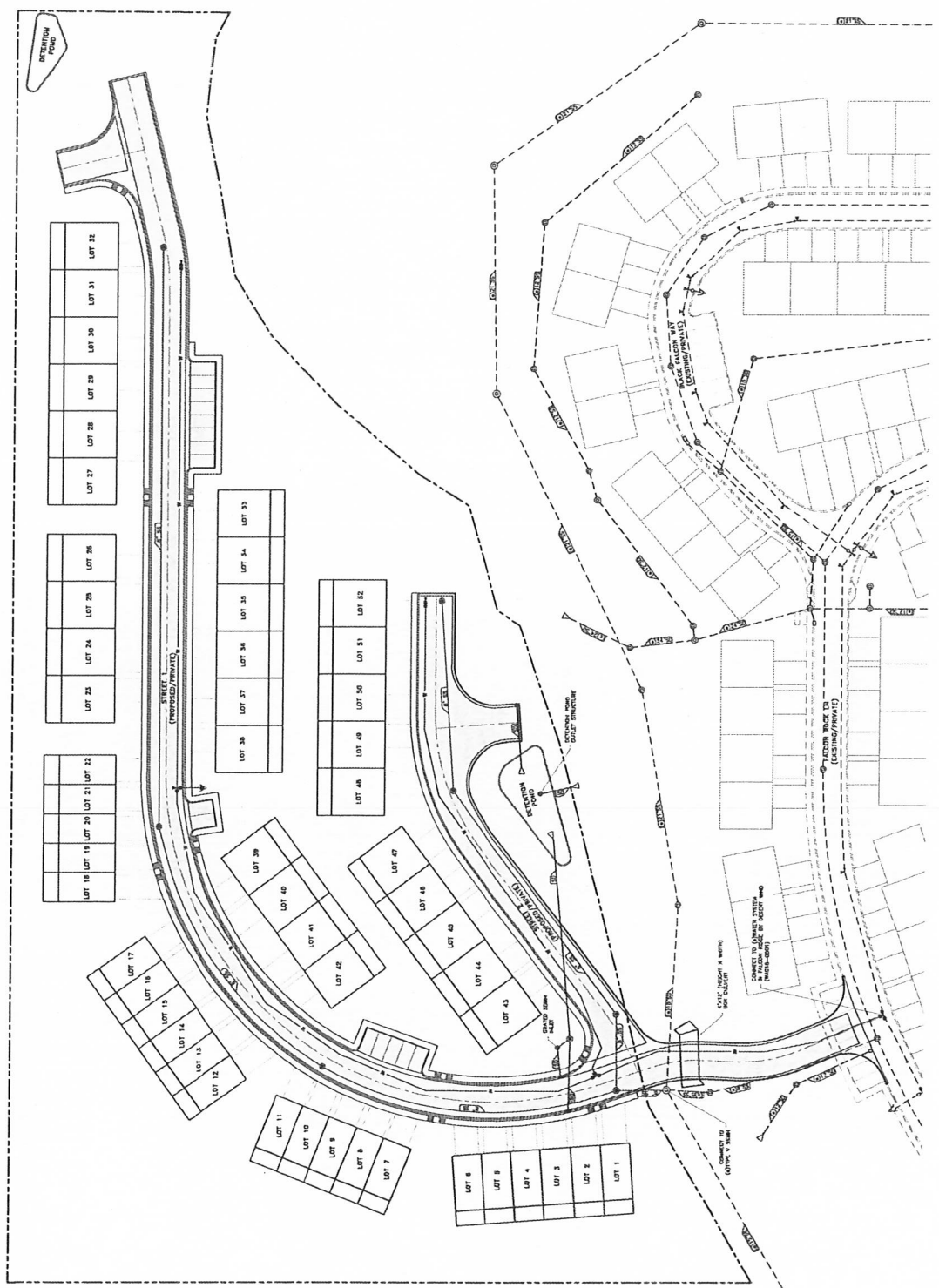

# FALCON RIDGE NORTH TENTATIVE MAP

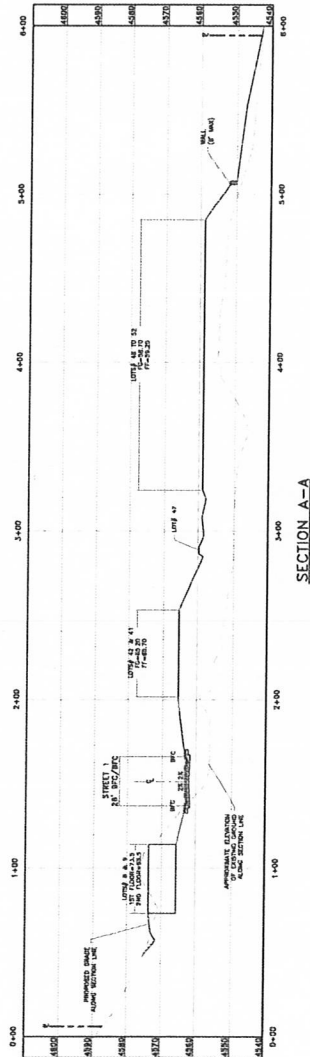
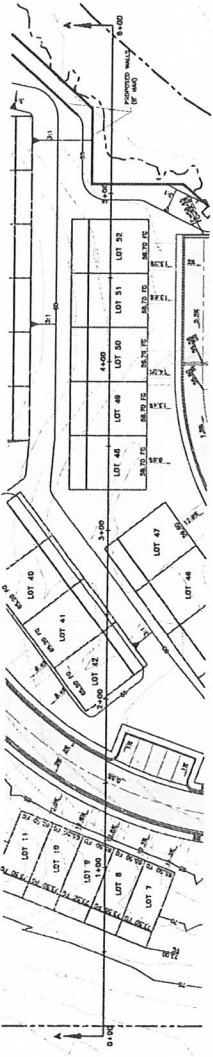

SECTION A-A

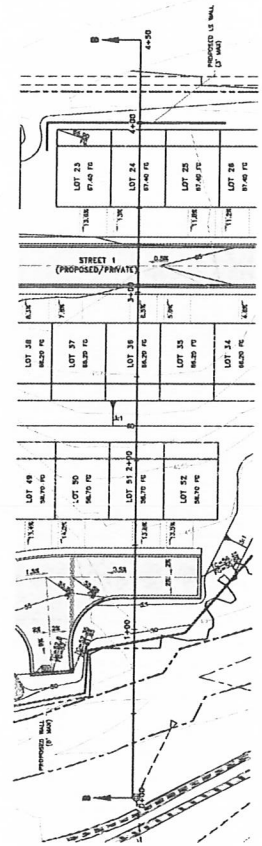

SECTION B-B

HORIZONTAL SCALE  
1"=40'

VERTICAL SCALE  
1"=15'

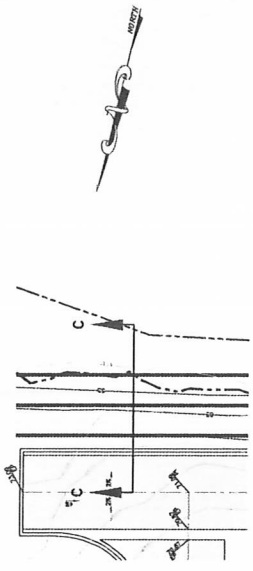

SECTION C-C

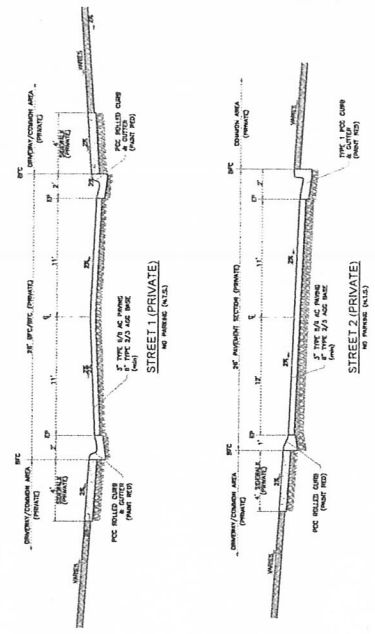

NOTES:  
1. ADD 4000 FEET TO ALL SPOT ELEVATIONS  
2. REF. GRADING PLAN FOR CROSS-SECTION LOCATIONS.



**PRELIMINARY SANITARY SEWER REPORT**

**TO SUPPORT THE**

**FALCON RIDGE NORTH  
TENTATIVE MAP**

**PREPARED FOR:**

**DESERT WIND, LLC  
550 CALIFORNIA AVE.  
RENO, NV 89509**

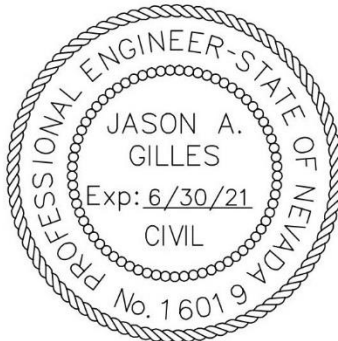

**PREPARED BY:**



**CIVIL  
ENGINEERING  
CONSULTANTS**

**JOB #: DESERTWIND.016  
DATE: AUGUST 15<sup>TH</sup>, 2019**

## Table of Contents

|   |   |
|---|---|
| 1. Introduction .....                   | 1 |
| 2. Methodology.....                     | 1 |
| 3. Existing Sanitary Sewer System.....  | 1 |
| 3.1. Layout.....                        | 1 |
| 3.2. Capacity.....                      | 1 |
| 4. Proposed Sanitary Sewer System ..... | 2 |
| 4.1. Layout.....                        | 2 |
| 4.2. Proposed Sewage Demands .....      | 2 |
| 4.1. Capacity.....                      | 2 |
| 5. Demand on Existing Sewer System..... | 3 |
| 6. Discussion & Conclusion .....        | 3 |

### List of Tables

|  |   |
|--|---|
| Table 1: Existing Sewer Capacity.....  | 2 |
| Table 2: Proposed Sewer Capacity ..... | 3 |
| Table 3: Sewer Capacity Summary.....   | 3 |

### List of Figures

|                                       |          |
|---------------------------------------|----------|
| Figure 1: Vicinity Map.....           | APPENDIX |
| Figure 2: Sanitary Sewer Layout ..... | APPENDIX |

## **1. Introduction**

This preliminary sanitary sewer analysis was prepared to support the Falcon Ridge North Tentative Map. The project is a proposed ±6.19 acre, 52-unit subdivision located in APN 035-721-02. The development is in the northeast quarter of Section 30, Township 20 North, Range 20 East, MDM (Vicinity Map – Figure 1). The project is currently zoned for LDU.

## **2. Methodology**

Sanitary sewer flows were estimated utilizing the design criteria in Section Two of the Washoe County Engineering Design Standards. Peak flows for the mains were estimated at 270-gallons per day per residential unit with a minimum Peaking Factor of 3 (±810-gallons/day/residential unit). The Manning’s Equation was utilized with a roughness coefficient (*n*) of 0.012 for PVC pipes to determine the capacities of the sanitary sewer mains.

### **Manning’s Equation:**

$$Q = \frac{1.49}{n} * A * R^{\frac{2}{3}} * S^{\frac{1}{2}} = Flow$$

Where:

- Q = Capacity of pipe (*cubic-feet per second*) (*cfs*)
- *n* = Manning’s runoff coefficient (*unitless*) ~ *n* = 0.012 (proposed PVC mains)
- A = Cross-sectional area (*ft*<sup>2</sup>)
- R = Hydraulic radius (*ft*)
- S = Slope (*ft/ft*)

## **3. Existing Sanitary Sewer System**

### **3.1. Layout**

An existing sanitary sewer trunk main is located in an existing Falcon Ridge Development in the parcel below (APN 035-721-01). This trunk main is 18-in and upsizes to a 21-in main running east. The trunk main eventually connects with infrastructure on El Rancho Drive. The existing sanitary sewer layout can be seen in the Figure 2.

### **3.2. Capacity**

The maximum capacity of the 18-in trunk main was estimated using Manning’s Equation and characteristics found from Civil Improvement As-Builts. The trunk main has a slope of ±0.6% and is estimated to be PVC. The calculations for the main capacity are shown in Table 1.



Table 1: Existing Sewer Capacity

| <b>TABLE 1<br/>EXISTING SEWER CAPACITY</b>                           |                  |  |
|--|------------------|--|
| <b>DIAMETER (IN)</b>   | <b>SLOPE (%)</b> | <b>THEORETICAL FLOW @<br/>50% FULL (cfs)</b> |
| 18   | 0.6              | 4.02   |
| <b>PRELIMINARY SEWER REPORT<br/>FALCON RIDGE NORTH TENTATIVE MAP</b> |                  |  |

The maximum estimated capacity of the trunk main is 4.02-cfs at 50% full.

#### **4. Proposed Sanitary Sewer System**

##### **4.1. Layout**

The proposed sanitary sewer system will consist of 8-inch diameter mains that gravity flow along Street 1 and Street 2. The two mains will intersect at the south end of Street 1, where they will connect directly to the 18-in trunk main. All proposed sewer system will be publicly owned and maintained. All mains, with final design, will have a minimum velocity of 2.5 ft/s when flowing half full. The proposed sewer system can be seen in Figure 2 in the Appendix.

##### **4.2. Proposed Sewage Demands**

Utilizing the design criteria in Section Two of the Washoe County Engineering Design Standards, the proposed 52-unit subdivision is estimated to generate 54,600-GPD (0.084-CFS) at peak flow. The estimated peak flows are assumed to be that of single-family residential dwelling units.

The following assumptions were made:

- 52 – Single-Family Residential Units
- Average Daily Residential Rate = 270 gallons/day
- Minimum Peaking Factor (PF) ~ Per Section Two = 3
- 270 gallons/day (Residential Rate) \* 3.0 (PF) = ±810 gallons/day per Residential Unit (peak flow)

#### **Calculations:**

$$52 \text{ Residential Units} * 810 \frac{\text{gpd}}{\text{Residential Unit}} = 42,120 \text{ gpd (0.065 cfs)}$$

##### **4.1. Capacity**

With the maximum combined flow of 42,120-gpd (0.065-CFS) produced from the Falcon Ridge North Development, the proposed sewer main is anticipated to handle the estimated peak flows. To calculate the main capacity, an 8-in PVC pipe with a slope of 0.5% was used to calculate the

theoretical demand to compare to the peak flow. This slope maintains a 2.5 ft/s velocity while flowing 50% full. Table 2 shows the proposed sewer capacity for an 8-in main.

Table 2: Proposed Sewer Capacity

| <b>TABLE 2<br/>PROPOSED SEWER CAPACITY</b>                           |                      |  |  |               |
|--|----------------------|--|--|---------------|
| <b>DIAMETER<br/>(IN)</b>   | <b>SLOPE<br/>(%)</b> | <b>THEORETICAL<br/>FLOW @ 50% FULL<br/>(cfs)</b> | <b>ESTIMATED<br/>FLOW DEMAND<br/>(cfs)</b> | <b>% FULL</b> |
| 8  | 0.5                  | 0.463  | 0.065                                      | 14%           |
| <b>PRELIMINARY SEWER REPORT<br/>FALCON RIDGE NORTH TENTATIVE MAP</b> |                      |  |  |               |

The maximum theoretical capacity of an 8-in sewer main with a minimum slope of 0.5% is 0.463-cfs. The proposed main has more than enough capacity to convey the proposed flows.

**5. Demand on Existing Sewer System**

With the estimated flow produced by Falcon Ridge North, and the theoretical capacity of the trunk main, the impacts on the existing system were analyzed. The total increase in the capacity of the trunk main can be seen in Table 3.

Table 3: Sewer Capacity Summary

| <b>TABLE 3<br/>SEWER CAPACITY SUMMARY</b>                            |                                       |   |
|--|---------------------------------------|---|
| <b>THEORETICAL FLOW<br/>@ 50% FULL (cfs)</b>                         | <b>PROPOSED FLOW<br/>DEMAND (cfs)</b> | <b>% OF TOTAL<br/>CAPACITY @ 50%<br/>FULL</b> |
| 4.02   | 0.065                                 | 2%  |
| <b>PRELIMINARY SEWER REPORT<br/>FALCON RIDGE NORTH TENTATIVE MAP</b> |                                       |   |

With the proposed peak flows added to the trunk main, the flow increase compared to the total capacity at 50% full is estimated to be ±2%.

**6. Discussion & Conclusion**

The proposed system will follow the design criteria listed in Section two of the Washoe County Engineering Design Standards. The proposed development will connect directly to an existing 18-in trunk main. The existing trunk main has more than enough capacity to convey the proposed flows, with only an increase of ±2% of the maximal flow capacity at 50% full within the main. There is currently no existing infrastructure in the proposed site, and the additional flows will not

impact other facilities. As such, no adverse effects are anticipated to the adjacent or downstream sanitary sewer mains.

# APPENDIX

➤ FIGURE 1: VICINITY MAP

➤ FIGURE 2: SANITARY SEWER LAYOUT

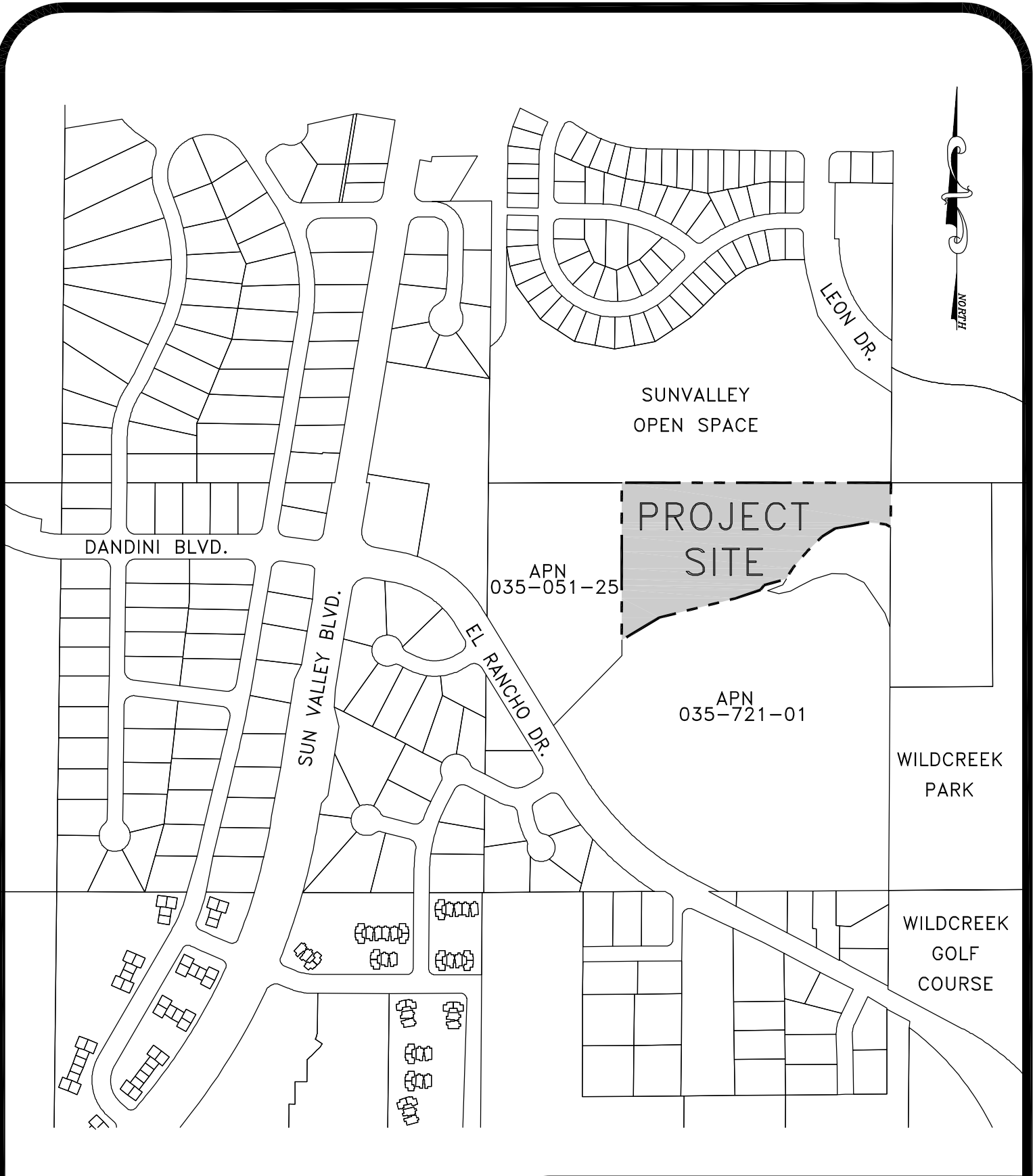

# VICINITY MAP

N.T.S.

PRELIMINARY SEWER REPORT  
TO SUPPORT THE  
FALCON RIDGE NORTH  
TENTATIVE MAP  
FIGURE 1

APN  
035-370-01  
WASHOE COUNTY  
REGIONAL OPEN

APN  
035-051-25  
SIERRA POINT, LLC



APN  
035-721-02  
FALCON RIDGE NORTH  
BY DESERT WIND

APN  
035-051-22  
CITY OF  
SPARKS

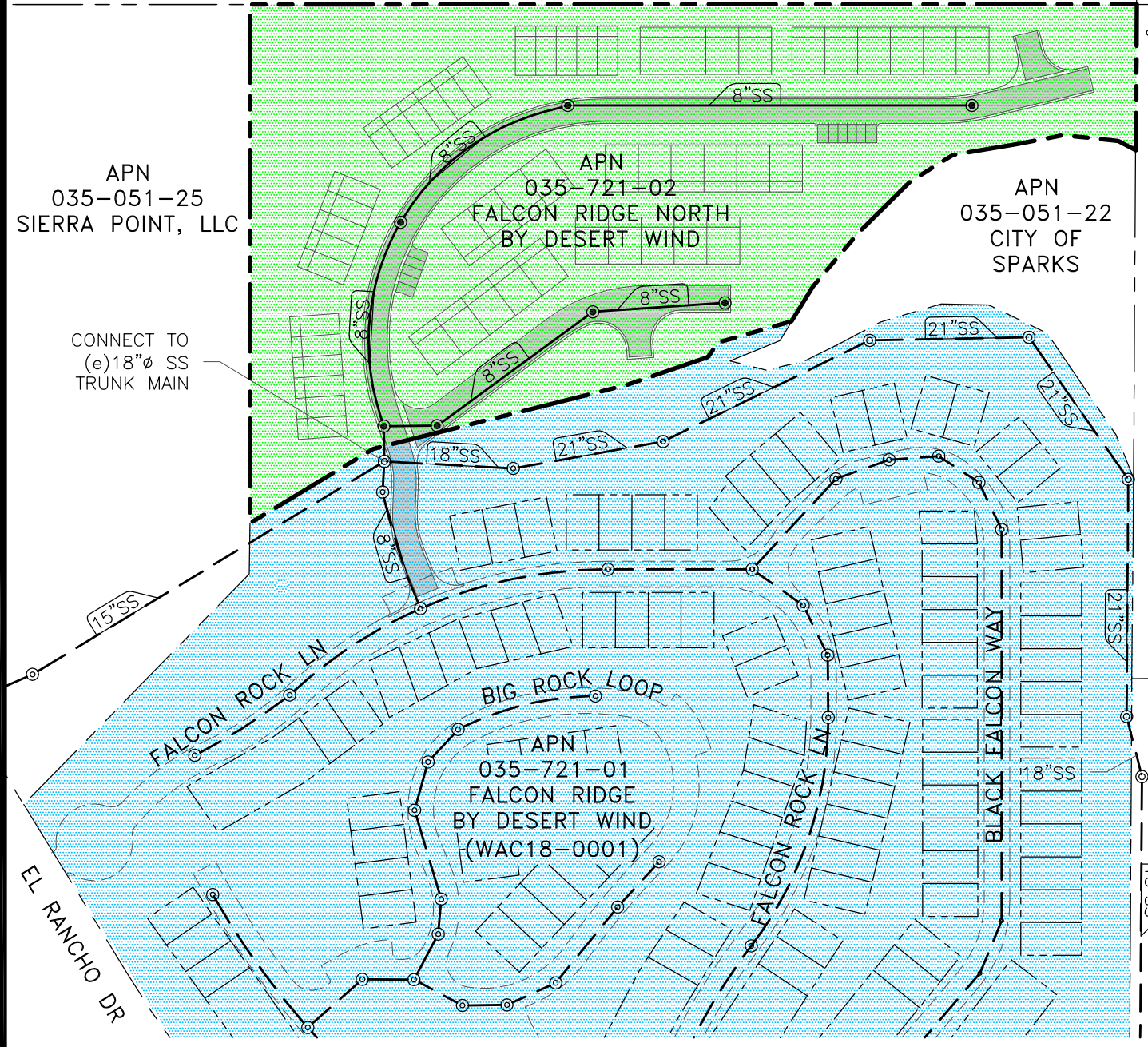
CONNECT TO  
(e)18"Ø SS  
TRUNK MAIN

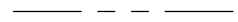
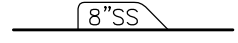

**LEGEND**

-  PROJECT BOUNDARY
-  EXISTING LOT LINE
-  SS MAIN w/ DIAMETER & DIRECTION  
(DASHED IF EXISTING)
-  FALCON RIDGE NORTH  
(52 UNITS)
-  FALCON RIDGE (WAC18-0001)  
(142 UNITS)

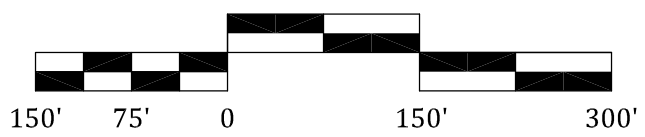

PRELIMINARY SEWER REPORT  
TO SUPPORT THE  
FALCON RIDGE NORTH  
TENTATIVE MAP  
FIGURE 2  
SEWER LAYOUT

**PRELIMINARY HYDROLOGY REPORT**

**TO SUPPORT THE**

**FALCON RIDGE NORTH  
TENTATIVE MAP**

**PREPARED FOR:**

**DESERT WIND, LLC  
550 CALIFORNIA AVE.  
RENO, NV 89509**

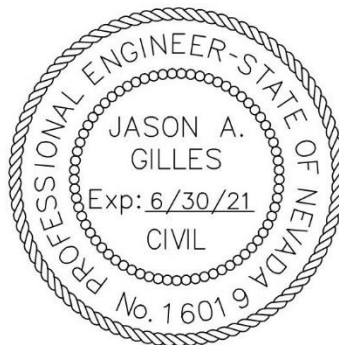

**PREPARED BY:**



**CIVIL  
ENGINEERING  
CONSULTANTS**

**JOB #: DESERTWIND016  
DATE: 08/15/2019**

## Table of Contents

|   |   |
|---|---|
| 1. Introduction .....                           | 1 |
| 1.1. Previous Studies .....                     | 1 |
| 1.2. Flood Zone .....                           | 1 |
| 1.3. Methodology .....                          | 1 |
| 1.3.1. Time of Concentration (Tc) .....         | 1 |
| 2. Existing Runoff Conditions .....             | 2 |
| 2.1. Existing Runoff Patterns .....             | 2 |
| 2.2. Existing Storm Drain System .....          | 2 |
| 2.3. Calculations .....                         | 2 |
| 3. Proposed Runoff Conditions .....             | 3 |
| 3.1. Proposed Runoff Patterns .....             | 3 |
| 3.2. Calculations .....                         | 3 |
| 3.3. Detention Pond Volume and Discharge .....  | 3 |
| 3.3.1. Detention Pond Volume Calculations ..... | 4 |
| 4. Discussion/ Conclusions .....                | 4 |
| 5. References .....                             | 5 |

### List of Tables

|   |   |
|---|---|
| Table 1: Existing Drainage Basins Hydrology ..... | 3 |
| Table 2: Proposed Drainage Basins Hydrology ..... | 4 |
| Table 3: Detention Summary .....                  | 4 |

### List of Figures

|  |          |
|--|----------|
| Figure 1: Vicinity Map .....             | Appendix |
| Figure 2: Existing Drainage Basins ..... | Appendix |
| Figure 3: Proposed Drainage Basins ..... | Appendix |



## 1. Introduction

This preliminary hydrology report was prepared to support the Falcon Ridge North Tentative Map. Falcon Ridge North is the next phase of the Falcon Ridge Townhomes development, connecting to Falcon Rock Lane. Falcon Ridge North, a proposed 52-lot subdivision, is located in the northeast quarter of Section 30, Township 20 North, Range 20 East, MDM. Reference Figure 1 in the Appendix for the Vicinity Map of the project area.

### 1.1. Previous Studies

A previous hydrology report was written by TEC Civil Engineering Consultants in 2017 supporting the adjacent development of the Falcon Ridge Townhomes.

### 1.2. Flood Zone

The project is located in the Federal Emergency Management Agency (FEMA) Flood Insurance Rate Map (FIRM) 32031C3034G. The Panel is listed in the FEMA FIRM Index Map as being partially within an Unshaded Flood Zone X, Zone X, and Zone AE according to the FEMA National Flood Insurance Program. Reference the Appendix for a copy of the FEMA FIRM Index Map.

### 1.3. Methodology

Due to the limited size of the contributing runoff areas, the Rational Method was utilized in determining the existing and proposed peak runoff rates. The following elements are required in utilizing the Rational Method:

$$Q = C*i*A$$

- C = Rational Method Runoff Coefficient obtained from the City of Reno Design Manual (*unitless*)
- i = Average Rainfall Intensity obtained from the National Oceanic and Atmospheric Administration (NOAA) Atlas (*inches/ hour*)
- A = Watershed area (*acres*)
- Q = Peak runoff flow (*cubic feet/second*)

Both the detention pond and outlet structure will be sized using the Rational Method during final design.

#### 1.3.1. Time of Concentration (Tc)

A maximum time of concentration was determined by utilizing the longest drainage flow path in the particular hydrologic basin. The time of concentration was calculated using the given formula:

Ditch and gutter travel time was calculated using the following equation:

$$t_t = \frac{D}{V} \left( \frac{1}{60} \right)$$

Where:

$t_t$  = ditch and gutter flow time (*minutes*)

D = distance of travel (*feet*)

V = velocity (*feet/second*)

Rainfall intensities were derived from the National Oceanic and Atmospheric Administration (NOAA) Atlas. Time of concentration values were calculated using the Truckee Meadows Regional Drainage Manual and the Time Travel Velocity Figure. According to Washoe County’s design standards, the minimum time of concentration to be used in calculations is 10 minutes. For basins that have a time of concentration under 10 minutes, the minimum value of 10 minutes will be substituted. The time of concentration values for basins with times of concentration over 10 minutes were utilized with their calculated value. These values were applied to the Rational Method to estimate peak flows for both the proposed development and the parcel as it exists currently. A copy of the NOAA Atlas Point Precipitation Frequency Estimate and Time Travel Velocity Figure is provided in the Appendix.

**2. Existing Runoff Conditions**

**2.1. Existing Runoff Patterns**

The proposed Falcon Ridge North site is an undeveloped 6.19-acre parcel with large amounts of desert grasses, weeds, and clay-like soil types. The site has been previously graded, and large soil stockpiles are located on-site. Runoff in this area typically sheet-flows northwest to southeast.

**2.2. Existing Storm Drain System**

The existing storm drain system includes a drainage channel that runs along the northern property line of the project site. This channel captures runoff from the north and northwest directions and conveys the flow easterly. There is an additional channel just south of the property line that conveys runoff easterly.

**2.3. Calculations**

The existing runoff rates were calculated utilizing the Rational Method. Rainfall intensities were determined to be 1.37-inches/hour and 3.44-inches/hour for the 5-year and 100-year storm events, respectively.

**Table 1: Existing Drainage Basins Hydrology**

| AREA   | RUNOFF COEFFICIENT (C) |          | RAINFALL INTENSITY (i) |          | AREA (A)<br>(ACRES) | PEAK RUNOFF RATE (Q)=CiA<br>(FT <sup>3</sup> /SEC) |              |
|--|------------------------|----------|------------------------|----------|---------------------|--|--------------|
|  | (UNITLESS)             |          | (INCHES/HR)            |          |                     | 5-YEAR   | 100-YEAR     |
|  | 5-YEAR                 | 100-YEAR | 5-YEAR                 | 100-YEAR |                     |  |              |
| EX-1   | 0.40                   | 0.50     | 1.37                   | 3.44     | 6.19                | 3.39   | 10.65        |
| CONTRIBUTING-1                                   | 0.40                   | 0.50     | 1.37                   | 3.44     | 11.18               | 6.13   | 19.23        |
| <b>TOTAL=</b>                                    |                        |          |                        |          | <b>17.37</b>        | <b>9.52</b>  | <b>29.88</b> |
| <b>C=0.40 (5-YEAR STORM, UNDEVELOPED AREA)</b>   |                        |          |                        |          |                     |  |              |
| <b>C=0.50 (100-YEAR STORM, UNDEVELOPED AREA)</b> |                        |          |                        |          |                     |  |              |

As indicated in Table 1, approximately 9.52 and 29.88-cfs of peak runoff are generated with predeveloped conditions that will be routed through the site for the 5 and 100-year storm, respectively. Reference Figure 2 in the Appendix for the existing drainage basin layout.

**3. Proposed Runoff Conditions**

**3.1. Proposed Runoff Patterns**

Storm drain pipes, catch basins, drainage swales, and curb and gutters will be utilized throughout the site to maintain proper drive-aisles and prevent flooding. The storm drain infrastructure will be publicly owned and maintained, while the detention ponds and outlet structures will be private. The storm drain system will convey runoff to the proposed detention ponds and existing drainage channel just south of the project’s property line. With final design, the detention ponds and their respective outlet structures will be designed to meter flows out at existing rates. The proposed detention basins can be seen in Figure 3 provided in the Appendix.

**3.2. Calculations**

The proposed conditions were analyzed similarly to the existing conditions. The project site was divided into 7 proposed detention basins that utilized the same rainfall intensities as the existing conditions. The C-Values for the basins were calculated using weighted averages of impervious concrete and asphalt, rooftops, and open space area types given in the Truckee Meadows Regional Drainage Manual.

**Table 2: Proposed Drainage Basins Hydrology**

| AREA  | RUNOFF COEFFICIENT (C) |          | RAINFALL INTENSITY (i) |          | AREA (A)<br>(ACRES) | PEAK RUNOFF RATE (Q)=CiA<br>(FT <sup>3</sup> /SEC) |              |
|---|------------------------|----------|------------------------|----------|---------------------|--|--------------|
|   | (UNITLESS)             |          | (INCHES/HR)            |          |                     | 5-YEAR   | 100-YEAR     |
|   | 5-YEAR                 | 100-YEAR | 5-YEAR                 | 100-YEAR |                     |  |              |
| PRO-1   | 0.70                   | 0.75     | 1.37                   | 3.44     | 2.95                | 2.83   | 7.61         |
| PRO-2   | 0.88                   | 0.93     | 1.37                   | 3.44     | 0.94                | 1.13   | 3.01         |
| PRO-3   | 0.88                   | 0.93     | 1.37                   | 3.44     | 1.25                | 1.51   | 4.00         |
| PRO-4   | 0.50                   | 0.55     | 1.37                   | 3.44     | 1.11                | 0.76   | 2.10         |
| PRO-5   | 0.85                   | 0.90     | 1.37                   | 3.44     | 0.05                | 0.06   | 0.15         |
| CONTRIBUTING-1  | 0.40                   | 0.50     | 1.37                   | 3.44     | 9.28                | 5.09   | 15.96        |
| CONTRIBUTING-2  | 0.40                   | 0.50     | 1.37                   | 3.44     | 1.90                | 1.04   | 3.27         |
| <b>TOTAL=</b>   |                        |          |                        |          | <b>17.48</b>        | <b>12.41</b>                                       | <b>36.10</b> |
| <b>0.88 (C<sub>5-YEAR</sub>) &amp; 0.93 (C<sub>100-YEAR</sub>) (APPROXIMATE VALUES FOR PAVED STREETS/ROOFING)</b> |                        |          |                        |          |                     |  |              |

As indicated in Table 2, approximately 12.41 and 36.10-cfs of peak runoff are generated onsite during the 5 and 100-year storm events, respectively. The total area of the proposed basins is larger than the existing due to the entrance roadway directing flows on-site.

**3.3. Detention Pond Volume and Discharge**

The excess runoff volume will be captured by the proposed detention ponds. Runoff from the site will be restricted through the use of a detention structure that will be sized with final design. The detention summary can be seen in Table 3, showing the excess runoff produced.

**Table 3: Detention Summary**

| AREA                          | RUNOFF COEFFICIENT (C) |          | RAINFALL INTENSITY (i) |          | AREA (A)<br>(ACRES) | PEAK RUNOFF RATE (Q)=CiA<br>(FT <sup>3</sup> /SEC) |             |
|-------------------------------|------------------------|----------|------------------------|----------|---------------------|--|-------------|
|                               | (UNITLESS)             |          | (INCHES/HR)            |          |                     |  |             |
|                               | 5-YEAR                 | 100-YEAR | 5-YEAR                 | 100-YEAR | 5-YEAR              | 100-YEAR   |             |
| EXISTING                      | 0.40                   | 0.50     | 1.37                   | 3.44     | 17.37               | 9.52   | 29.88       |
| PROPOSED                      | VARIES                 | VARIES   | 1.37                   | 3.44     | 17.48               | 12.41  | 36.10       |
| <b>TOTAL AREA/DIFFERENCE=</b> |                        |          |                        |          | <b>17.48</b>        | <b>2.79</b>  | <b>5.94</b> |

As shown in Table 3 below, the increase in peak runoff rates are estimated to be 2.90 and 6.23-cfs for the 5 and 100-year storm, respectively.

Detention volume is calculated by multiplying the time of concentration by the peak flows of the proposed and existing conditions, and then finding the difference between the two. The detention volume required has been calculated to be approximately 3,564-cubic feet to capture the 100-year storm. Calculations and methodology to determine required storage volume is shown below.

**3.3.1. Detention Pond Volume Calculations**

**100-year Required Volume Calculations:**

**Equation = Time of Concentration, Tc (min) \* Peak Runoff Rate (cfs) \* 60 sec/min**

**Existing = 10.00 min \* 29.88 cfs \* 60 sec/min = 17,928 ft<sup>3</sup>**

**Proposed = 10.00 min \* 35.82 cfs \* 60 sec/min = 21,492 ft<sup>3</sup>**

**Total Volume Required = 21,492 ft<sup>3</sup> – 17,928 ft<sup>3</sup> = 3,564 ft<sup>3</sup>**

**Provided Volume Calculations:**

**2,401 ft<sup>2</sup> (Total Detention Pond Area) \* 3 ft (Average Depth/Pond) = 7,203 ft<sup>3</sup>**

The initial estimations and detention pond design show that there is more than enough storage for the 100-year storm event. With final design, the detention ponds will be adequately sized and allow for metered flow that matches historical rates.

**4. Discussion/ Conclusions**

The proposed Falcon Ridge North project will be developed as a 52-lot subdivision. The proposed development will be graded to convey runoff primarily northwest to southeast as per existing runoff conditions. Runoff will be collected and conveyed to detention ponds that will be accurately sized to detain the increase in peak runoff volume from the 5 and 100-year storm events. The ponds will be equipped with outlets sized to restrict discharge to less than existing runoff rates. With the development of the Falcon Ridge North Development and required storm drain improvements, runoff discharge and management will be designed to remain below historic (predeveloped) flow rates and volumes. Therefore, no adverse effects are anticipated to the adjacent or downstream properties.

**5. References**

- *Truckee Meadows Regional Drainage Manual* dated April, 2009
- TEC Civil Engineering Consultants, Falcon Ridge Townhomes Final Hydrology Report, 2017

# APPENDIX

- TRAVEL TIME VELOCITY FIGURE (FIGURE 701)
- NOAA ATLAS POINT PRECIPITATION FREQUENCY ESTIMATE
  - FEMA FIRM MAP #32031C3034G
    - FIGURE 1: VICINITY MAP
    - FIGURE 2: EXISTING DRAINAGE BASINS
    - FIGURE 3: PROPOSED DRAINAGE BASINS

**Figure 15-4** Velocity versus slope for shallow concentrated flow

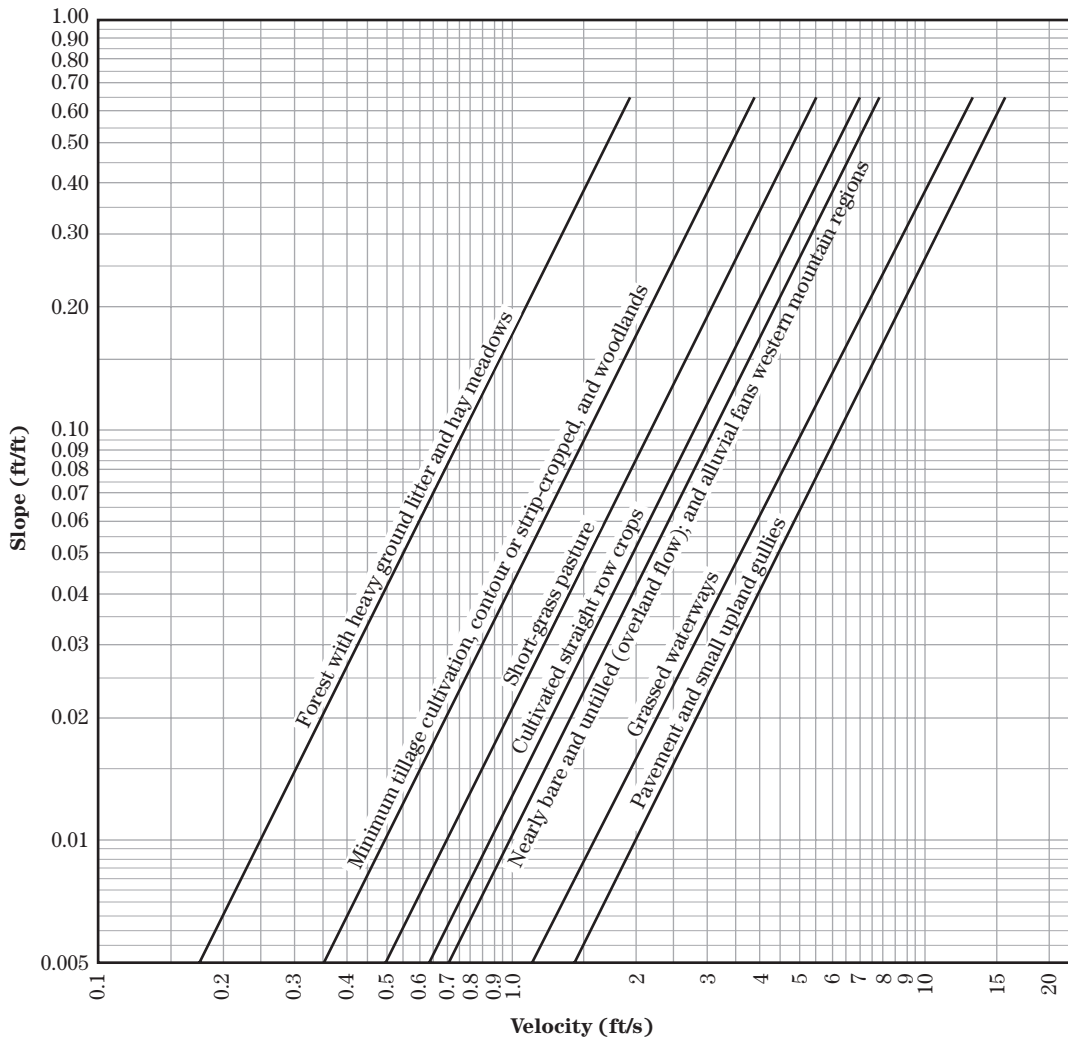

**Table 15-3** Equations and assumptions developed from figure 15-4

| Flow type   | Depth (ft) | Manning's <i>n</i> | Velocity equation (ft/s) |
|---|------------|--------------------|--------------------------|
| Pavement and small upland gullies   | 0.2        | 0.025              | $V = 20.328(s)^{0.5}$    |
| Grassed waterways   | 0.4        | 0.050              | $V = 16.135(s)^{0.5}$    |
| Nearly bare and untilled (overland flow); and alluvial fans in western mountain regions | 0.2        | 0.051              | $V = 9.965(s)^{0.5}$     |
| Cultivated straight row crops   | 0.2        | 0.058              | $V = 8.762(s)^{0.5}$     |
| Short-grass pasture   | 0.2        | 0.073              | $V = 6.962(s)^{0.5}$     |
| Minimum tillage cultivation, contour or strip-cropped, and woodlands                    | 0.2        | 0.101              | $V = 5.032(s)^{0.5}$     |
| Forest with heavy ground litter and hay meadows   | 0.2        | 0.202              | $V = 2.516(s)^{0.5}$     |



**NOAA Atlas 14, Volume 1, Version 5**  
**Location name: Sun Valley, Nevada, USA\***  
**Latitude: 39.5708°, Longitude: -119.7779°**  
**Elevation: 4572.52 ft\*\***



\* source: ESRI Maps  
 \*\* source: USGS

**POINT PRECIPITATION FREQUENCY ESTIMATES**

Sanja Perica, Sarah Dietz, Sarah Heim, Lillian Hiner, Kazungu Maitaria, Deborah Martin, Sandra Pavlovic, Ishani Roy, Carl Trypaluk, Dale Unruh, Fenglin Yan, Michael Yekta, Tan Zhao, Geoffrey Bonnin, Daniel Brewer, Li-Chuan Chen, Tye Parzybok, John Yarchoan

NOAA, National Weather Service, Silver Spring, Maryland

[PF\\_tabular](#) | [PF\\_graphical](#) | [Maps\\_&\\_aerials](#)

**PF tabular**

| <b>PDS-based point precipitation frequency estimates with 90% confidence intervals (in inches/hour)<sup>1</sup></b> |  |                               |                               |                               |                               |                               |                               |                               |                               |                               |
|---|--|-------------------------------|-------------------------------|-------------------------------|-------------------------------|-------------------------------|-------------------------------|-------------------------------|-------------------------------|-------------------------------|
| <b>Duration</b>   | <b>Average recurrence interval (years)</b> |                               |                               |                               |                               |                               |                               |                               |                               |                               |
|   | <b>1</b>                                   | <b>2</b>                      | <b>5</b>                      | <b>10</b>                     | <b>25</b>                     | <b>50</b>                     | <b>100</b>                    | <b>200</b>                    | <b>500</b>                    | <b>1000</b>                   |
| <b>5-min</b>  | <b>1.08</b><br>(0.912-1.24)                | <b>1.33</b><br>(1.13-1.56)    | <b>1.80</b><br>(1.52-2.11)    | <b>2.24</b><br>(1.88-2.65)    | <b>2.99</b><br>(2.46-3.59)    | <b>3.68</b><br>(2.93-4.48)    | <b>4.51</b><br>(3.48-5.57)    | <b>5.52</b><br>(4.09-6.96)    | <b>7.18</b><br>(4.99-9.35)    | <b>8.68</b><br>(5.78-11.6)    |
| <b>10-min</b>   | <b>0.816</b><br>(0.696-0.942)              | <b>1.01</b><br>(0.864-1.19)   | <b>1.37</b><br>(1.16-1.61)    | <b>1.70</b><br>(1.44-2.02)    | <b>2.27</b><br>(1.87-2.73)    | <b>2.80</b><br>(2.23-3.41)    | <b>3.44</b><br>(2.65-4.24)    | <b>4.21</b><br>(3.11-5.30)    | <b>5.46</b><br>(3.80-7.12)    | <b>6.60</b><br>(4.40-8.80)    |
| <b>15-min</b>   | <b>0.676</b><br>(0.576-0.780)              | <b>0.840</b><br>(0.712-0.988) | <b>1.13</b><br>(0.960-1.34)   | <b>1.41</b><br>(1.19-1.67)    | <b>1.88</b><br>(1.55-2.26)    | <b>2.32</b><br>(1.84-2.82)    | <b>2.84</b><br>(2.19-3.50)    | <b>3.48</b><br>(2.58-4.38)    | <b>4.51</b><br>(3.14-5.88)    | <b>5.46</b><br>(3.64-7.27)    |
| <b>30-min</b>   | <b>0.456</b><br>(0.388-0.526)              | <b>0.566</b><br>(0.480-0.664) | <b>0.762</b><br>(0.646-0.898) | <b>0.948</b><br>(0.802-1.12)  | <b>1.26</b><br>(1.04-1.52)    | <b>1.56</b><br>(1.24-1.90)    | <b>1.91</b><br>(1.48-2.36)    | <b>2.34</b><br>(1.73-2.95)    | <b>3.04</b><br>(2.12-3.96)    | <b>3.67</b><br>(2.45-4.89)    |
| <b>60-min</b>   | <b>0.282</b><br>(0.240-0.325)              | <b>0.350</b><br>(0.297-0.411) | <b>0.471</b><br>(0.400-0.556) | <b>0.587</b><br>(0.496-0.696) | <b>0.783</b><br>(0.644-0.939) | <b>0.966</b><br>(0.769-1.17)  | <b>1.18</b><br>(0.913-1.46)   | <b>1.45</b><br>(1.07-1.83)    | <b>1.88</b><br>(1.31-2.45)    | <b>2.27</b><br>(1.52-3.03)    |
| <b>2-hr</b>   | <b>0.188</b><br>(0.166-0.216)              | <b>0.232</b><br>(0.206-0.268) | <b>0.298</b><br>(0.262-0.344) | <b>0.356</b><br>(0.307-0.410) | <b>0.445</b><br>(0.373-0.518) | <b>0.525</b><br>(0.429-0.620) | <b>0.617</b><br>(0.490-0.740) | <b>0.744</b><br>(0.564-0.922) | <b>0.970</b><br>(0.696-1.24)  | <b>1.18</b><br>(0.814-1.53)   |
| <b>3-hr</b>   | <b>0.149</b><br>(0.133-0.168)              | <b>0.185</b><br>(0.167-0.210) | <b>0.232</b><br>(0.207-0.264) | <b>0.270</b><br>(0.239-0.307) | <b>0.324</b><br>(0.282-0.371) | <b>0.371</b><br>(0.316-0.430) | <b>0.428</b><br>(0.358-0.504) | <b>0.504</b><br>(0.411-0.620) | <b>0.652</b><br>(0.507-0.832) | <b>0.791</b><br>(0.592-1.03)  |
| <b>6-hr</b>   | <b>0.104</b><br>(0.094-0.116)              | <b>0.130</b><br>(0.117-0.146) | <b>0.161</b><br>(0.145-0.182) | <b>0.185</b><br>(0.165-0.209) | <b>0.217</b><br>(0.190-0.245) | <b>0.240</b><br>(0.207-0.274) | <b>0.264</b><br>(0.225-0.305) | <b>0.293</b><br>(0.244-0.343) | <b>0.344</b><br>(0.280-0.422) | <b>0.401</b><br>(0.321-0.521) |
| <b>12-hr</b>  | <b>0.067</b><br>(0.061-0.075)              | <b>0.084</b><br>(0.076-0.094) | <b>0.106</b><br>(0.095-0.118) | <b>0.123</b><br>(0.110-0.137) | <b>0.145</b><br>(0.128-0.164) | <b>0.162</b><br>(0.141-0.184) | <b>0.179</b><br>(0.153-0.207) | <b>0.196</b><br>(0.165-0.229) | <b>0.220</b><br>(0.179-0.262) | <b>0.239</b><br>(0.190-0.291) |
| <b>24-hr</b>  | <b>0.042</b><br>(0.038-0.047)              | <b>0.052</b><br>(0.048-0.059) | <b>0.067</b><br>(0.060-0.074) | <b>0.078</b><br>(0.070-0.087) | <b>0.094</b><br>(0.084-0.104) | <b>0.106</b><br>(0.094-0.119) | <b>0.119</b><br>(0.105-0.134) | <b>0.133</b><br>(0.116-0.150) | <b>0.152</b><br>(0.130-0.173) | <b>0.167</b><br>(0.141-0.192) |
| <b>2-day</b>  | <b>0.025</b><br>(0.022-0.028)              | <b>0.031</b><br>(0.028-0.035) | <b>0.040</b><br>(0.036-0.045) | <b>0.047</b><br>(0.042-0.052) | <b>0.057</b><br>(0.050-0.063) | <b>0.064</b><br>(0.057-0.072) | <b>0.072</b><br>(0.063-0.082) | <b>0.081</b><br>(0.070-0.093) | <b>0.093</b><br>(0.078-0.108) | <b>0.102</b><br>(0.085-0.121) |
| <b>3-day</b>  | <b>0.018</b><br>(0.016-0.020)              | <b>0.023</b><br>(0.020-0.025) | <b>0.029</b><br>(0.026-0.033) | <b>0.034</b><br>(0.031-0.038) | <b>0.042</b><br>(0.037-0.047) | <b>0.048</b><br>(0.042-0.054) | <b>0.054</b><br>(0.047-0.061) | <b>0.061</b><br>(0.052-0.069) | <b>0.070</b><br>(0.059-0.081) | <b>0.078</b><br>(0.064-0.091) |
| <b>4-day</b>  | <b>0.014</b><br>(0.013-0.016)              | <b>0.018</b><br>(0.016-0.021) | <b>0.024</b><br>(0.021-0.026) | <b>0.028</b><br>(0.025-0.031) | <b>0.034</b><br>(0.030-0.038) | <b>0.039</b><br>(0.034-0.044) | <b>0.045</b><br>(0.039-0.051) | <b>0.050</b><br>(0.043-0.058) | <b>0.059</b><br>(0.049-0.068) | <b>0.065</b><br>(0.054-0.077) |
| <b>7-day</b>  | <b>0.010</b><br>(0.009-0.011)              | <b>0.012</b><br>(0.011-0.014) | <b>0.016</b><br>(0.014-0.018) | <b>0.019</b><br>(0.017-0.022) | <b>0.023</b><br>(0.020-0.026) | <b>0.027</b><br>(0.023-0.030) | <b>0.030</b><br>(0.026-0.035) | <b>0.034</b><br>(0.029-0.039) | <b>0.039</b><br>(0.033-0.046) | <b>0.044</b><br>(0.036-0.052) |
| <b>10-day</b>   | <b>0.008</b><br>(0.007-0.009)              | <b>0.010</b><br>(0.009-0.011) | <b>0.013</b><br>(0.011-0.014) | <b>0.015</b><br>(0.013-0.017) | <b>0.018</b><br>(0.016-0.021) | <b>0.021</b><br>(0.018-0.024) | <b>0.023</b><br>(0.020-0.027) | <b>0.026</b><br>(0.022-0.030) | <b>0.030</b><br>(0.025-0.035) | <b>0.033</b><br>(0.027-0.039) |
| <b>20-day</b>   | <b>0.005</b><br>(0.004-0.005)              | <b>0.006</b><br>(0.005-0.007) | <b>0.008</b><br>(0.007-0.009) | <b>0.009</b><br>(0.008-0.010) | <b>0.011</b><br>(0.009-0.012) | <b>0.012</b><br>(0.011-0.014) | <b>0.014</b><br>(0.012-0.016) | <b>0.015</b><br>(0.013-0.017) | <b>0.017</b><br>(0.014-0.020) | <b>0.019</b><br>(0.016-0.022) |
| <b>30-day</b>   | <b>0.003</b><br>(0.003-0.004)              | <b>0.004</b><br>(0.004-0.005) | <b>0.006</b><br>(0.005-0.006) | <b>0.007</b><br>(0.006-0.008) | <b>0.008</b><br>(0.007-0.009) | <b>0.009</b><br>(0.008-0.010) | <b>0.010</b><br>(0.009-0.012) | <b>0.011</b><br>(0.010-0.013) | <b>0.013</b><br>(0.011-0.015) | <b>0.014</b><br>(0.012-0.016) |
| <b>45-day</b>   | <b>0.003</b><br>(0.002-0.003)              | <b>0.004</b><br>(0.003-0.004) | <b>0.005</b><br>(0.004-0.005) | <b>0.005</b><br>(0.005-0.006) | <b>0.006</b><br>(0.006-0.007) | <b>0.007</b><br>(0.006-0.008) | <b>0.008</b><br>(0.007-0.009) | <b>0.009</b><br>(0.007-0.010) | <b>0.010</b><br>(0.008-0.011) | <b>0.010</b><br>(0.009-0.012) |
| <b>60-day</b>   | <b>0.002</b><br>(0.002-0.003)              | <b>0.003</b><br>(0.003-0.003) | <b>0.004</b><br>(0.003-0.004) | <b>0.005</b><br>(0.004-0.005) | <b>0.005</b><br>(0.005-0.006) | <b>0.006</b><br>(0.005-0.007) | <b>0.006</b><br>(0.006-0.007) | <b>0.007</b><br>(0.006-0.008) | <b>0.008</b><br>(0.007-0.009) | <b>0.008</b><br>(0.007-0.009) |

<sup>1</sup> Precipitation frequency (PF) estimates in this table are based on frequency analysis of partial duration series (PDS). Numbers in parenthesis are PF estimates at lower and upper bounds of the 90% confidence interval. The probability that precipitation frequency estimates (for a given duration and average recurrence interval) will be greater than the upper bound (or less than the lower bound) is 5%. Estimates at upper bounds are not checked against probable maximum precipitation (PMP) estimates and may be higher than currently valid PMP values. Please refer to NOAA Atlas 14 document for more information.

[Back to Top](#)



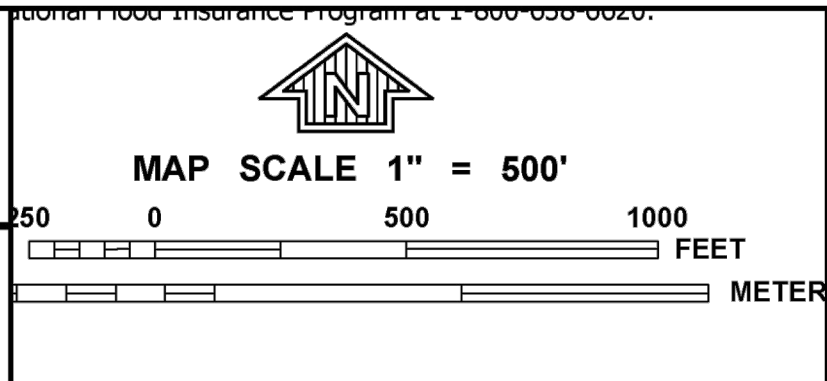
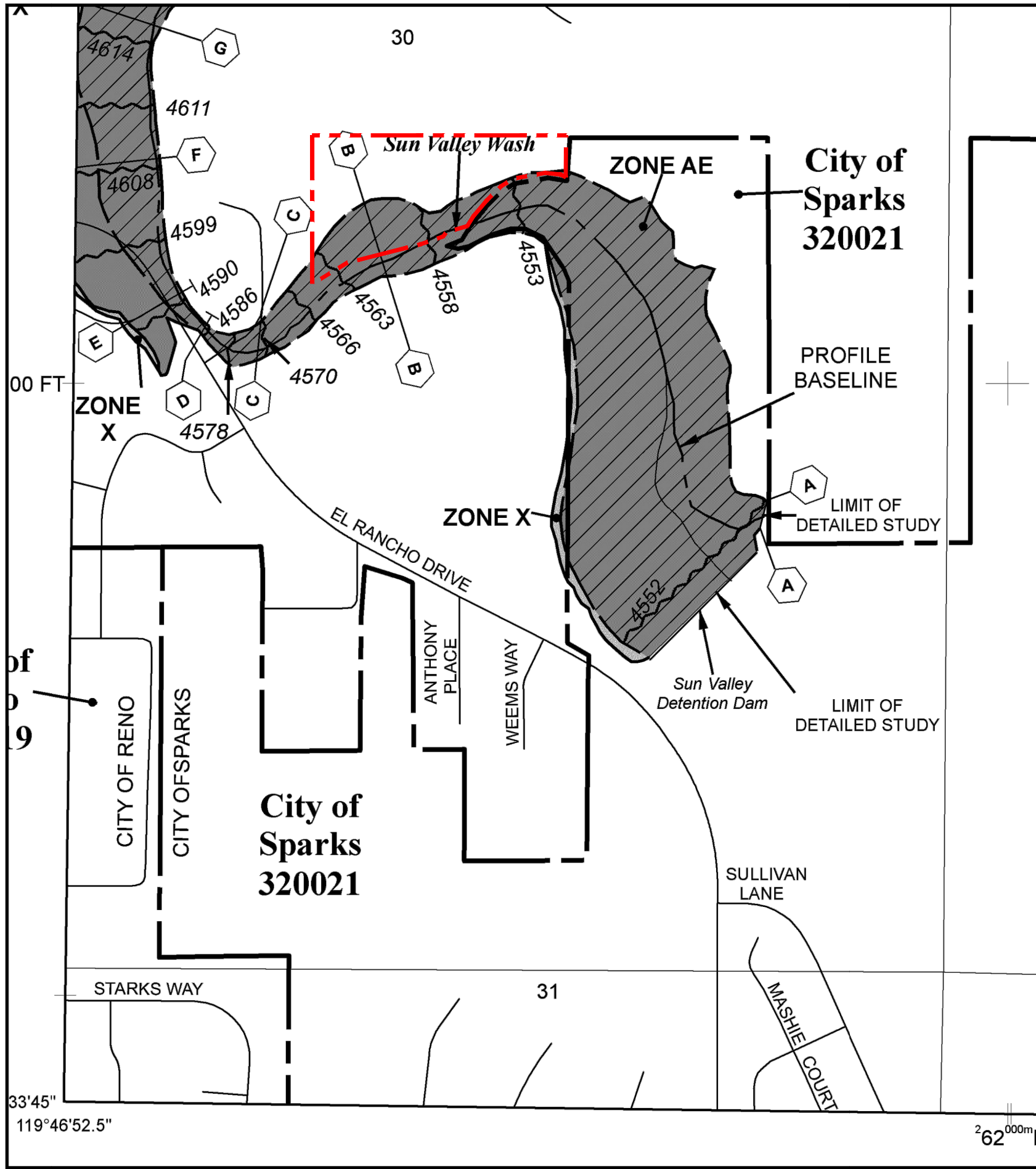

NATIONAL FLOOD INSURANCE PROGRAM

PANEL 3034G

**FIRM**  
FLOOD INSURANCE RATE MAP

WASHOE COUNTY,  
NEVADA  
AND INCORPORATED AREAS

PANEL 3034 OF 3475  
(SEE MAP INDEX FOR FIRM PANEL LAYOUT)

CONTAINS:

| COMMUNITY       | NUMBER | PANEL | SUFFIX |
|-----------------|--------|-------|--------|
| RENO, CITY OF   | 320020 | 3034  | G      |
| SPARKS, CITY OF | 320021 | 3034  | G      |
| WASHOE COUNTY   | 320019 | 3034  | G      |

Notice to User: The Map Number shown below should be used when placing map orders; the Community Number shown above should be used on insurance applications for the subject community.

 MAP NUMBER  
32031C3034G

MAP REVISED  
MARCH 16, 2009

Federal Emergency Management Agency

This is an official copy of a portion of the above referenced flood map. It was extracted using F-MIT On-Line. This map does not reflect changes or amendments which may have been made subsequent to the date on the title block. For the latest product information about National Flood Insurance Program flood maps check the FEMA Flood Map Store at [www.msc.fema.gov](http://www.msc.fema.gov)

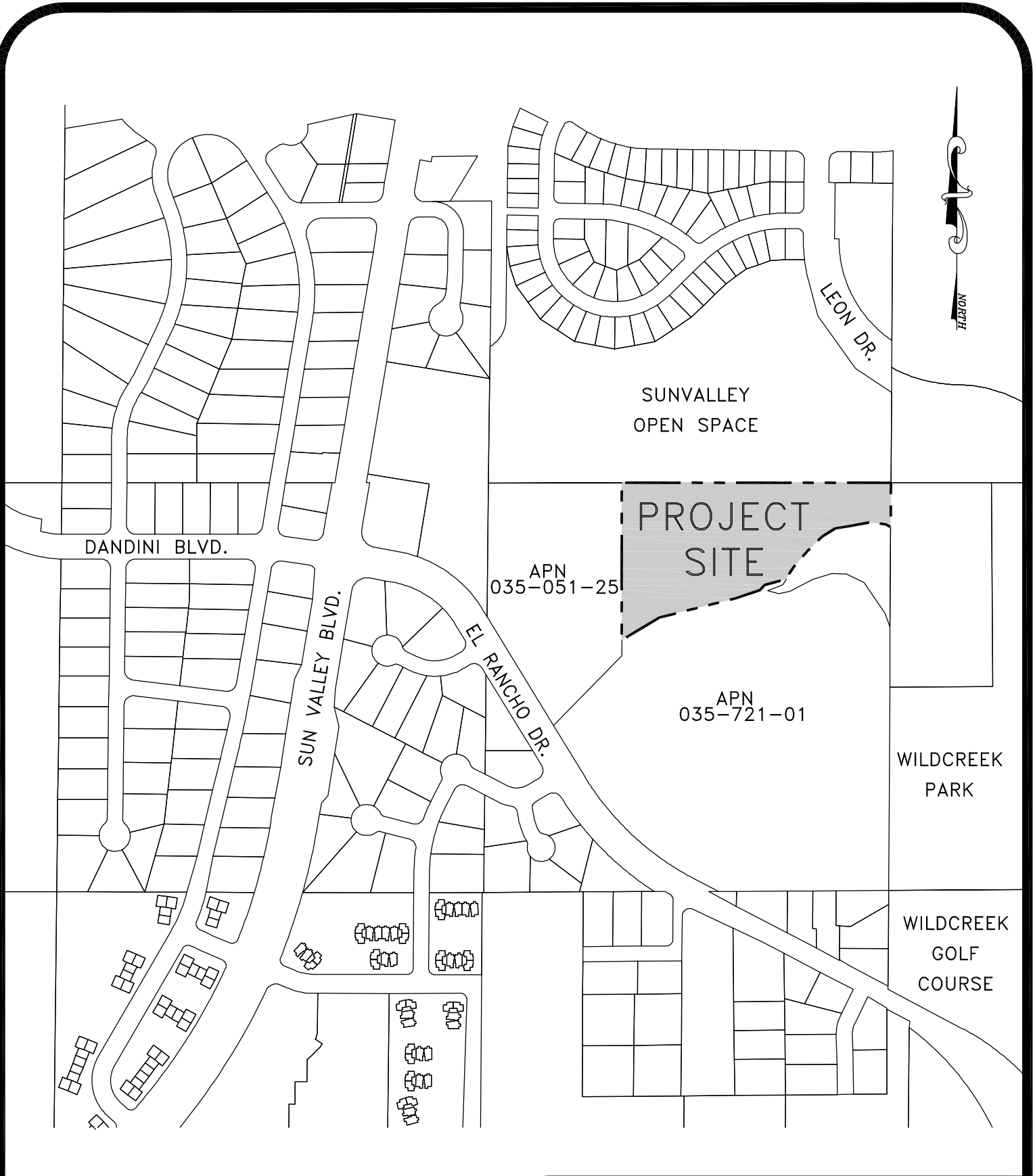

VICINITY MAP

N.T.S.

PRELIMINARY HYDROLOGY REPORT  
 TO SUPPORT THE  
 FALCON RIDGE NORTH  
 TENTATIVE MAP  
 FIGURE 1

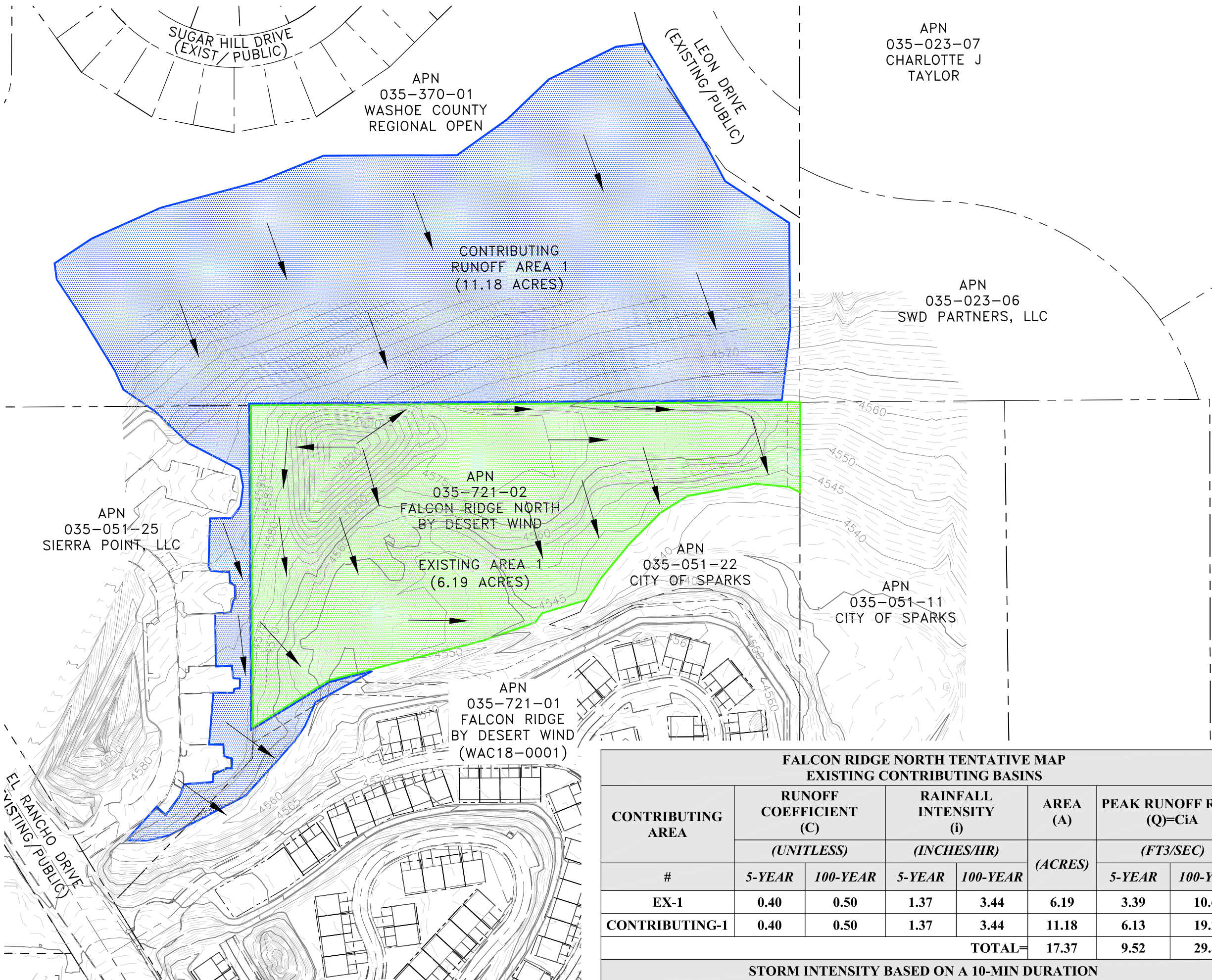
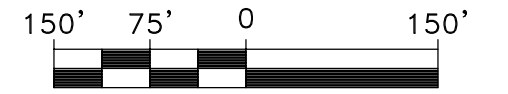

**LEGEND**

- PROJECT BOUNDARY
- (e)CONTOURS
- EXISTING RUNOFF DIRECTION
- EXISTING BASIN
- CONTRIBUTING RUNOFF AREA

| FALCON RIDGE NORTH TENTATIVE MAP<br>EXISTING CONTRIBUTING BASINS |                        |            |                        |             |                     |                                       |              |
|--|------------------------|------------|------------------------|-------------|---------------------|---------------------------------------|--------------|
| CONTRIBUTING AREA  | RUNOFF COEFFICIENT (C) |            | RAINFALL INTENSITY (i) |             | AREA (A)<br>(ACRES) | PEAK RUNOFF RATE (Q)=CiA<br>(FT3/SEC) |              |
|  | (UNITLESS)             | (UNITLESS) | (INCHES/HR)            | (INCHES/HR) |                     | 5-YEAR                                | 100-YEAR     |
| #  | 5-YEAR                 | 100-YEAR   | 5-YEAR                 | 100-YEAR    |                     | 5-YEAR                                | 100-YEAR     |
| EX-1   | 0.40                   | 0.50       | 1.37                   | 3.44        | 6.19                | 3.39                                  | 10.65        |
| CONTRIBUTING-1   | 0.40                   | 0.50       | 1.37                   | 3.44        | 11.18               | 6.13                                  | 19.23        |
| <b>TOTAL=</b>  |                        |            |                        |             | <b>17.37</b>        | <b>9.52</b>                           | <b>29.88</b> |
| STORM INTENSITY BASED ON A 10-MIN DURATION                       |                        |            |                        |             |                     |                                       |              |

PRELIMINARY  
HYDROLOGY REPORT  
TO SUPPORT THE  
FALCON RIDGE NORTH  
TENTATIVE MAP

EXISTING DRAINAGE BASINS  
FIGURE 2

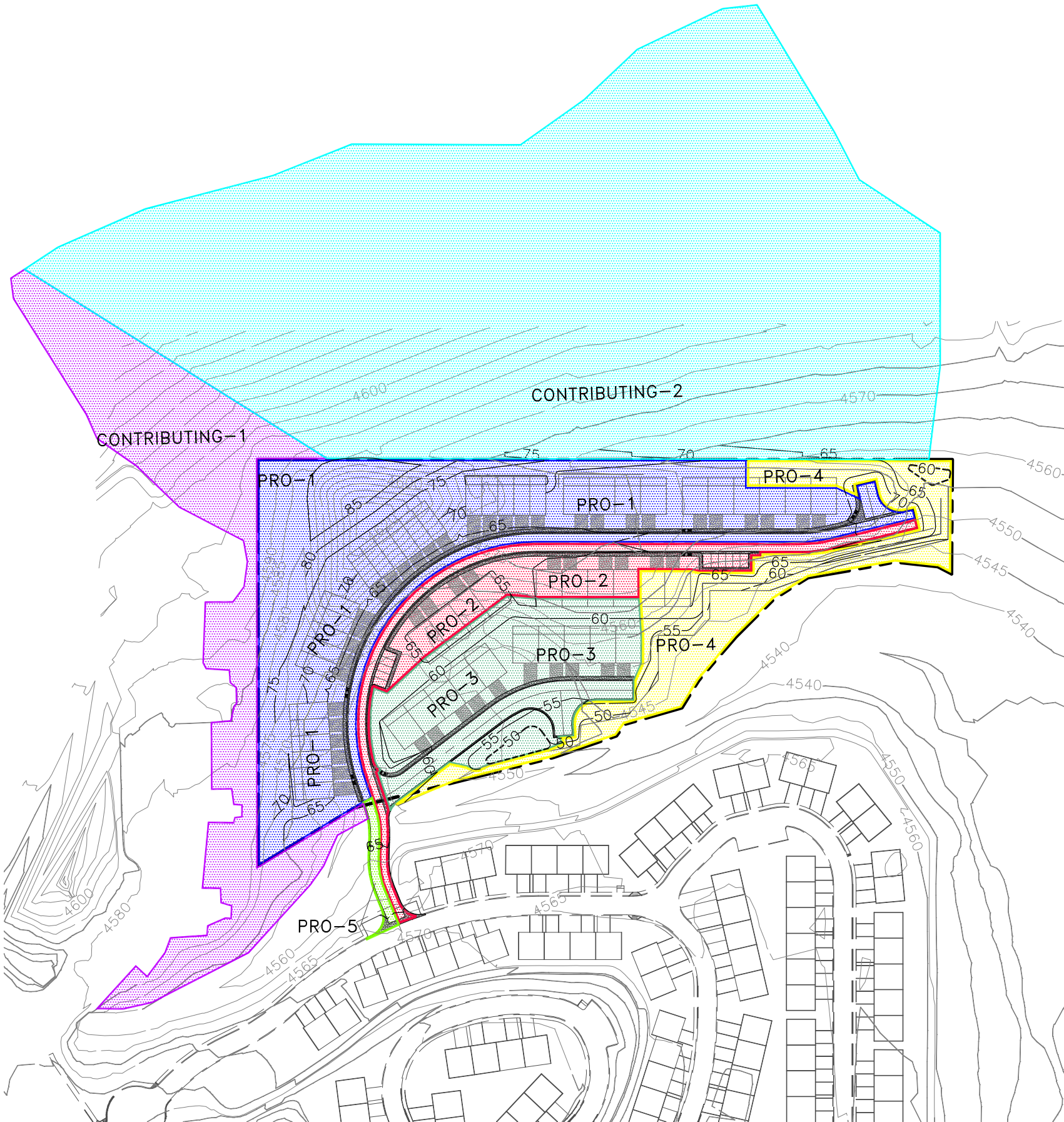
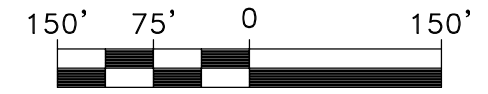

| FALCON RIDGE NORTH TENTATIVE MAP<br>PROPOSED CONTRIBUTING BASINS |                        |          |                        |          |                     |                                       |          |
|--|------------------------|----------|------------------------|----------|---------------------|---------------------------------------|----------|
| CONTRIBUTING AREA  | RUNOFF COEFFICIENT (C) |          | RAINFALL INTENSITY (i) |          | AREA (A)<br>(ACRES) | PEAK RUNOFF RATE (Q)=CiA<br>(FT3/SEC) |          |
|  | (UNITLESS)             |          | (INCHES/HR)            |          |                     | 5-YEAR                                | 100-YEAR |
| #  | 5-YEAR                 | 100-YEAR | 5-YEAR                 | 100-YEAR |                     | 5-YEAR                                | 100-YEAR |
| PRO-1  | 0.70                   | 0.75     | 1.37                   | 3.44     | 2.95                | 2.83                                  | 7.61     |
| PRO-2  | 0.88                   | 0.93     | 1.37                   | 3.44     | 0.94                | 1.13                                  | 3.01     |
| PRO-3  | 0.88                   | 0.93     | 1.37                   | 3.44     | 1.25                | 1.51                                  | 4.00     |
| PRO-4  | 0.50                   | 0.55     | 1.37                   | 3.44     | 1.11                | 0.76                                  | 2.10     |
| PRO-5  | 0.85                   | 0.90     | 1.37                   | 3.44     | 0.05                | 0.06                                  | 0.15     |
| CONTRIBUTING-1   | 0.40                   | 0.50     | 1.37                   | 3.44     | 9.28                | 5.09                                  | 15.96    |
| CONTRIBUTING-2   | 0.40                   | 0.50     | 1.37                   | 3.44     | 1.90                | 1.04                                  | 3.27     |
| TOTAL=   |                        |          |                        |          | 17.48               | 12.41                                 | 36.10    |

**LEGEND**

- PROJECT BOUNDARY
- (e)CONTOURS
- PROPOSED CONTOURS
- PROPOSED BASIN
- CONTRIBUTING BASIN

PRELIMINARY  
HYDROLOGY REPORT  
TO SUPPORT THE  
FALCON RIDGE NORTH  
TENTATIVE MAP

PROPOSED DRAINAGE BASINS  
FIGURE 3



Geotechnical & Environmental Engineers & Geologists

520 EDISON WAY • RENO, NEVADA 89502 • (775) 856-5566  
FAX • (775) 856-6042  
www.pezonella.com

December 27, 2005  
Job No. 5334.01-N

Falcon Ridge Townhouses, LLC  
401 Dayton Valley Road, Suite D  
Dayton, Nevada 89403

Attention: Mr. Gary Hill

Geotechnical Engineering Services  
Proposed Falcon Ridge Townhouses  
El Rancho Boulevard  
Washoe County, Nevada

### Introduction

This report presents results of the geotechnical engineering services our firm provided for the proposed Falcon Ridge Townhouses to be located in Washoe County, Nevada. The 25.594-acre site is situated on the east side of El Rancho Boulevard, south of its intersection with Clear Acre Lane, and encompasses Washoe County Assessor's Parcel Number 035-051-26. We have not received architectural plans; however, we understand the proposed project will include construction of isolated building pads for townhouse development to be serviced by community water, sewer and storm drain systems. The structures will be 1 to 2 stories, wood framed with slab-on-grade and/or joist supported floors, and will be supported with shallow conventional spread foundations. Associated asphaltic concrete surfaced roadways and parking areas will complete project development.

We have not received structural information; however, we anticipate that foundation loads will be normal (relatively light) for the type of construction proposed, that foundations will bottom at least 24 inches below lowest exterior ground surface and that structural design will follow criteria outlined in the 2003 edition of the International Building Code.

Based on grading information prepared by Jeff Codega Planning/Design, Inc., we understand earthwork necessary to attain rough pad grades and proper site drainage will result in cuts and fills up to approximately 30 feet. Depth of utility trench excavation is unknown. We further understand that any proposed slopes will be constructed at maximum slope inclinations of two horizontal to one vertical (2:1) or flatter, that earth retaining structures are proposed, and that any underground utilities existing within proposed structural areas will be relocated.

The scope of our work is to provide site preparation and earthwork specifications for mass grading operations and public improvements. Once design parameters, such as building locations, finish floor elevations, structural loads and finish grading information has been established, a detailed geotechnical investigation report should be performed.

This report is preliminary and geotechnical in nature and not intended to identify other site constraints such as environmental hazards, wetlands determinations and/or the potential presence of buried utilities. Additionally, recommendations included in this report are specific to mass grading operations within the limits of the property and, as such, are not intended for off-site development.

To aid in our work, we reviewed the results of a preliminary geotechnical investigation dated December 14, 2004, our firm prepared in evaluation of the proposed development (Job No. 5334.01-A).

#### Field Exploration and Laboratory Testing

To provide an overview of the subsurface conditions, we drilled 10 test borings with truck mounted (CME 55) hollow-stem auger equipment to depths of 15 to 30 feet below the existing ground surface. The boring locations, determined in the field using pace and compass and based on the referenced civil plans, are depicted (approximate locations) on Plate 1. No greater accuracy is implied.

Our field geologist logged and visually classified the materials encountered. Relatively undisturbed samples were collected from the test borings in a split spoon sampler utilizing a 140-pound hammer with a 30-inch drop. The blows per foot required to advance the sampler were converted and recorded (Standard Penetration Test). Logs of the test borings are presented on Plates 2 through 9. The materials are classified in accordance with the Unified Soil Classification System and the Rock Classification and Weathering Criteria Chart which are explained on Plates 10 and 11, respectively.

The samples were returned to our laboratory and reviewed by our staff engineer to confirm their field classifications, to select representative samples for laboratory testing and to determine engineering design parameters. Results of "in-situ" moisture content and dry density determinations, particle size analysis, Atterberg Limits, Expansion Index, and Resistance Value determinations are presented on the logs and on Plates 12 through 18. Additional tests, Resistivity, pH and SO<sub>4</sub>, were performed by an independent laboratory on selected samples to evaluate corrosion potential and are available on file.

Any proposed development outside the limits of our investigation or any conceptual changes to project development, such as grade changes, may require additional subsurface exploration, laboratory testing and engineering analysis.

### Site, Soil and Geologic Conditions

The site is bounded by El Rancho Boulevard to the west, Sierra Point Apartments, Phase II and undeveloped land to the north, residential development to the south and undeveloped property to the east. At the time of our investigation, the property was undeveloped with the exception of a single family residence located in the northern portion of the site. The surface slopes moderately downward from the northwest to the southeast and is covered by gravel and cobbles and medium dense sagebrush and weeds with trees located along the drainage areas. Outcrops of bedrock material were evident, which create relatively high areas of relief and a drainage system containing free water traverses the site in a northwest to southeast direction.

Based on geologic mapping completed by H. F. Bonham Jr. and E. C. Bingler (Nevada Bureau of Mines and Geology, *Reno Folio*, Geologic Map, 1973), the materials underlying the site are composed of Tertiary age Alta Formation (Ta). These sediments are described as consisting of dark brown pyroxene andesite flows, flow breccia, and laharc breccia. Commonly altered to tan rock composed of quartz, sericite, and clay minerals or propylitized to gray green rock containing chlorite, calcite, albite, epidote, and clay minerals.

Based on soil mapping by the U.S. Department of Agriculture, Soil Conservation Service (*Soil Survey of Washoe County, Nevada, South Part*, Sheet No. 22, 1980), the site is underlain by the following units:

Manogue cobbly clay, 2 to 8 percent slopes (# 190): This deep to very deep, well drained soil is on uplands and is formed in localized alluvium and colluvium derived dominantly from volcanic rocks. Typically, 10 to 25 percent of the surface is covered with cobbles and pebbles. The surface layer is a dark brown, cobbly clay about 2 inches thick. The subsoil is a brown clay about 61 inches thick and weathered bedrock is at a depth of 63 inches. Depth to weathered bedrock ranges from 40 to 70 inches. Permeability is described as very slow, available water capacity is high, effective rooting depth is 40 inches or more, runoff is medium and the hazard of water erosion and soil blowing is slight. The main limitations associated with the use of this soil for urban development, as described by the Soil Conservation Service, are the high shrink-swell potential associated with the clay soils, the very slow permeable subsoil which can restrict septic tank absorption fields and for roadways, the low load-bearing strength and high clay content.

Manogue cobbly clay, 8 to 15 percent slopes (# 191): This deep and very deep, well drained soil is on uplands and is formed in localized alluvium and colluvium derived dominantly from volcanic rocks. Typically, 10 to 25 percent of the surface is covered with cobbles and pebbles. The surface layer is a dark brown, cobbly clay about 3 inches thick. The subsoil is a brown clay about 60 inches thick and weathered bedrock is at a depth of 63 inches. Depth to weathered bedrock ranges from 40 to 70 inches. Permeability is described as very slow, available water capacity is high, effective rooting depth is 40 inches or more, runoff is medium, the hazard of water erosion is slight and the hazard of soil blowing is slight. Limitations associated with the use of this unit for urban development, as described by the Soil Conservation Service, are the high shrink-swell potential associated with the high clay content, the very slowly permeable subsoil (leachfields) and the low load-bearing strength (roadways).

Reywat extremely stony loam, 15 to 30 percent slopes (# 861): This shallow, well drained soil is on uplands and is formed in residuum of basic igneous rocks. Typically, 35 to 50 percent of the surface is covered with cobbles. The surface layer is a brown, very cobbly, sandy loam about 6 inches thick. The subsoil is a brown, very gravelly, clay loam about 12 inches thick. Bedrock is at a depth of 18 inches. Depth to bedrock ranges from 10 to 20 inches. Permeability is moderately slow; available water capacity is very low; effective rooting depth is 10 to 20 inches; runoff is medium and the hazard of water erosion and soil blowing is slight. Limitations associated with the use of this unit, as described by the Soil Conservation Service, are the shallowness of soil over bedrock, which may require heavy equipment to cut through, and the soil above the bedrock is too thin to permit conventional design of absorption fields.

Reywat-Rock outcrop complex, 15 to 50 percent slopes (# 863): This moderately deep, well drained unit is on pediments and river terraces and is formed in alluvium derived from rock sources. It is described as consisting of a grayish brown, stony, sandy loam surface to about 4 inches with a subsoil of pale brown and light yellowish brown clay approximately 20 inches thick. The substratum is strongly silica-cemented hardpan about 23 inches thick over weakly consolidated sediments. Depth to hardpan ranges from 20 to 40 inches. Permeability of the unit is described as slow, available water capacity is very low, effective rooting depth is 20 to 40 inches, runoff is slow, and the hazard of water erosion and soil blowing is slight. As defined by the Soil Conservation Service, the main limitations associated with this unit regarding urban development are the high clay content and associated high shrink-swell potential and low load-bearing strength for roadways.



Our exploration confirms, in general, the soil and geologic mapping, with the native soils consisting of loose (surface) to very dense, silty and clayey sand that contains gravel; stiff to hard clay that contains sand and gravel; loose (surface) to very dense silty gravel and andesite (Alta Formation) bedrock that exhibits varying degrees of alteration and weathering. Our investigation additionally reveals that a portion (northwest area adjacent to Sierra Point Apartments, Phase II) is overlain by fill material that consists of very dense, clayey sand and gravel that contains cobbles (Test Boring No. 8).

At the time of our investigation (June 1998), free water was encountered in one of our test borings (TB 8) at a non-stabilized depth of 13 feet below the existing ground surface. Generally, stabilized levels are higher than non-stabilized and we anticipate that, seasonally, this level will fluctuate.

Our investigation reveals that the native and fill materials exist in a relatively compact and/or firm density state, exhibit low to high potential for expansion and low to moderate supporting capability. Laboratory test results conducted through an independent laboratory indicate that the native materials exhibit a severe corrosion potential to portland cement and uncoated steel or metal.

Flood Hazard studies completed by the Federal Emergency Management Agency (FEMA), Community Panel Number 32031C2984 E, effective date September 30, 1994, indicate that the majority of the proposed development is located within Flood Hazard Zone X (unshaded); however, a small percentage along the drainage way is located within Flood Hazard Zone AE. Zone X (unshaded) are areas determined, based on the National Geodetic Vertical Datum of 1929, to be outside the 500-year floodplain whereas Zone AE are special flood hazard areas inundated by 100-year flooding with a based flood elevation determined to be 4445 feet.

Based on mapping completed by E. C. Bingler (Nevada Bureau of Mines and Geology, *Reno Folio*, Earthquake Hazards Map, 1974), no known fault traces are illustrated as crossing the project site.

## Conclusions

Based on the results of our geotechnical engineering services, understanding of project development, and knowledge of the areas, we conclude that, from a geotechnical engineering standpoint, the site is suitable for the intended use of the project. The primary concerns to be considered in the project design and construction are the **expansion potential** associated with the underlying materials (soil and bedrock), the presence of **bedrock**, the **steepness of slopes**, the **corrosion potential** associated with the underlying materials, the potential presence of **ground water, springs and/or seeps** and the potential for **flooding** to occur as delineated on the referenced FEMA map.

## Recommendations

We have the following recommendations for design and construction during mass grading operations and public improvement:

1. To minimize potential movement within exterior flatwork and pavement areas, materials with a potential for expansion should be removed (overexcavated) a sufficient depth to provide for at least 24 inches of approved, compacted structural fill below planned subgrade.

Similarly, materials with a Resistance Value of less than 30 within 6 inches of exterior flatwork and pavement subgrade should also be removed and replaced with approved compacted structural fill material.

The amount of lateral removal (beyond all exterior edges) should be equivalent to that vertically removed.

2. The ground surface should be permanently sloped (at least ½-percent for concrete, 2-percent for pavement, and 2 to 4 percent for soil) to drain away from any improvement so that water is not allowed to pond, and to restrict infiltration within exterior flatwork and flexible pavement sections. Landscaping should be limited and irrigation should be drip-type.
3. For trust block design, we recommend the use of a bearing pressure of 1500 pounds per square foot (psf). Resistance to lateral loads can be obtained from passive earth pressures and soil friction. We recommend the use of a coefficient of friction of 0.30 and a passive pressure of 300 pounds per cubic foot per foot of depth (equivalent fluid).

As previously mentioned, the native soils exhibit corrosion potential for portland cement concrete and uncoated steel or metal. Based on these results, we believe that adequate mitigation can be attained through the use of properly prepared and placed, corrosion resistant concrete (six sack Type II portland cement concrete with 20 percent flyash admixture); by maintaining a minimum (3-inch) concrete cover where reinforcing steel or other metal is in close proximity to native soils and, at the direction of the Manufacturer, by using special coating on reinforcing steel and metal.

4. All dedicated exterior flatwork should conform to standards provided by the governing agency, including section composition, supporting material thickness and any requirements for reinforcing steel.
5. Concrete mix proportions and construction techniques, including the addition of water and improper curing, can adversely affect the finished quality of the concrete and result in cracking and spalling of the slabs. We recommend that all placement and curing be performed in accordance with procedures outlined by the Portland Cement Association and American Concrete Institute. Special consideration should be given to concrete placed and cured during hot or cold weather conditions. Proper control joints and reinforcing mesh should be provided to minimize any damage resulting from shrinkage.
6. The Earthwork Contractor must comply with the *Safety and Health Regulations for Construction* as directed by the Occupational Safety and Health Act (OSHA Standards, Volume 11, Part 1926, Subpart P) while excavating and backfilling. The Earthwork Contractor is responsible for providing a Competent Person, as defined by the OSHA standards, to ensure excavation safety.

Clayey native materials (6-inch minus) shall be use as backfill to minimize the potential for subsurface water migration through the utility trenches. Backfill materials should be moisture conditioned to near optimum and compacted to at least 90 percent relative compaction. Lift thickness shall be restricted to 8 inches (loose) maximum, unless the Contractor can demonstrate his ability to achieve the required compaction uniformly throughout the entire layer placed.

For adequate corrosion mitigation, at the direction of the Manufacturer, special coverings should be provided where uncoated steel or metal is proposed.

7. Pavement sections can gain adequate support on the previously specified minimum section of approved compacted structural fill material.

Based on our understanding of project development (142 townhouses), we believe that a minimum section consisting of 3 inches of Type 2 or 3 asphaltic concrete over 6 inches of Type 2, Class B aggregate base underlain by the previously specified minimum section of approved subbase is adequate.

In preparation for placement of the pavement section, the Earthwork Contractor shall ensure that proposed subgrade materials have been observed and/or tested by the Geotechnical Engineer (or his representative in the field) to document conformance with the Resistance Value requirements. Generally, at least the upper 6 inches of subgrade should be scarified, moisture conditioned to near optimum and compacted to at least 95 percent relative compaction. Subsequently, aggregate base materials should be placed in maximum 8-inch (loose) lifts and compacted to at least 95 percent relative compaction. All subgrades and final grades should be rolled to provide a uniform surface which is smooth, firm, and non-yielding.

Aggregates should conform to the requirements contained in the latest edition of the *Standard Specifications for Public Works Construction*.

A bituminous concrete mix design, specific for the intended use, should be submitted for approval prior to paving. During paving, the bituminous mixture should be sampled and tested by the Geotechnical Engineer to ensure material quality and compaction. Periodic crack sealing and surface sealing must be implemented to increase service life of the pavement.

8. Consideration should be given to reviewing all plans and specifications for conformance with this geotechnical report and for approval by the Geotechnical Engineer prior to submitting to the governing agencies or for bidding purposes.

The recommendations presented in this report are based on the preliminary nature of our report, and assumption that sufficient field inspection and construction review will be provided during all phases of construction. Prior to construction, a pre-job conference should be scheduled to include, but not be limited to, the Owner, Architect, Civil Engineer, General Contractor, Earthwork and Materials Sub-Contractors, Building Official and Geotechnical Engineer. The recommendations presented in this report should be reviewed by all parties to discuss applicable specifications and testing requirements. At this time, any applicable material quality and mix design reports should be submitted for approval by the Geotechnical Engineer.

Falcon Ridge Townhouses, LLC  
Geotechnical Engineering Services  
Proposed Falcon Ridge Townhouses  
El Rancho Boulevard  
Washoe County, Nevada  
December 27, 2005 - Page 9

**Pezonella Associates, Inc.**

We should provide on-site observations and testing during site preparation and grading, excavation, fill placement and paving. These observations would allow us to document that the soil conditions are as anticipated, and that the Contractor's work is in conformance with the intent of our recommendations and the approved plans and specifications.

We appreciate having been selected to perform these services and trust that the results will fulfill project requirements at this time; however, if you, or any of your design consultants, have any questions, please contact us.

Respectfully,

PEZONELLA ASSOCIATES, INC.



12-27-05

Handwritten signature of Chris D. Betts in blue ink.

Chris D. Betts  
Engineer Geologist

Handwritten signature of Raymond M. Pezonella in blue ink.

Raymond M. Pezonella  
Civil Engineer - 4186

Enclosures: Plate 1 through 19  
Specifications for Site Preparation and Earthwork

Submittal: Original and two copies

cc: Jeff Codega Planning/Design, Inc. (Attention: Mr. Tom Tescher, PE)

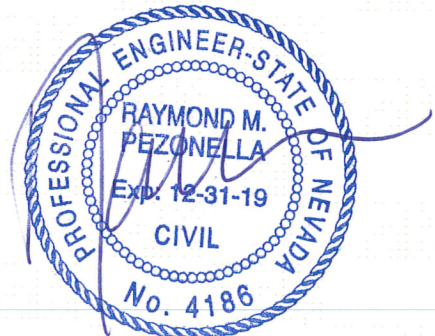

8-9-19

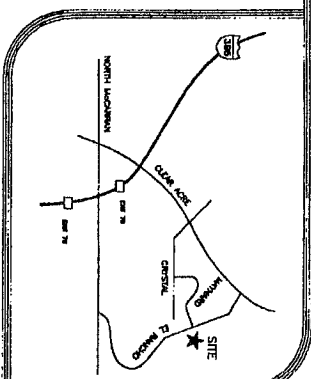

VICINITY MAP

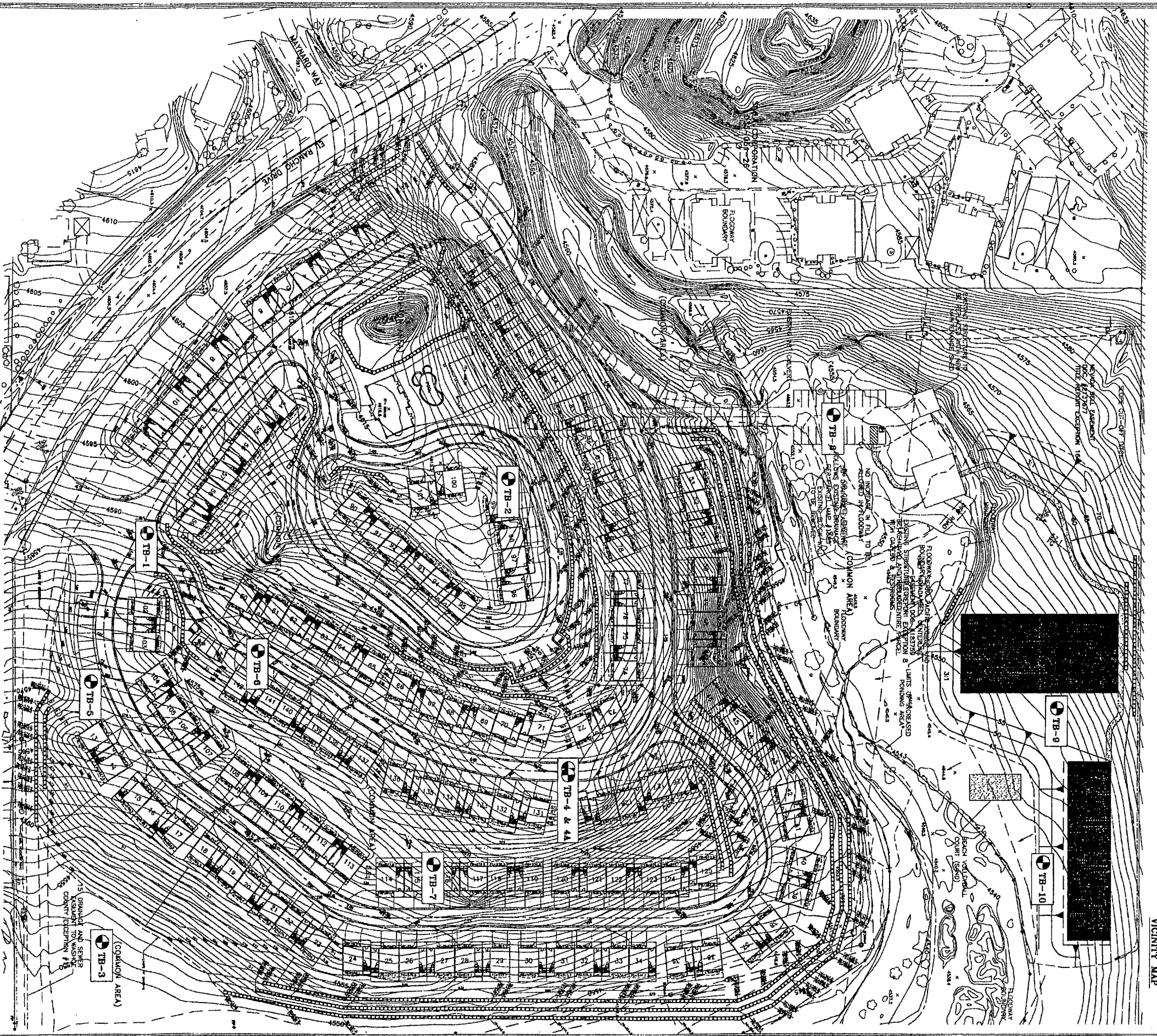

● = Boring Location

Layout from Grading Plan furnished by Jeff Codega Planning and Design, Inc.

|              |   |   |   |   |
|--------------|---|---|---|---|
| RTS          | 1 | 2 | 3 | 4 |
| 5394.01-N    | 1 | 2 | 3 | 4 |
| 12-28-05     | 1 | 2 | 3 | 4 |
| NOT TO SCALE | 1 | 2 | 3 | 4 |

PLAT

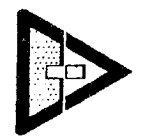

**Pezonella Associates, Inc**

Consulting Engineers  
520 Edison Way Reno, Nevada 89502  
PHONE (775) 856-5566 FAX (775) 856-6042

**FALCON RIDGE TOWNHOUSES**  
**WASHOE COUNTY, NEVADA**

# LOG OF BORING 1

Equipment CME 55 Hollow Stem Auger

Elevation 4588 Date 06-04-98

| Laboratory Tests<br>and<br>(Other Information)                            | Driving<br>Resistance<br>Blows/Ft. | Moisture<br>Content (%) | Dry<br>Density (pcf) | Depth (ft)<br>Sample |  |
|---|------------------------------------|-------------------------|----------------------|----------------------|--|
| * Plasticity Chart<br>(See Plate 14)<br>Expansion Index<br>(See Plate 17) | 9                                  |                         |                      | *                    |  |
|   | 20                                 |                         |                      | **                   |  |
| ** Plasticity Chart<br>(See Plate 15)                                     |                                    | 24.7                    | 89                   | 5                    |  |
|   | 37                                 |                         |                      | 10                   |  |
|   | 66                                 |                         |                      | 15                   |  |
|   | 50/5"                              |                         |                      |                      | <p>sampler refusal at 15.0 feet</p> <p>No Free Water Encountered</p> |

## Elevation Reference:

Elevations taken from topographical information provided by Jeff Codega, Planning/Design, Inc.

|   |  |                    |
|---|--|--------------------|
| Job No. 5334.01-N   | BORING LOG   | COB/appr./12-28-05 |
| <b>Pezonella Associates, Inc</b><br><small>Consulting Engineers<br/>                     520 Edison Way Reno, Nevada 89502<br/>                     PHONE (775) 856-6666 FAX (775) 856-6042</small> | <b>FALCON RIDGE TOWNHOUSES</b><br><b>WASHOE COUNTY, NEVADA</b> | Plate No. 2        |

# LOG OF BORING 2

Equipment CME 55 Hollow Stem Auger

Elevation 4609 Date 06-04-98

| Laboratory Tests<br>and<br>(Other Information)                                    | Driving<br>Resistance<br>Blows/Ft. | Moisture<br>Content (%) | Dry<br>Density (pcf) | Depth<br>(ft)<br>Sample |  |
|---|------------------------------------|-------------------------|----------------------|-------------------------|--|
|   | 49                                 |                         |                      | 0                       | <b>BROWN SILTY SAND (SM)</b><br>medium dense, dry with roots   |
|   | 74                                 |                         |                      | 5                       | <b>BROWN TO WHITE ANDESITE (Alta Formation)</b><br>moderately fractured, moderately hard, moderately<br>strong and moderately weathered<br>sampler refusal at 4.0 feet |
|   | 60/6"                              |                         |                      | 10                      | sampler refusal at 9.0 feet  |
|   | 59/6"                              |                         |                      | 15                      | sampler refusal at 13.5 feet   |
| * Particle Size<br>Distribution Report<br>with Atterberg Limits<br>(See Plate 12) | 50/4"                              |                         |                      | 20                      | sampler refusal at 19.0 feet   |
|   | 50/5"                              |                         |                      | 25                      | sampler refusal at 24.0 feet   |
|   | 50/4"                              |                         |                      | 30                      | sampler refusal at 29.5 feet   |

No Free Water Encountered

Elevation Reference:

See log of Boring 1

|   |  |                     |
|---|--|---------------------|
| Job No. 5334.01-N   | BORING LOG   | CMB /appr./12-28-05 |
|  <b>Pezonella Associates, Inc</b><br>Consulting Engineers<br>520 Edison Way Reno, Nevada 89502<br>PHONE (775) 856-5568 FAX (775) 856-8042 | <b>FALCON RIDGE TOWNHOUSES</b><br><b>WASHOE COUNTY, NEVADA</b> | Plate No. 3         |



## LOG OF BORING 3

Equipment CME 55 Hollow Stem Auger

Elevation 4552 Date 06-04-98

| Laboratory Tests and<br>(Other Information) | Driving Resistance<br>Blows/Ft. | Moisture<br>Content (%) | Dry<br>Density (pcf) | Depth (ft)<br>Sample |  |
|---|---------------------------------|-------------------------|----------------------|----------------------|--|
| * Plasticity Chart<br>(See Plate 16)        | 9                               | 14.9                    | 115                  | 0                    |  |
|   | 20                              |                         |                      | 5                    |  |
|   | 37                              |                         |                      | 10                   |  |
|   | 66                              |                         |                      | 15                   |  |
|   | 50/5"                           |                         |                      | 15                   |  |

### Elevation Reference:

See Log Of Boring 1

Job No. 5334.01-N

BORING LOG

COB/appr./12-28-05

**Pezonella Associates, Inc**  
 Consulting Engineers  
 520 Edison Way Reno, Nevada 89502  
 PHONE (775) 856-6566 FAX (775) 856-6042

**FALCON RIDGE TOWNHOUSES**  
**WASHOE COUNTY, NEVADA**

Plate No. 4

# LOG OF BORING 4

Equipment CME 55 Hollow Stem Auger

Elevation 4592 Date 06-04-98

| Laboratory Tests and<br>(Other Information) | Driving Resistance<br>Blows/Ft. | Moisture Content (%) | Dry Density (pcf) | Depth (ft)<br>Sample |  |
|---|---------------------------------|----------------------|-------------------|----------------------|--|
|   | 43                              |                      |                   | 0                    | <p><b>BROWN SILTY SAND (SM)</b> medium dense, dry with roots<br/> <b>BROWN CLAY (CH)</b> with gravel<br/>                     very stiff, dry with roots</p> <p><b>ORANGE ANDESITE (Alta Formation)</b><br/>                     moderately fractured, moderately hard, moderately<br/>                     strong and moderately weathered<br/>                     sampler refusal at 4.0 feet</p> <p>sampler refusal at 9.0 feet</p> <p>sampler refusal at 14.0 feet</p> <p>sampler refusal at 19.0 feet</p> <p style="text-align: center;">No Free Water Encountered</p> |
|   | 27/3"                           |                      |                   | 5                    |  |
|   | 50/2"                           |                      |                   | 10                   |  |
|   | 50/2"                           |                      |                   | 15                   |  |
|   | 25/0"                           |                      |                   | 20                   |  |

## Elevation Reference:

See Log Of Boring 1

Job No. 5334.01-N

BORING LOG

CMB /appr./12-28-05

 **Pezonella Associates, Inc**  
 Consulting Engineers  
 520 Edison Way Reno, Nevada 89502  
 PHONE (775) 856-5566 FAX (775) 856-5042

**FALCON RIDGE TOWNHOUSES**  
**WASHOE COUNTY, NEVADA**

Plate No. 5

# LOG OF BORING 4A

Equipment CME 55 Hollow Stem Auger

Elevation 4592 Date 06-05-98

| Laboratory Tests<br>and<br>(Other Information) | Driving<br>Resistance<br>Blows/Ft. | Moisture<br>Content (%) | Dry<br>Density (pcf) | Depth (ft)<br>Sample |  |
|--|------------------------------------|-------------------------|----------------------|----------------------|--|
|  | 43                                 |                         |                      |                      | <div style="display: flex; align-items: center;">  <div style="margin-left: 10px;"> <p><b>BROWN SILTY GRAVEL (GM)</b><br/>dense, dry</p> <p>becoming very dense below 3.0 feet</p> <p><b>ORANGE ANDESITE (Alta Formation)</b><br/>moderately fractured, moderately hard, moderately strong and moderately weathered</p> <p>No Free Water Encountered</p> </div> </div> |
|  | 27/3"                              |                         |                      | 5                    |  |
|  | 50/2"                              |                         |                      | 10                   |  |
|  | 50/2"                              |                         |                      | 15                   |  |
|  | 25/0"                              |                         |                      | 20                   |  |
|  |                                    |                         |                      | 25                   |  |

## Elevation Reference:

See Log Of Boring 1

|   |  |                    |
|---|--|--------------------|
| Job No. 5334.01-N   | BORING LOG   | CDB/appr./12-28-05 |
|  <b>Pezonella Associates, Inc</b><br>Consulting Engineers<br>520 Edison Way Reno, Nevada 89502<br>PHONE (775) 856-5566 FAX (775) 856-6042 | <b>FALCON RIDGE TOWNHOUSES</b><br><b>WASHOE COUNTY, NEVADA</b> | Plate No. 6        |

| Laboratory Tests<br>and<br>(Other Information) | Driving<br>Resistance<br>Blows/Ft. | Moisture<br>Content (%) | Dry<br>Density (pcf) | LOG OF BORING 5                           |  |
|--|------------------------------------|-------------------------|----------------------|---|--|
|  |                                    |                         |                      | Equipment <u>CME 55 Hollow Stem Auger</u> | Elevation <u>4572</u> Date <u>06-05-98</u>   |
|  | 17                                 |                         |                      |   | BROWN SILTY GRAVEL (GM) loose, dry with roots<br>BROWN CLAY (CH)<br>hard, dry<br><br>color change to orange-brown below 4.0 feet<br>sampler refusal at 4.0 feet<br><br>with gravel below 9.0 feet<br>sampler refusal at 9.0 feet |
|  | 27/5"                              |                         |                      |   |  |
|  | 50/3"                              |                         |                      |   |  |
|  | 36                                 |                         |                      |   | No Free Water Encountered  |

**Elevation Reference:**

See Log Of Boring 1

**LOG OF BORING 6**

Equipment CME 55 Hollow Stem Auger

Elevation 4582 Date 06-17-98

|  |    |  |  |  |  |
|--|----|--|--|--|--|
|  | 11 |  |  |  | DARK BROWN CLAYEY SAND (SC) with gravel<br>medium dense, moist with roots<br><br>ORANGE-BROWN CLAY (CH) with gravel<br>very stiff, moist<br><br>BROWN-YELLOW ANDESITE (Alta Formation) moderately<br>fractured, moderately hard, moderately strong and<br>moderately weathered<br><br>with gravel and becoming dense below 13.0 feet |
|  | 23 |  |  |  |  |
|  | 43 |  |  |  |  |
|  | 63 |  |  |  | No Free Water Encountered  |
|  | 37 |  |  |  |  |

**Elevation Reference:**

See Log Of Boring 1

Job No. 5334.01-N

BORING LOG

CDB/appr./12-28-05

 **Pezonella Associates, Inc**  
 Consulting Engineers  
 520 Edison Way Reno, Nevada 89502  
 PHONE (775) 856-5566 FAX (775) 856-6042

FALCON RIDGE TOWNHOUSES  
 WASHOE COUNTY, NEVADA

Plate No. 7

## LOG OF BORING 7

Equipment CME 55 Hollow Stem Auger

Elevation 4574 Date 06-17-98

| Laboratory Tests and<br>(Other Information) | Driving Resistance<br>Blows/Ft. | Moisture Content (%) | Dry Density (pcf) | Depth (ft)<br>Sample |   |
|---|---------------------------------|----------------------|-------------------|----------------------|---|
|   | 21                              |                      |                   | 0                    | <b>DARK BROWN CLAYEY SAND (SC) with gravel</b><br>medium dense, moist with roots to 1.0 feet                              |
|   | 19                              |                      |                   | 5                    | <b>BROWN CLAY (CH) with sand and gravel</b><br>stiff, moist   |
|   | 33                              |                      |                   | 10                   | Increasing sand content below 9.0 feet  |
|   | 77                              |                      |                   | 15                   | <b>ORANGE ANDESITE (Alta Formation) moderately fractured, moderately hard, moderately strong and moderately weathered</b> |

No Free Water Encountered

### Elevation Reference:

See Log Of Boring 1

## LOG OF BORING 8

Equipment CME 55 Hollow Stem Auger

Elevation 4559 Date 06-17-98

| Laboratory Tests and<br>(Other Information)  | Driving Resistance<br>Blows/Ft. | Moisture Content (%) | Dry Density (pcf) | Depth (ft)<br>Sample |  |
|--|---------------------------------|----------------------|-------------------|----------------------|--|
| * Particle Size Distribution Report with Atterberg Limits (See Plate 13)<br>R-Value Test Report (See Plate 18) | 27/6"                           |                      |                   | 0                    | <b>BROWN CLAYEY SAND (SC) with gravel</b><br>very dense, moist with roots to 1.0 feet<br>sampler refusal at 0.5 feet<br>color change to dark brown below 1.0 feet  |
|  | 30/6"                           |                      |                   | 5                    | sampler refusal at 3.5 feet<br><b>BROWN CLAYEY GRAVEL (GC) with sand and cobbles</b><br>very dense, wet  |
|  | 30/4"                           |                      |                   | 10                   | <b>ORANGE-BROWN CLAYEY SAND (SC) with gravel</b><br>very dense, moist<br>sampler refusal at 8.5 feet   |
|  | 24                              |                      |                   | 15                   | water level (13.0 feet). Not stabilized 06-17-98<br>color change to light tan and becoming medium dense and saturated below 13.0 feet<br>No Free Water Encountered |

↑  
FILL  
↓

### Elevation Reference:

See Log Of Boring 1

|   |  |                     |
|---|--|---------------------|
| Job No. 5334.01-N   | <b>BORING LOG</b>  | CMB /appr./12-28-05 |
|  <b>Pezonella Associates, Inc</b><br>Consulting Engineers<br>520 Edison Way Reno, Nevada 89502<br>PHONE (775) 856-5666 FAX (775) 856-6042 | <b>FALCON RIDGE TOWNHOUSES</b><br><b>WASHOE COUNTY, NEVADA</b> | <b>Plate No. 8</b>  |

## LOG OF BORING 9

Equipment CME 55 Hollow Stem Auger

Elevation 4554 Date 06-17-98

| Laboratory Tests and<br>(Other Information) | Driving Resistance<br>Blows/Ft. | Moisture Content (%) | Dry Density (pcf) | Depth (ft)<br>Sample |
|---|---------------------------------|----------------------|-------------------|----------------------|
|   | 35                              |                      |                   |                      |
|   | 10<br>23                        |                      |                   |                      |
|   | 29                              |                      |                   |                      |
|   | 14                              |                      |                   |                      |

**BROWN SANDY CLAY (CH)**  
stiff, dry with roots to 1.0 feet

**LIGHT BROWN SILTY SAND (SM)**  
medium dense, dry

**ORANGE ANDESITE (Alta Formation)** moderately fractured, moderately hard, moderately strong and moderately weathered

No Free Water Encountered

### Elevation Reference:

See Log Of Boring 1

## LOG OF BORING 10

Equipment CME 55 Hollow Stem Auger

Elevation 4548 Date 06-17-98

|  |       |  |  |   |
|--|-------|--|--|---|
|  | 19    |  |  |   |
|  | 27/5" |  |  | <p><b>BROWN SILTY SAND (SM)</b> loose, dry</p> <p><b>BROWN SANDY CLAY (CH)</b> very stiff, moist</p> <p><b>ORANGE-BROWN CLAYEY SAND (SC)</b> very dense, moist</p> <p>sampler refusal at 4.5 feet</p> |
|  | 67/6" |  |  | <p>sampler refusal at 9.5 feet</p>  |
|  | 79    |  |  | No Free Water Encountered   |

### Elevation Reference:

See Log Of Boring 1

Job No. 5334.01-N

BORING LOG

CSB/appr./12-28-05

**Pezonella Associates, Inc**  
Consulting Engineers  
520 Edison Way Reno, Nevada 89502  
PHONE (775) 856-5566 FAX (775) 856-6042

**FALCON RIDGE TOWNHOUSES**  
**WASHOE COUNTY, NEVADA**

Plate No. 9

| MAJOR DIVISIONS  |   |                                       | TYPICAL NAMES  |   |
|--|---|---------------------------------------|--|---|
| COARSE GRAINED SOILS<br>MORE THAN HALF IS LARGER THAN #200 SIEVE | GRAVELS<br>MORE THAN HALF COURSE FRACTION IS LARGER THAN No. 4 SIEVE SIZE | CLEAN GRAVELS WITH LITTLE OR NO FINES | GW<br>   | WELL GRADED GRAVELS, GRAVEL-SAND MIXTURES               |
|  |   |                                       | GP<br>   | POORLY GRADED GRAVELS, GRAVEL-SAND MIXTURES             |
|  |   | GRAVELS WITH OVER 12% FINES           | GM<br>   | SILTY GRAVELS, POORLY GRADED GRAVEL-SAND SILT MIXTURES  |
|  |   |                                       | GC<br>   | CLAYEY GRAVELS, POORLY GRADED GRAVEL-SAND-CLAY MIXTURES |
|  | SANDS<br>MORE THAN HALF COURSE FRACTION IS SMALLER THAN No. 4 SIEVE SIZE  | CLEAN SANDS WITH LITTLE OR NO FINES   | SW<br>   | WELL GRADED SANDS, GRAVELLY SANDS                       |
|  |   |                                       | SP<br>   | POORLY GRADED SANDS, GRAVELLY SANDS                     |
|  |   | SANDS WITH OVER 12% FINES             | SM<br>   | SILTY SANDS, POORLY GRADED SAND-SILT MIXTURES           |
|  |   |                                       | SC<br>   | CLAYEY SANDS, POORLY GRADED SAND-CLAY MIXTURES          |
| FINE GRAINED SOILS<br>MORE THAN HALF IS SMALLER THAN #200 SIEVE  | SILTS AND CLAY<br>LIQUID LIMIT LESS THAN 50                               | ML<br>                                | INORGANIC SILTS AND VERY FINE SANDS, ROCK FLOUR, SILTY OR CLAYEY FINE SANDS OR CLAYEY SILTS WITH SLIGHT PLASTICITY |   |
|  |   | CL<br>                                | INORGANIC CLAYS OF LOW TO MEDIUM PLASTICITY, GRAVELLY CLAYS, SANDY CLAYS SILTY CLAYS, LEAN CLAYS                   |   |
|  |   | OL<br>                                | INORGANIC CLAYS AND ORGANIC SILTY CLAYS OF LOW PLASTICITY  |   |
|  | SILTS AND CLAYS<br>LIQUID LIMIT GREATER THAN 50                           | MH<br>                                | INORGANIC SILTS, MICACEOUS OR DIATOMACEOUS FINE SANDY OR SILTY SOILS, ELASTIC SILTS                                |   |
|  |   | CH<br>                                | INORGANIC CLAYS OF HIGH PLASTICITY, FAT CLAYS  |   |
|  |   | OH<br>                                | ORGANIC CLAYS OF MEDIUM TO HIGH PLASTICITY, ORGANIC SILTS  |   |
| BEDROCK  |   |                                       | ANDESITE BEDROCK (ALTA FORMATION)  |   |

## UNIFIED SOIL CLASSIFICATION SYSTEM

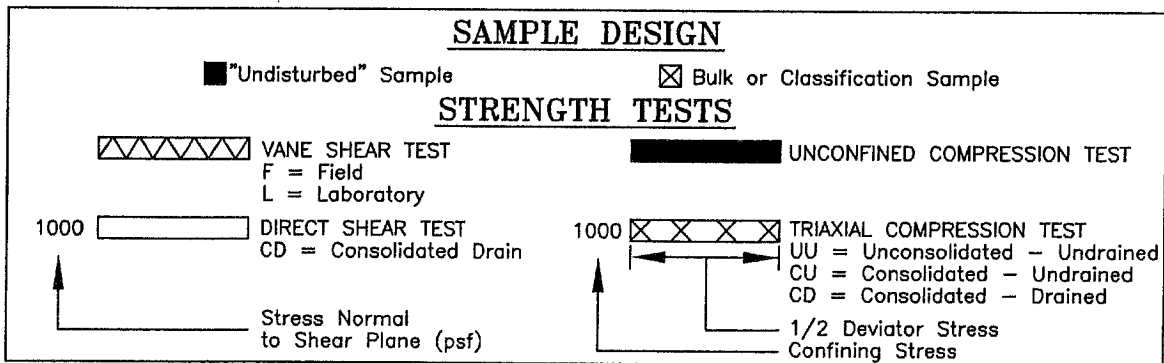

## KEY TO TEST DATA

Job No. 5334.01-N

FALCON RIDGE TOWNHOUSES /appr./12-28-05

**Pezonella Associates, Inc**  
 Consulting Engineers  
 520 Edison Way Reno, Nevada 89502  
 PHONE (775) 866-6666 FAX (775) 866-8042

**SOIL CLASSIFICATION CHART  
AND KEY TO TEST DATA**

Plate No. 10

**FRACTURING** - Fractures include joints, faults and shears. Joints are fractures (no relative movement of rock on either side) and can be regular or irregular and discontinuous. Faults or shears are fractures on which movement has taken place.

| Intensity            | Fracture Spacing (ft) |
|----------------------|-----------------------|
| Crushed              | Less than 0.05        |
| Intensely fractured  | 0.05 - 0.1            |
| Closely fractured    | 0.1 - 0.5             |
| Moderately fractured | 0.5 - 1.0             |
| Little fractured     | 1.0 - 4.0             |
| Massive              | Greater than 4.0      |

**HARDNESS** - Hardness and strength are in many ways interrelated and the meaning of the term depends on the use to which it is put. Hardness is evaluated with a pocket knife on an unfractured specimen. When equating mass hardness, the degree of fracturing should always be considered.

- A. Soft - reserved for plastic material only
- B. Low Hardness - can be gouged deeply or carved with a pocket knife
- C. Moderately Hard - can be readily scratched by a knife blade, scratch leaves heavy traces of dust and is readily visible after the powder has been blown away.
- D. Hard - can be scratched with difficulty, scratch produces little powder and is often faintly visible.
- E. Very Hard - cannot be scratched with pocket knife, leaves metallic streak.

**STRENGTH** - The strength of rock visually evaluated in the field is somewhat subjective in that it depends upon the observer's interpretation and of the response of unfractured specimens to hammer blows. Consistency between observers can be evaluated through laboratory test results.

- A. Plastic - material deforms with hammer blows without fracturing
- B. Friable - crumbles by rubbing with fingers.
- C. Moderately Strong - specimen will withstand few heavy hammer blows before breaking.
- D. Strong - Specimen will withstand a few heavy ringing hammer blows and usually yields large fragments.
- E. Very Strong - Rock will resist heavy ringing hammer blows and will yield with difficulty only dust and small flying fragments.

| WEATHERING -                           | DEEP  | MODERATE                               | LITTLE                                  | FRESH                           |
|--|---|--|---|---------------------------------|
| DECOMPOSITION                          | moderate to complete  | affects only slight change in minerals | no megascopic decomposition of minerals | unaffected by weathering agents |
| DISCOLORATION                          | deep and thorough   | moderate or localized and intense      | slight and intermittent or localized    | unaffected by weathering agents |
| FRACTURE CONDITION<br>Minerals Present | all fractures extensively coated with oxides, carbonates, or clay or silt | moderately coated                      | few stains on fracture surfaces         | unaffected by weathering agents |

**NOTE:** The physical and chemical disintegration and decomposition of rocks and minerals by natural processes such as oxidation reduction, hydration, solution, carbonation, and freezing and thawing.

Job No. 5334.01-N

**ROCK AND WEATHERING  
CLASSIFICATION CRITERIA**

CSG /appr./12-28-05

 **Pezonella  
Associates, Inc**  
Consulting Engineers  
520 Edison Way Reno, Nevada 89502  
PHONE (775) 856-5566 FAX (775) 856-8042

**FALCON RIDGE TOWNHOUSES  
WASHOE COUNTY, NEVADA**

Plate No. 11



# Particle Size Distribution Report

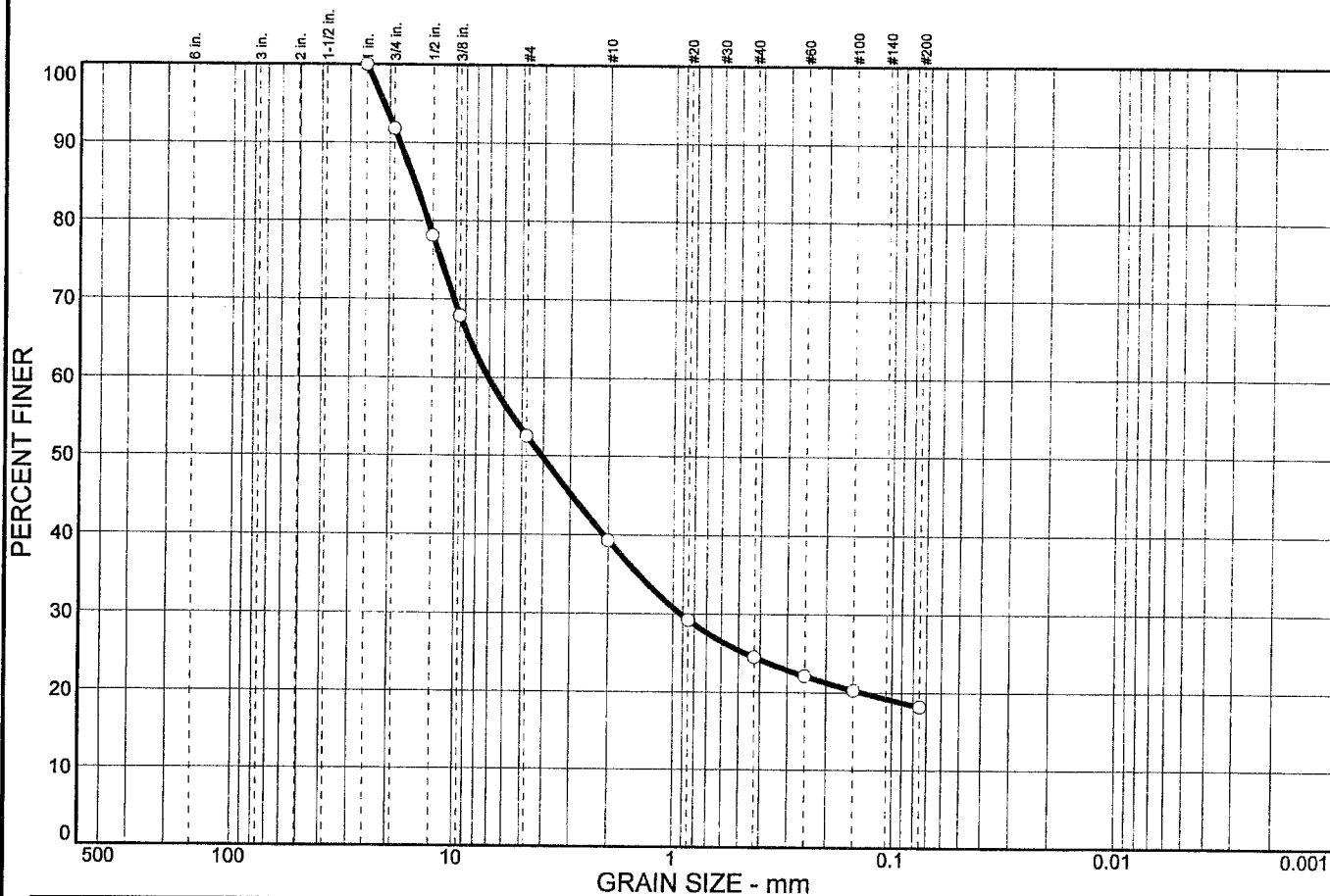

| % COBBLES | % GRAVEL |      | % SAND |        |      | % FINES |      |
|-----------|----------|------|--------|--------|------|---------|------|
|           | CRS.     | FINE | CRS.   | MEDIUM | FINE | SILT    | CLAY |
| 0.0       | 8.2      | 39.3 | 13.2   | 14.8   | 6.3  | 18.2    |      |

| SIEVE SIZE | PERCENT FINER | SPEC.* PERCENT | PASS? (X=NO) |
|------------|---------------|----------------|--------------|
| 1 in.      | 100.0         |                |              |
| 3/4 in.    | 91.8          |                |              |
| 1/2 in.    | 78.1          |                |              |
| 3/8 in.    | 67.9          |                |              |
| #4         | 52.5          |                |              |
| #10        | 39.3          |                |              |
| #20        | 29.2          |                |              |
| #40        | 24.5          |                |              |
| #60        | 22.1          |                |              |
| #100       | 20.3          |                |              |
| #200       | 18.2          |                |              |

**Material Description**

Brown to white Andesite bedrock

**Atterberg Limits**

PL=                      LL=                      PI=

**Coefficients**

D<sub>85</sub>= 15.4              D<sub>60</sub>= 7.09              D<sub>50</sub>= 4.08  
 D<sub>30</sub>= 0.926            D<sub>15</sub>=                      D<sub>10</sub>=  
 C<sub>u</sub>=                      C<sub>c</sub>=

**Classification**

USCS= Andesite                      AASHTO=

**Remarks**

Non-plastic material (will not roll)

\* (no specification provided)

Sample No.:  
Location:

Source of Sample: TB-2

Date: 06-30-98  
Elev./Depth: 18.0 to 18.5

**PEZONELLA  
ASSOCIATES, INC.  
Reno, Nevada**

Client:  
Project: Falcon Ridge Townhouses

Project No: 5334.01-N

Plate 12

# Particle Size Distribution Report

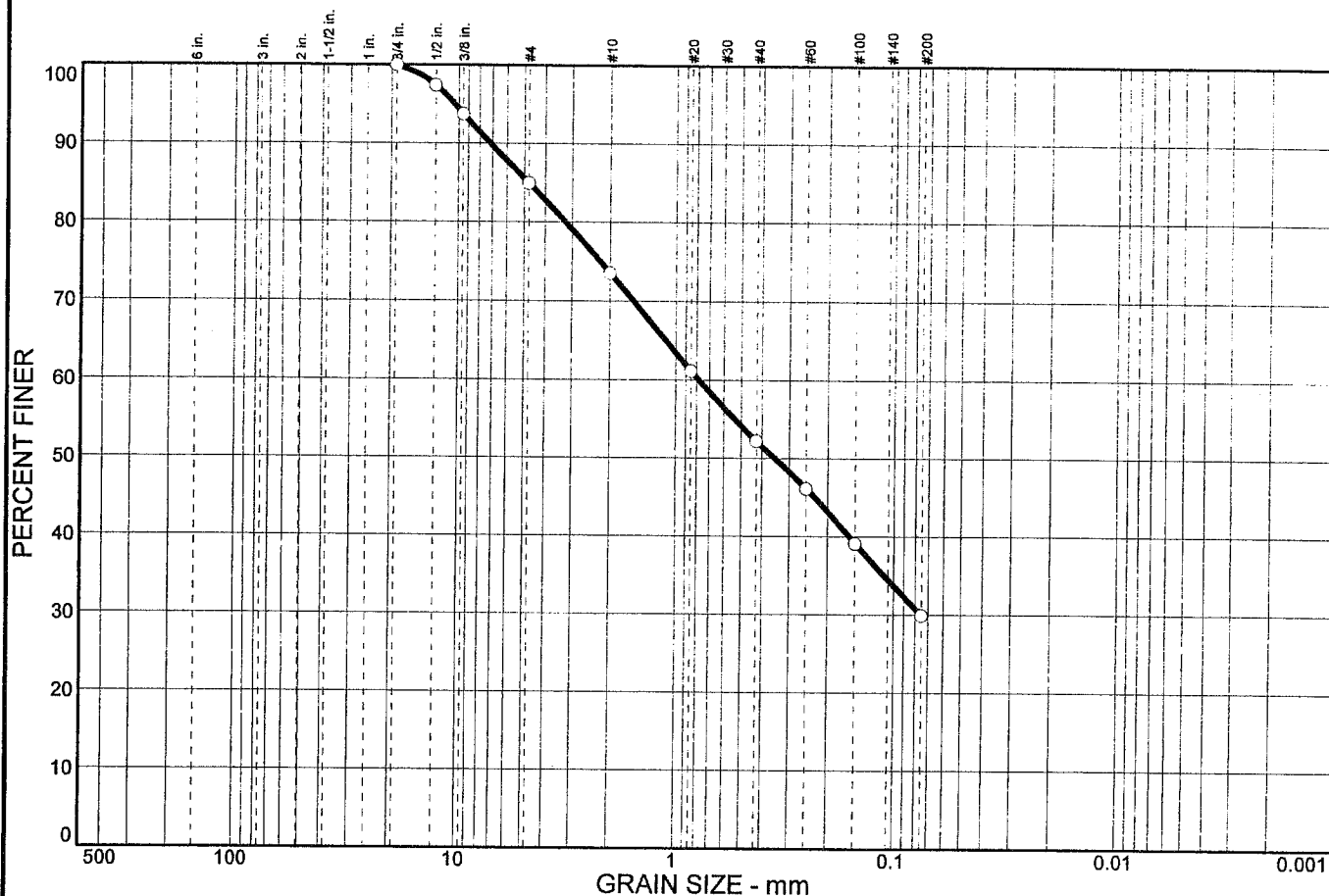

| % COBBLES | % GRAVEL |      | % SAND |        |      | % FINES |      |
|-----------|----------|------|--------|--------|------|---------|------|
|           | CRS.     | FINE | CRS.   | MEDIUM | FINE | SILT    | CLAY |
| 0.0       | 0.0      | 15.1 | 11.4   | 21.3   | 22.3 | 29.9    |      |

| SIEVE SIZE | PERCENT FINER | SPEC.* PERCENT | PASS? (X=NO) |
|------------|---------------|----------------|--------------|
| 3/4 in.    | 100.0         |                |              |
| 1/2 in.    | 97.4          |                |              |
| 3/8 in.    | 93.7          |                |              |
| #4         | 84.9          |                |              |
| #10        | 73.5          |                |              |
| #20        | 61.1          |                |              |
| #40        | 52.2          |                |              |
| #60        | 46.1          |                |              |
| #100       | 39.1          |                |              |
| #200       | 29.9          |                |              |

**Material Description**

Brown clayey sand (SC) with gravel

**Atterberg Limits**

PL= 17      LL= 30      PI= 13

**Coefficients**

D<sub>85</sub>= 4.79      D<sub>60</sub>= 0.785      D<sub>50</sub>= 0.350  
D<sub>30</sub>= 0.0756      D<sub>15</sub>=      D<sub>10</sub>=  
C<sub>u</sub>=      C<sub>c</sub>=

**Classification**

USCS= (SC)      AASHTO=

**Remarks**

\* (no specification provided)

Sample No.: 914  
Location:

Source of Sample: TB-8

Date: 06-09-98  
Elev./Depth: 0.0 to 4.0 feet

**PEZONELLA  
ASSOCIATES, INC.  
Reno, Nevada**

Client:  
Project: Falcon Ridge Townhouses

Project No: 5334.01-N

Plate 13

# LIQUID AND PLASTIC LIMITS TEST REPORT

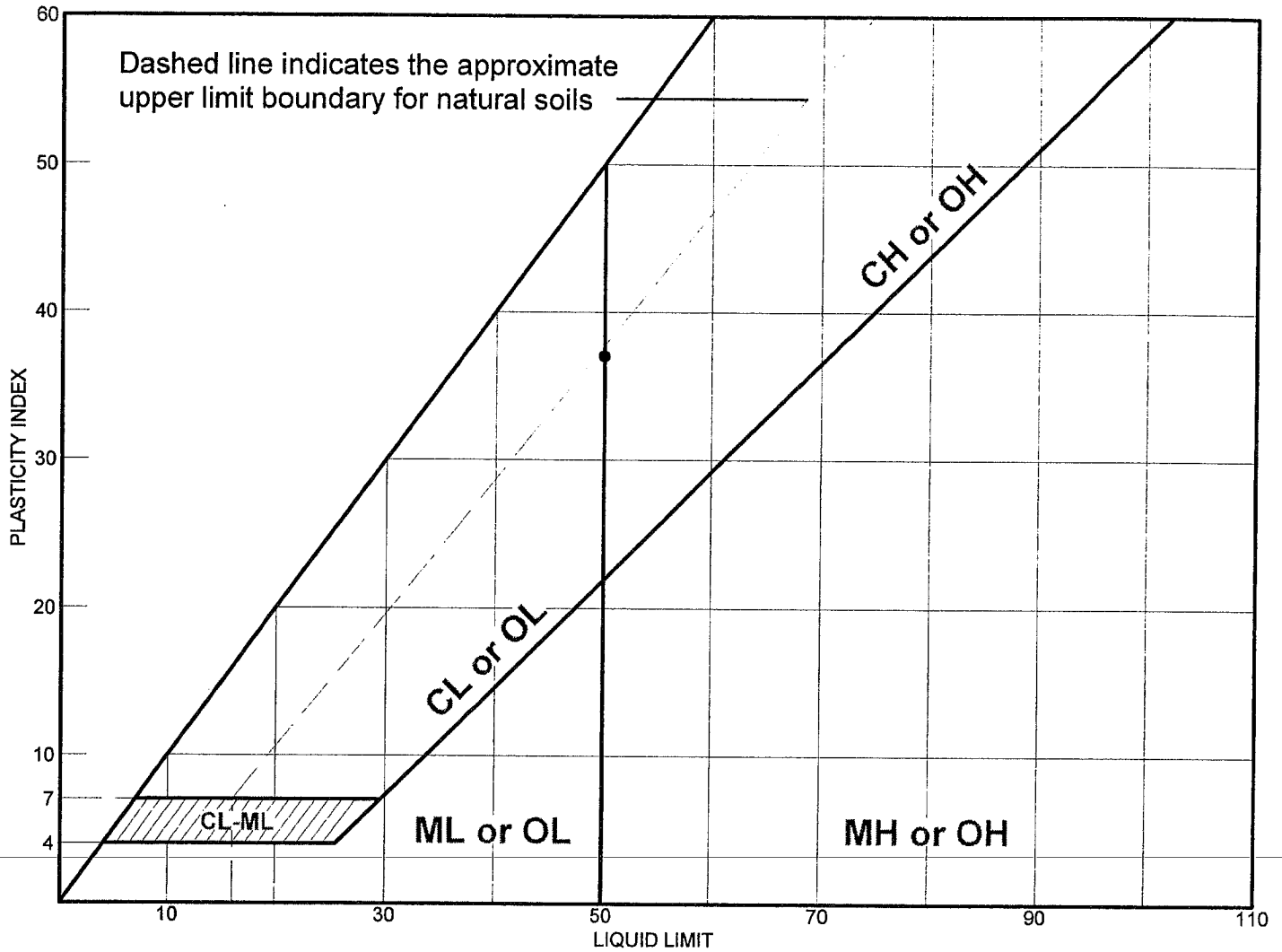

| MATERIAL DESCRIPTION                | LL | PL | PI | %<#40 | %<#200 | USCS |
|-------------------------------------|----|----|----|-------|--------|------|
| • Brown sandy clay (CH) with gravel | 50 | 13 | 37 |       | 57.5   | (CH) |
|                                     |    |    |    |       |        |      |
|                                     |    |    |    |       |        |      |
|                                     |    |    |    |       |        |      |

Project No. 5334.01-N Client:

Project: Falcon Ridge Townhouses

• Source: TB-1

Elev./Depth: 0.0 to 4.0 feet

0.05

Remarks:

•

PEZONELLA ASSOCIATES, INC.

Reno, Nevada

Plate

14

# LIQUID AND PLASTIC LIMITS TEST REPORT

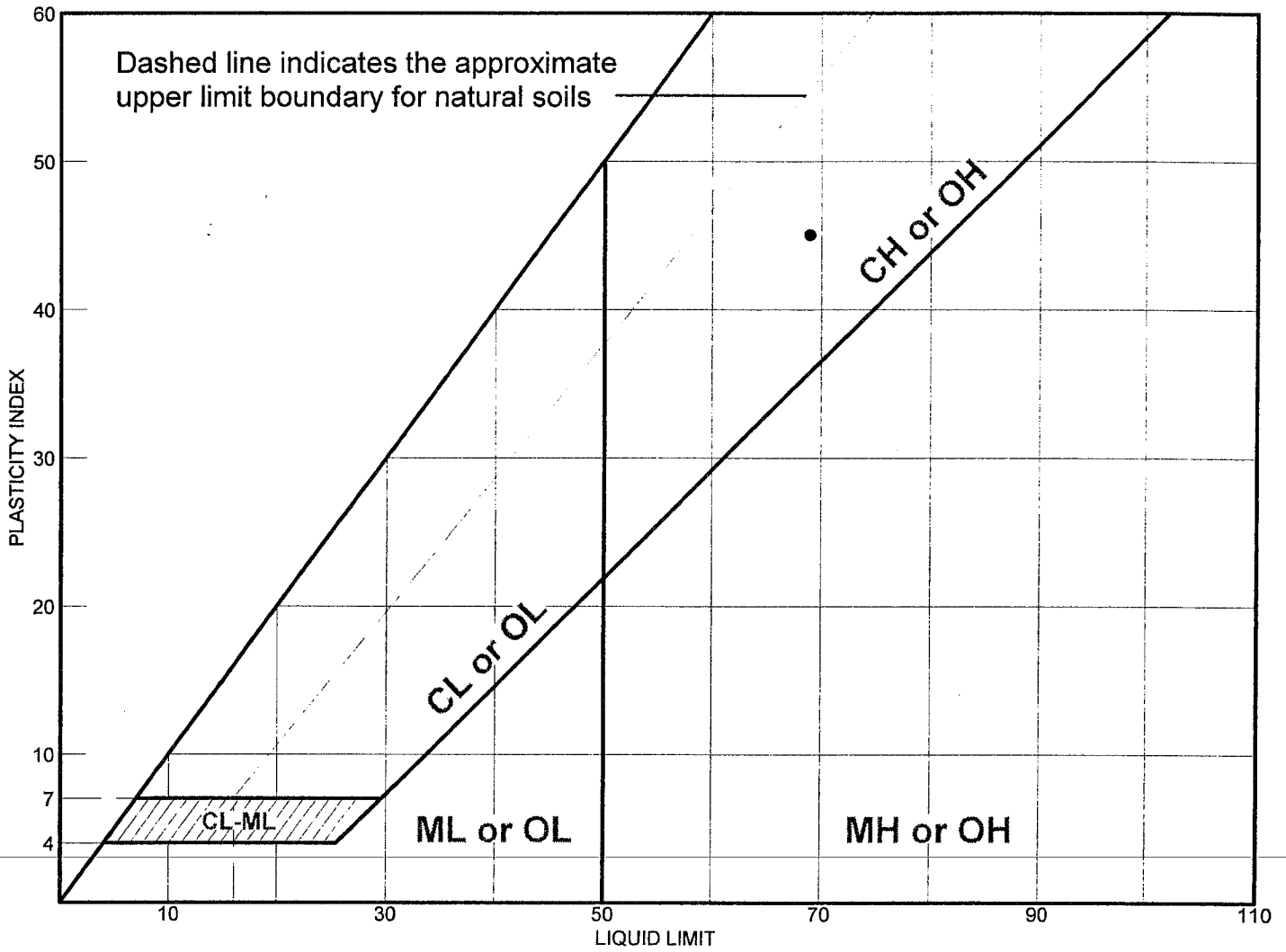

| MATERIAL DESCRIPTION                | LL | PL | PI | %<#40 | %<#200 | USCS |
|-------------------------------------|----|----|----|-------|--------|------|
| ● Brown sandy clay (CH) with gravel | 69 | 24 | 45 |       |        | (CH) |
|                                     |    |    |    |       |        |      |
|                                     |    |    |    |       |        |      |
|                                     |    |    |    |       |        |      |

Project No. 5334.01-N    Client: CDB  
 Project: Falcon Ridge Townhouses  
 ● Source: TB-1    Elev./Depth: 4.0 to 4.5 feet

Remarks:  
 ●

**PEZONELLA ASSOCIATES, INC.**  
 Reno, Nevada

# LIQUID AND PLASTIC LIMITS TEST REPORT

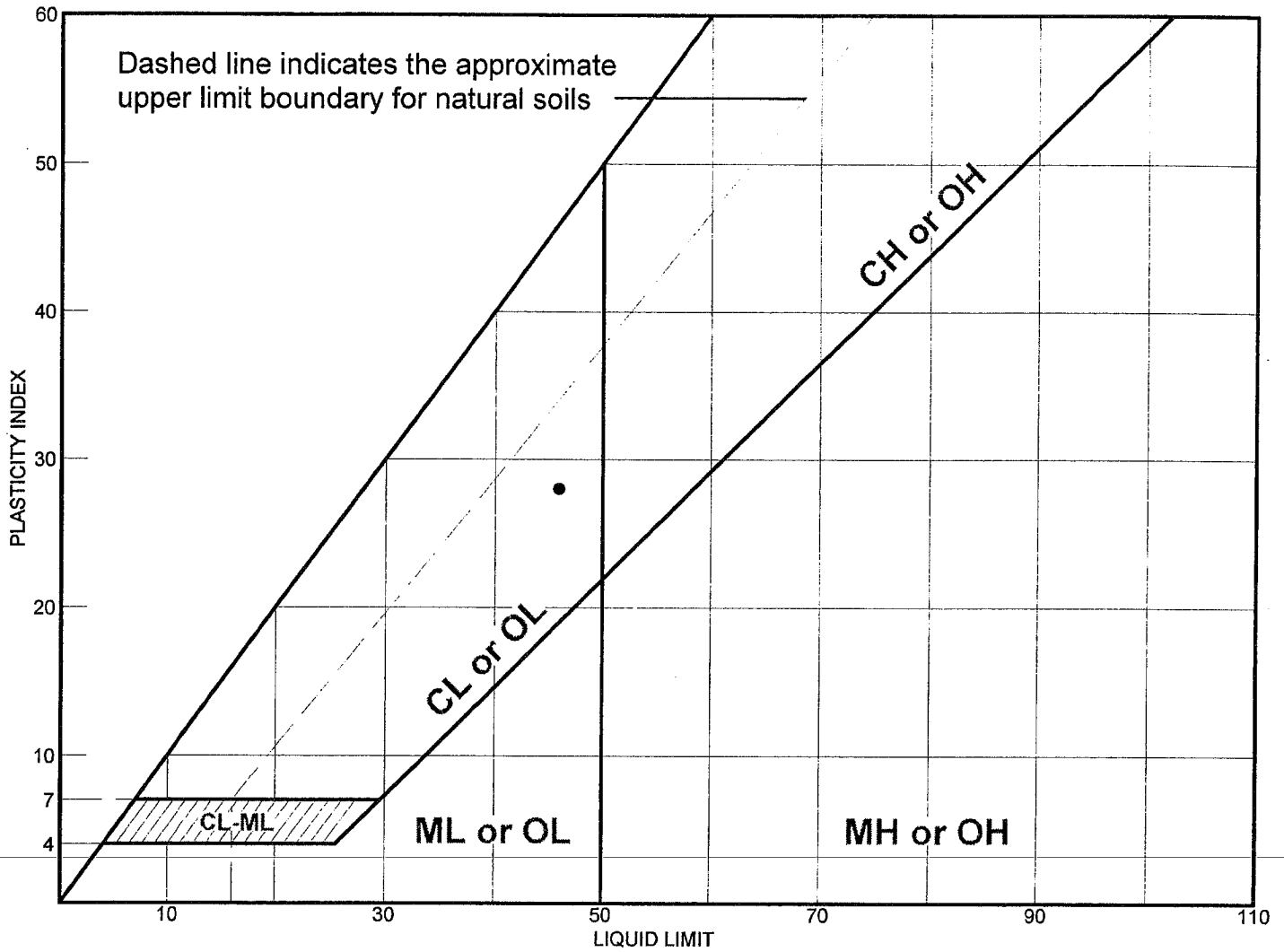

|   | MATERIAL DESCRIPTION               | LL | PL | PI | %<#40 | %<#200 | USCS |
|---|------------------------------------|----|----|----|-------|--------|------|
| ● | Brown clayey sand (SC) with gravel | 46 | 18 | 28 |       | 39.5   | (SC) |
|   |                                    |    |    |    |       |        |      |
|   |                                    |    |    |    |       |        |      |
|   |                                    |    |    |    |       |        |      |

Project No. 5334.01-N    Client: CAB  
 Project: Falcon Ridge Townhouses  
 ● Source: TB-3    Elev./Depth: 4.5 to 5.0 feet

Remarks:  
 ●

**PEZONELLA ASSOCIATES, INC.**  
 Reno, Nevada

SAMPLE LOCATION :           TB-1 @ 0.0 to 4.0 feet          

SOIL TYPE :           BROQN SANDY CLAY (CH) with gravel          

|                      |                                      |
|----------------------|--------------------------------------|
| EXPANSION INDEX:     | <u>          100.3          </u>     |
| POTENTIAL EXPANSION: | <u>          EXPANSIVE          </u> |

When tested in accordance with ASTM D-4829, the classification of potentially expansive soils is based on the IBC Section 1802.3.2 and is summarized in the following table.

| EXPANSION INDEX (EI) | POTENTIAL EXPANSION |
|----------------------|---------------------|
| 0 - 20               | Non-expansive       |
| > 20                 | Expansive           |
|                      |                     |
|                      |                     |
|                      |                     |

**REMARKS :**

Expansion Index was calculated by using  $E_{I_{meas}}$  within 40% & 60% moisture content. This test provides an index to the expansion potential of compacted soil when inundated with distilled water. This test was performed in accordance with ASTM test procedure No. D-4829.

Job No. 5334.01-N

CSB 12-28-05



**PEZONELLA  
ASSOCIATES, INC.**

EXPANSION INDEX  
FALCON RIDGE TOWNHOUSES  
WASHOE COUNTY, NEVADA

Plate No.  
17

# R-VALUE TEST REPORT

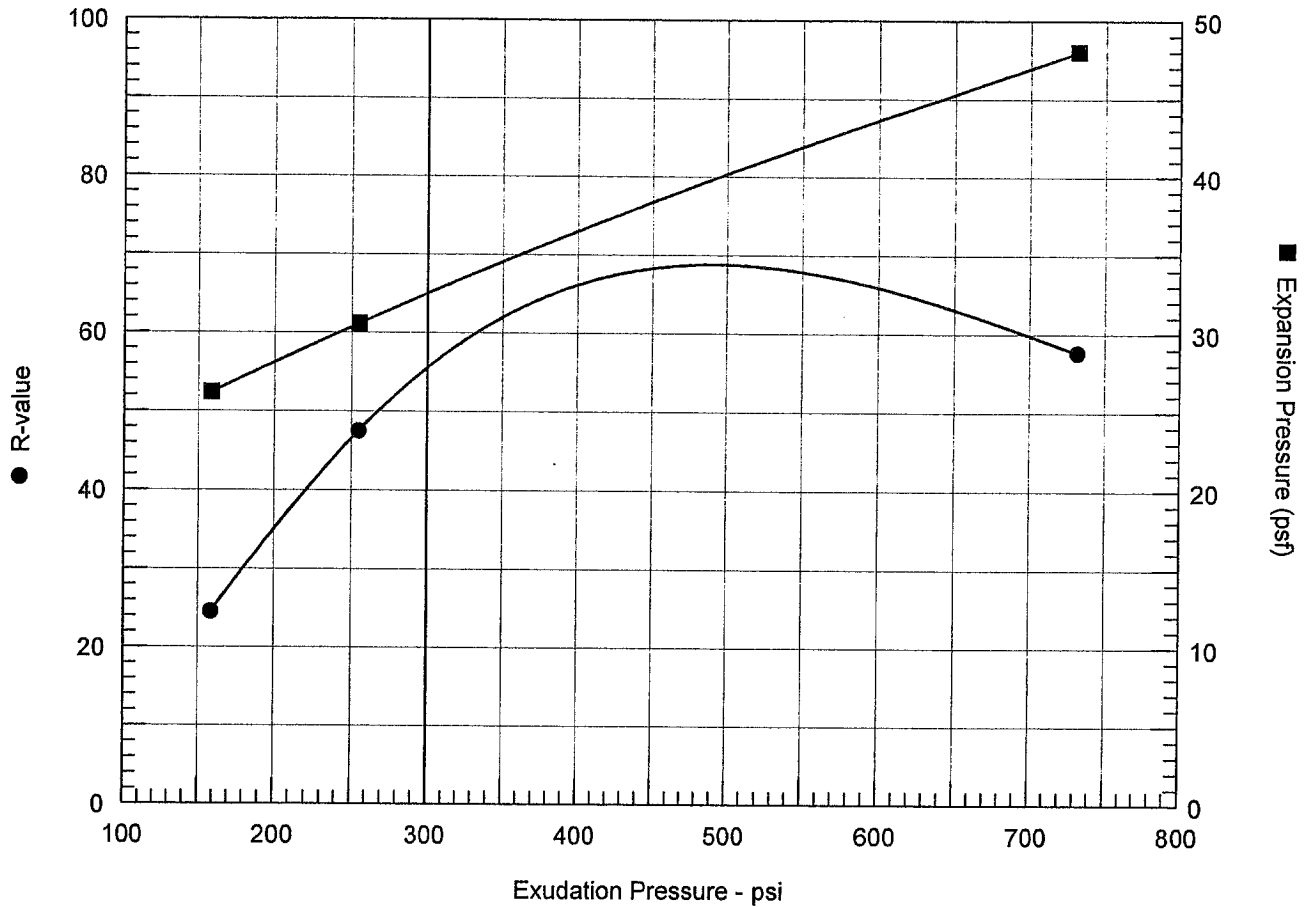

**Resistance R-Value and Expansion Pressure - ASTM D 2844**

| No. | Compact Pressure psi | Density pcf | Moist. % | Expansion Pressure psf | Horizontal Press. psi @ 160 psi | Sample Height in. | Exud. Pressure psi | R Value | R Value Corr. |
|-----|----------------------|-------------|----------|------------------------|---------------------------------|-------------------|--------------------|---------|---------------|
| 1   | 300                  | 125.1       | 12.4     | 26                     | 120                             | 2.70              | 159                | 22      | 25            |
| 2   | 300                  | 119.0       | 10.3     | 48                     | 69                              | 2.68              | 732                | 53      | 58            |
| 3   | 300                  | 131.7       | 11.0     | 31                     | 88                              | 2.70              | 255                | 42      | 47            |

| Test Results  | Material Description  |
|---|---|
| <p>R-value at 300 psi exudation pressure = 56</p> <p>Exp. pressure at 300 psi exudation pressure = 32 psf</p>   | <p>Brown clayey sand (SC) with gravel</p>   |
| <p><b>Project No.:</b> 5334.01-N</p> <p><b>Project:</b> Falcon Ridge Townhouses</p> <p><b>Source of Sample:</b> TB-8                      <b>Depth:</b> 0.0 to 4.0 feet</p> <p><b>Sample Number:</b> 914</p> <p><b>Date:</b> 12/22/2005</p> | <p><b>Tested by:</b></p> <p><b>Checked by:</b><br/>CSB</p> <p><b>Remarks:</b></p> |
| <p>R-VALUE TEST REPORT</p> <p><b>PEZONELLA ASSOCIATES, INC.</b></p>   |   |

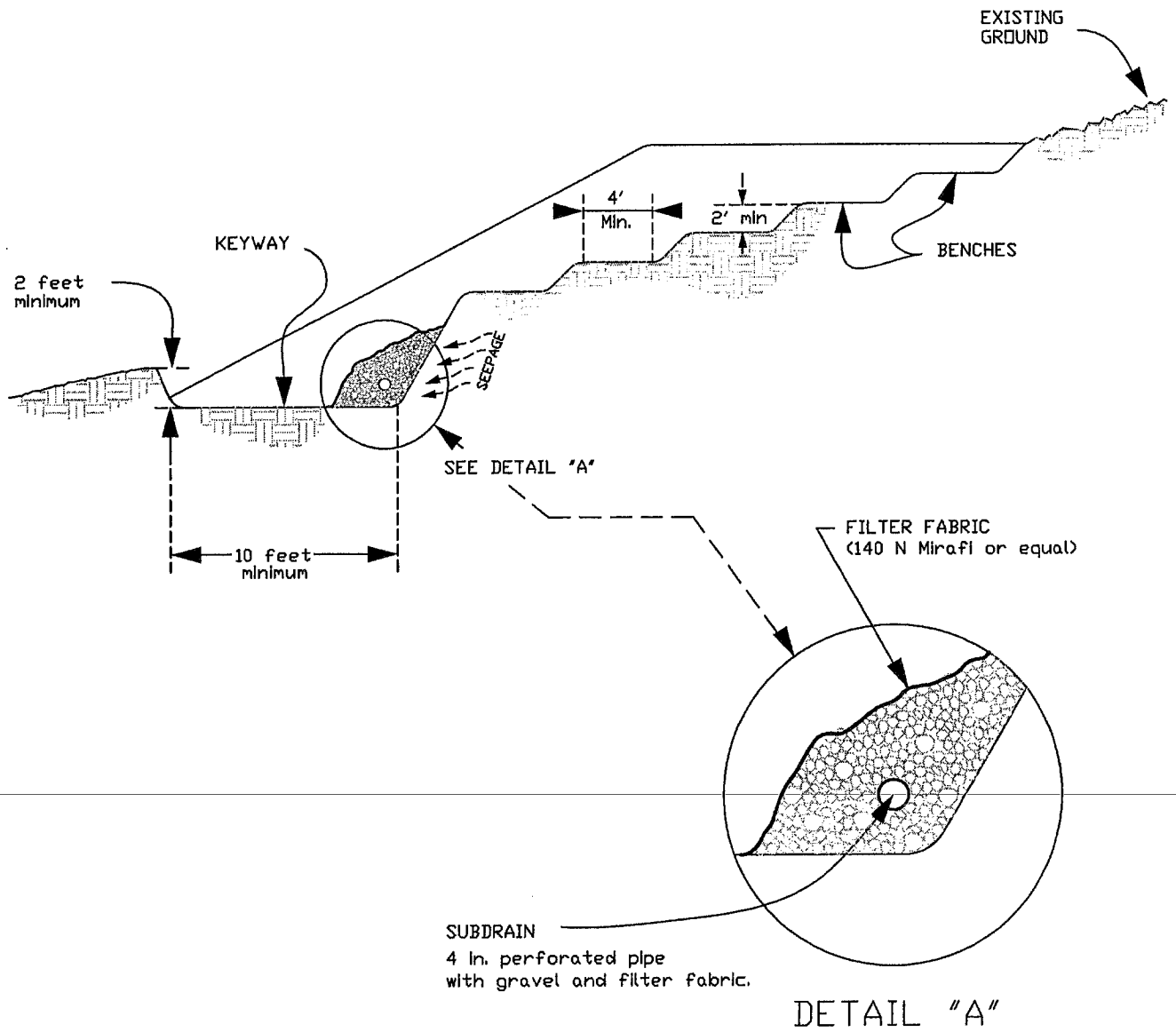

**NOTE:** This detail applies when existing ground slopes are 5:1 and steeper.

Not to Scale

Job No. 5334.01-N

DETAIL FOR FILLING ON SLOPES

CMB /appr./12-28-05

**Pezonella Associates, Inc**  
 Consulting Engineers  
 520 Edison Way Reno, Nevada 89502  
 PHONE (775) 866-6666 FAX (775) 866-8042

FALCON RIDGE TOWNHOUSES  
 WASHOE COUNTY, NEVADA

Plate No.  
**19**



**SPECIFICATIONS FOR  
SITE PREPARATION AND EARTHWORK SPECIFICATION  
PROPOSED  
FALCON RIDGE TOWNHOUSES  
WASHOE COUNTY, NEVADA**

**1.0 GENERAL**

- 1.1 Scope - The work performed under these specifications shall include clearing, stripping, removal of unsuitable materials, preparation of native soils, excavation, placement and compaction of on-site and imported fill material to grades shown on the approved mass grading plan.
- 1.2 Structural Zones - Structural zones are defined as the area 24 inches below and laterally away from exterior flatwork and pavement subgrades. Only approved structural material may be utilized within structural zones.
- 1.3 Mass Zones - Mass zones are defined as all areas outside the structural zones. In general, materials which do not meet the requirements for select or structural fill may be used in mass zones with the prior approval of the Geotechnical Engineer (or his representative in the field) or governing agency.

**2.0 SPECIFICATIONS AND QUALITY ASSURANCE**

- 2.1 Standard Specifications - "Standard Specification(s)" shall mean the Standard Specifications for Public Works Construction, in effect at the time of the final plan approval, as adopted and amended by the governing agency. All work within dedicated areas shall be carried out in conformance with the Standard Specifications unless otherwise specified herein.
- 2.2 ASTM - "ASTM" is the designation for the American Society for Testing and Materials.
- 2.3 Percent Relative Compaction - Percent relative compaction is defined as the required in-place unit weight of material, expressed as a percentage of the maximum dry unit weight of the same material, determined by the laboratory procedure outlined in ASTM Test Designation: D 1557.
- 2.4 Optimum Moisture Content - Optimum moisture content is defined as the percent of moisture (by dry weight) corresponding to the maximum dry density of the same material as determined by the laboratory procedure outlined in ASTM Test Designation: D 1557.
- 2.5 Geotechnical Engineer - A Geotechnical Engineer (or his representative in the field), retained by the Owner or Developer, shall provide continuous observations and testing services during site grading operations and periodic inspection during all other construction to enable him to document that all areas (except horizontal and vertical grade control) were constructed in accordance with the accepted project plans, these specifications and the Standard Specifications.

2.6 Soil Density and Quality Tests - Sufficient soil density and quality tests shall be performed and submitted to the Owner or Developer to support the Geotechnical Engineer's documentation of compliance. The cost of re-inspection and re-testing, as a result of unsatisfactory work, shall be deducted from the Contractor's contract price.

**3.0 MATERIALS**

3.1 General - All fill material shall be free of organic matter or debris and shall be approved by the Geotechnical Engineer prior to its use. All fill material shall be submitted to the Geotechnical Engineer (or his representative in the field) for testing and approval at least 10 working days in advance of hauling or placement. For consideration within the text of these specifications, soils generated by grading will be classified as on-site and native soils.

3.2 Structural Fill Material - Structural fill material shall be used in structural zones and shall be approved by the Geotechnical Engineer (or his representative in the field) and be free of organic matter or debris and conform with requirements included in the latest edition of *Standard Specifications for Public Works Construction*:

| <u>Sieve Size</u> | <u>Percent Passing<br/>(by dry weight)</u> |
|-------------------|--|
| 4 Inch            | 100  |
| 3/4 Inch          | 70 - 100                                   |
| No. 40            | 15 - 70                                    |
| No. 200           | 5 - 25                                     |

---

Liquid Limit = 40 Maximum  
Plasticity Index = 12 Maximum  
Resistance Value = 30 Minimum

- 3.3 Rock Fill - Rock fill is defined as any material with more than 30 percent retained on the 3/4-inch sieve size. Rock fill is suitable for use in structural zones provided the maximum rock size is less than 6 inches, and with approval by the Geotechnical Engineer (or his representative in the field) or governing agency.
- 3.4 Imported Materials - Imported material shall be approved by the Geotechnical Engineer prior to use. The Contractor shall give at least 10 days notice prior to using the imported material to enable the Geotechnical Engineer (or his representative in the field) to sample and test the material.
- 3.5 Expansive Materials - Where referred to within the text of this report, materials with a potential for expansion are defined as having a Liquid Limit greater than 40, a Plasticity Index greater than 15, an Expansion Index greater than 20 and in excess of 12 percent passing the No. 200 sieve. Materials with Liquid Limits of 40 or less, Plasticity Index of 15 or less, and an Expansion Index less than 20 exhibit very low to negligible potential for expansion.

**4.0 SITE PREPARATION**

4.1 Clearing and Stripping - Areas to be graded shall be cleared of all debris and mowed of vegetation. Debris shall be removed from the site; however, mowed vegetation may be stockpiled for reuse in landscape areas. Subsequently, as directed by the Geotechnical Engineer (or his representative in the field) any organic laden soils should be stripped and removed from the site or evenly blended with soil and reused in landscape areas. Particular attention should be given to the complete removal of roots associated with trees and shrubs and within drainages. Generally, minor root systems remaining after clearing and stripping may be tilled in-place through the use of a disk harrow or equivalent equipment.

4.2 Wasting of Vegetation and Organics - Mowed vegetation and stripped soils containing roots or organic material may be stockpiled for use in landscape or wasted in designated "non-structural" areas. These materials should be evenly blended with soil, moisture conditioned, placed in 8-inch loose lifts and compacted to provide a surface which is firm. Delineation of any designated "non-structural" areas where vegetation or organics are wasted should be illustrated on the approved plans in order to facilitate future development if proposed.

4.3 Surface Preparation - The surfaces exposed by clearing, stripping or overexcavation should be observed by the Geotechnical Engineer (or his representative in the field) to document that the conditions are as anticipated. Generally, materials remaining after clearing and stripping should be scarified to a depth of 6 inches, moisture conditioned to near optimum (plus 2 to 4 percent over optimum if clayey) and compacted to at least 90 percent relative compaction. If the exposed soils contain abundant oversize material (gravel or cobbles) or are at a suitable and uniform moisture content, the scarifying requirements may be waived by the Geotechnical Engineer (or his representative in the field). Additionally, if the exposed surface contains abundant fine grain particles which can impede attaining the specified compaction, the surface shall be moisture conditioned to near optimum and compacted to provide a surface which is smooth and non-yielding.

4.4 Approval - Before placing any new fill, the Contractor shall obtain the Geotechnical Engineer's (or his representative in the field) approval of the site preparation in each area.

## **5.0 FILL PLACEMENT AND COMPACTION**

5.1 Erosion Control - The Contractor shall take all precautions needed to prevent erosion and conduct earthmoving operations using applicable practices outlined in the most recent edition of the *Handbook of Best Management Practices*.

- 5.2 Structural Fill - All structural fill material shall be moisture conditioned to near optimum and compacted with approved equipment to achieve at least 95 percent relative compaction. Lift thickness will be restricted to a maximum of 8 inches (loose) unless the Contractor can demonstrate his ability to uniformly achieve the required compaction for the entire layer of fill placed. Field density tests shall be performed by the Geotechnical Engineer to determine relative compaction of each lift of fill. These tests shall be performed in the compacted material below the disturbed surface.
- 5.3 Mass Fill - All mass fill material shall be moisture conditioned to near optimum (2 to 4 percent over optimum if clayey) and compacted with approved equipment to achieve at least 90 percent relative compaction. Lift thickness will be restricted to a maximum of 8 inches (loose) unless the Contractor can demonstrate his ability to uniformly achieve the required compaction for the entire layer of fill placed. Field density tests shall be performed by the Geotechnical Engineer to determine relative compaction of each lift of fill. These tests shall be performed in the compacted material below the disturbed surface.

- 5.4 Rock Fill - Rock fill shall be spread in lifts not exceeding 12 inches in uncompacted thickness and placed in such a manner that no voids are present after compacting the layer. Unless otherwise directed by the Geotechnical Engineer, the Grading Contractor shall make at least 4 passes (performance specification) with compactor equipment approved by the Geotechnical Engineer (or his representative in the field) for each lift of rock fill. The final lift thickness and number of compaction passes shall be determined by the Geotechnical Engineer (or his representative in the field) during grading when compaction characteristics of the on-site material is known. Prior to compacting, the lift surface shall be smoothed evenly with bladed equipment. Oversized rock (exceeding 6 inches in diameter) shall be removed from the lift surface.
- 5.5 Recompaction - Where the field moisture and density tests indicate that the required moisture content and/or compaction of any layer of fill or portion thereof has not been attained, the particular layer or portion shall be reconditioned to a suitable moisture content and recompacted to the required density prior to placing additional fill material. The Contractor shall be responsible for placing and compacting approved fill material in accordance with these specifications. Should the Contractor fail to meet the compaction requirement, he shall reduce the rate of haul, furnish additional spreading, watering, mixing, and/or compaction equipment, and make other adjustments necessary to produce a satisfactorily compacted fill.



- 5.6 Seasonal Limits - No fill material shall be placed, spread or rolled while it is frozen or thawing or during unfavorable weather conditions. When the work is interrupted by seasonal runoff, heavy rain or snow, fill operations shall not be resumed until the Geotechnical Engineer (or his representative in the field) indicates that the moisture content and density of the previously placed fill are as specified. If any surface or layer becomes frozen, earthwork construction cannot proceed until it is allowed to thaw. The Earthwork Contractor shall obtain approval from the Geotechnical Engineer (or his representative in the field) of each lift prior to placement of subsequent fill.
- 5.7 Slopes - All permanent cut and fill slopes shall be constructed with a maximum inclination of two horizontal to one vertical (2:1). Where fill is to be placed on natural slopes of 5:1 or steeper, keying and benching shall be provided along the fill/native soil interface. A keyway, located at the base of the slope, shall be at least 2 feet in depth (or into competent material) and 10 feet in width. The face of the slope should be planted with dense-rooted, rapid growing vegetation. A perforated pipe should be installed within the keyway area to allow for drainage of any migrating (seepage) water. The pipe should extend the length of the keyway and daylight at a suitable low point to allow for disposal. The pipe should be completely encapsulated with crushed, 3/4-inch gravel and a filter fabric (i.e. Mirafi 140 N or equal) material should be placed above the gravel layer prior to placing fill material (see attached Plate 19).

- 5.8 Slope Height and Bench Width - In general, individual slopes shall not be taller than 15 feet in height, and all benches shall be at least 5 feet in width. A 3-foot-wide rock lined drainage swale with positive drainage, sufficient to divert runoff and suspended material down and away from the slope should be installed at the top of all slopes and on individual benches. Protective fencing should be considered at the very top of all to contain any oversize aggregate which may become dislodged and/or to discourage activity along the slopes.
- 5.9 Finish -The Contractor shall overfill and trim the face of all fill slopes or compact them to provide a firm surface, free of loose soil that would be subject to erosion and sloughing. To further minimize erosion potential and future maintenance, upon completion of grading, all two to one (2:1) should be protected, in general, with an 8- to 18-inch layer of rip rap stabilization. Where two to one (2:1) slopes less than 15 feet in height and all three to one (3:1) or flatter slopes are proposed, the face of the slope should be planted (via hydroseed or hydromulch) with dense-rooted, rapid growing vegetation. All slopes should be evaluated by the Geotechnical Engineer to document that the conditions are as anticipated and that slope height and bench widths are appropriate.
- 5.10 Slope Rip Rap - Rip rap material should consist of well graded 6- to 12-inch angular rock fragments from a competent (sound) source, exhibit a minimum specific gravity of at least 2.2 and an absorption of less than 4 percent.