



Board of Adjustment Staff Report

Meeting Date: May 4, 2023

Agenda Item: 8D

SPECIAL USE PERMIT CASE NUMBER: WSUP23-0009 (449 Lakeshore Blvd)

BRIEF SUMMARY OF REQUEST: To allow for a driveway traversing 30% or greater slopes, and to vary grading standards.

STAFF PLANNER: Chris Bronczyk, Senior Planner
Phone Number: 775.328.3612
E-mail: cbronczyk@washoecounty.gov

CASE DESCRIPTION

For hearing, discussion, and possible action to approve a special use permit to allow for a driveway to traverse a slope of thirty (30) percent or greater; to construct a permanent earthen structure greater than 4.5 feet in height within the required front yard setback; excavation of 1,000 cubic yards on slopes greater than 15%; and grading of one-half (0.5) acre (21,780 sf) or more on parcels less than six acres in size. The proposal is also requesting to vary standards found in Washoe County Code (WCC) Section 110.438.45(a) to allow slopes in excess of, or steeper than, three horizontal to one vertical (3:1); WCC Section 110.438.45(d) to allow retaining walls taller than four and one-half (4.5) feet within the front yard setback; and WCC Section 110.438.45(c) to allow finished grading to vary from the natural slope by more than ten (10) feet in elevation.

Applicant/Owner: Myers Family Trust
Location: 449 Lakeshore Blvd
APN: 123-250-08
Parcel Size: 1.32 acres
Master Plan: Crystal Bay (CB)
Regulatory Zone: Tahoe_Crystal Bay (TA_CB)
Area Plan: Tahoe
Development Code: Authorized in Article 810, Special Use Permits
Commission District: 1 – Commissioner Hill

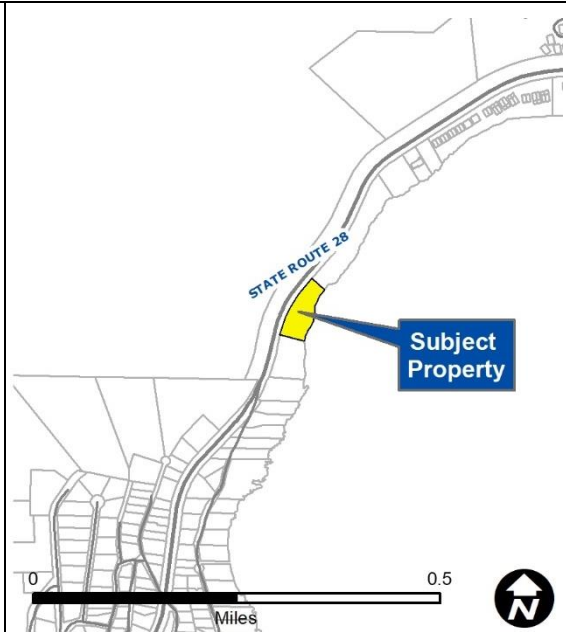

Vicinity Map

STAFF RECOMMENDATION

APPROVE

APPROVE WITH CONDITIONS

DENY

POSSIBLE MOTION

I move that, after giving reasoned consideration to the information contained in the staff report and information received during the public hearing, the Washoe County Board of Adjustment approve with conditions Special Use Permit Case Number WSUP23-0009 for Myers Family Trust, with the conditions included as Exhibit A to this matter, having made all five findings in accordance with Washoe County Code Section 110.810.30 and approve the request to vary the development code standards set forth in WCC 110.438.45(a), WCC 110.438.45(d) and WCC 110.438.45(c) as set forth in the staff report:

(Motion with Findings on Page 9)

Staff Report Contents

Special Use Permit 3

Site Plan..... 4

Project Evaluation 5

Standards Proposed to be Modified..... 7

Reviewing Agencies..... 8

Recommendation 9

Motion 9

Appeal Process..... 10

Exhibits Contents

Conditions of Approval..... Exhibit A

Agency Comments..... Exhibit B

Public Notice Exhibit C

Project Application Exhibit D

Special Use Permit

The purpose of a special use permit is to allow a method of review to identify any potential harmful impacts on adjacent properties or surrounding areas for uses that may be appropriate within a regulatory zone; and to provide for a procedure whereby such uses might be permitted by further restricting or conditioning them so as to mitigate or eliminate possible adverse impacts. If the Board of Adjustment grants an approval of the special use permit, that approval is subject to conditions of approval. Conditions of approval are requirements that need to be completed during different stages of the proposed project. Those stages are typically:

- Prior to permit issuance (i.e. a grading permit, a building permit, etc.)
- Prior to obtaining a final inspection and/or a certificate of occupancy on a structure
- Prior to the issuance of a business license or other permits/licenses
- Some conditions of approval are referred to as “operational conditions.” These conditions must be continually complied with for the life of the business or project.

The conditions of approval for Special Use Permit Case Number WSUP23-0009 are attached to this staff report and will be included with the action order.

Additionally, Article 810, Special Use Permits, allows the Board of Adjustment to vary development code standards in conjunction with the approval process per WCC 110.810.20(e) The Board of Adjustment will be ruling on the request(s) to vary standards below:

Relevant Code	Relevant Code Variance(s) Requested
110.438.45 (d)	Within the front yard setback area of any parcel with a residential use or zoned for residential use, retaining walls are limited to a maximum height of four and one-half (4.5) feet
110.438.45(c)	Finish grading shall not vary from the natural slope by more than ten (10) feet in elevation.
110.438.45(a)	Grading shall not result in slopes in excess of, or steeper than, three horizontal to one vertical (3:1).

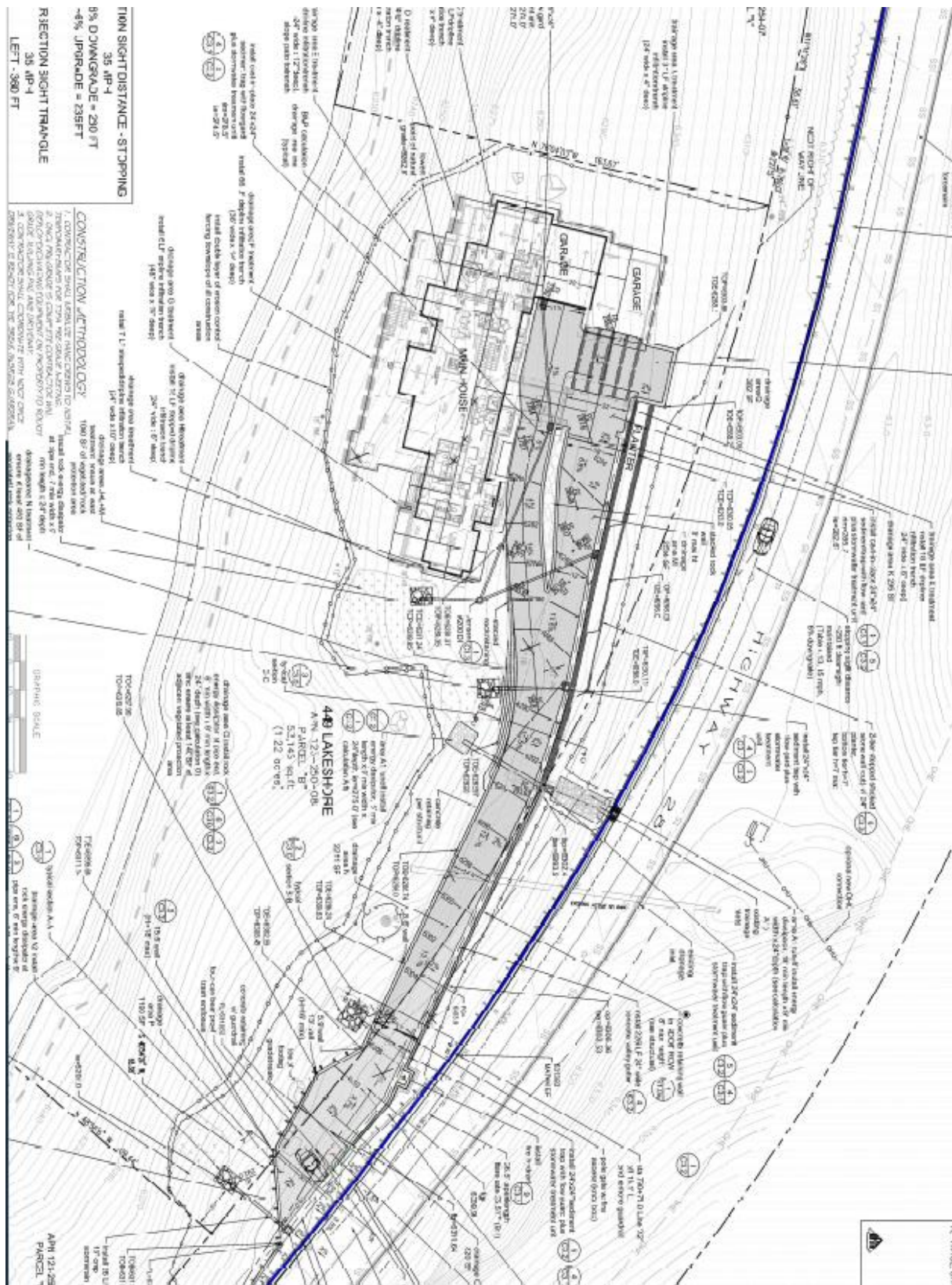

Site Plan

Project Evaluation

The proposed special use permit (SUP) was heard and approved by the Washoe County Board of Adjustment in February of 2021. However, construction was delayed and the SUP has since expired. The current proposal is identical to the February 2021 proposal. The applicant notes that all permits and approvals, such as those from TRPA and NDOT, referenced in the resubmittal remain valid.

The applicant is proposing to construct a driveway traversing 30% or greater slopes, which triggers a major grading threshold, and thus requires approval of a special use permit by the Board of Adjustment (BOA). In addition to the driveway, there are a number of other major grading thresholds that have been triggered as part of this application.

Code	Major Grading that requires an SUP
110.438.35(a)(2)(i)(A)	Grading of one-half (0.5) acre (21,780 sf) or more on parcels less than 6 acres in size.
110.438.35(a)(2)(ii)(A)	Excavation of one thousand (1,000) cubic yards or more whether the material is intended to be permanently located on the project site or temporarily stored on a site for relocation to another, final site.
110.438.35(a)(3)	Any driveway or road that traverses any slope of thirty (30) percent or greater (steeper)
110.438.35(a)(4)	Grading to construct a permanent earthen structure greater than four and one-half (4.5) feet in height within the required front yard setback, or greater than six (6) feet in height on the remainder of the property. The height of an earthen structure is measured from existing grade at the time of permit issuance

The subject parcel has a regulatory zone of Tahoe_Crystal Bay (TA_CB) and is currently vacant. The proposed grading will occur on an area of approximately 28,380 square feet, with 1,398 cubic yards of cuts and 766 cubic yards of fill to facilitate the construction of a driveway for a new custom single-family residence which will be constructed on the south side of the parcel. Excess fill will be exported.

The driveway will connect to Lakeshore Blvd. (State Route 28) at the northern edge of the site. The driveway is proposed to be paved and 14 feet wide. The gate will be a fire department accessible gate. The proposed private driveway widens at the northern end to allow for vehicle turning movements, the intent is to accommodate a right-turn-in for cars entering the site from State Route 28. The widening also allows for the location of a bear proof trash enclosure required by TRPA. The gate is located in such a way to allow for stacking of up to 4 vehicles to ensure that back-ups do not occur along Lakeshore Blvd. The site contains numerous large shrubs, trees, and native vegetation.

The application is also asking to vary several standards of Article 438 as described in detail further in this staff report. Most of the graded area will be covered by impervious surfaces such as the paved driveway or the footprint of the proposed residence; however, grading will result in fill material resulting in the creation of a permanent earthen structure greater than 4.5 feet in height within the front yard setback.

The parcel is a lakefront property, situated on steep slopes in Crystal Bay. Due to the parcel and proposed location of the residence being below the roadway, and the proposed driveway having to traverse the fill slopes associated with the roadway, the driveway is required to traverse slopes of greater than 30% natural grade. It is staff's opinion that due to the constraints on this property, this special use permit is necessary to develop a residence on this property.

The grading will occur primarily for the construction of the driveway building pad and retaining walls. All development must adhere to TRPA land capability designations or Individual Parcel Evaluation System (IPES). The grading that takes place within the right-of-way, is regulated by

Nevada Department of Transportation (NDOT); Washoe County does not have regulatory jurisdiction over these areas.

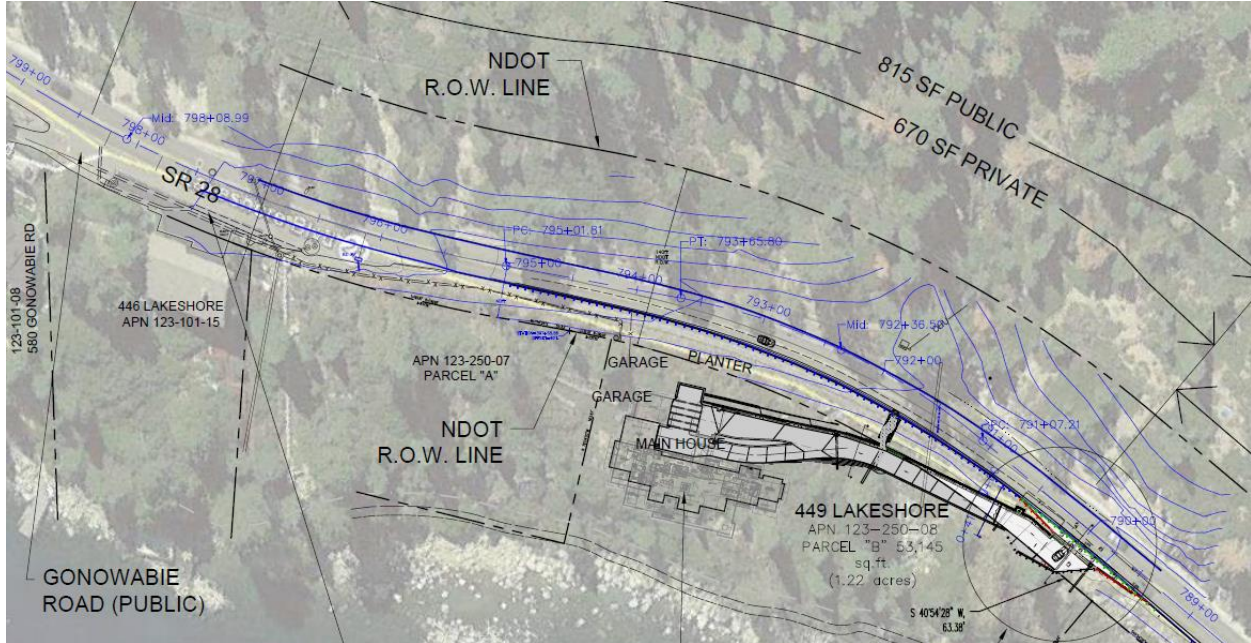

Site Plan with NDOT Right of Way

The application states that a combination of walls and revegetation will be used to stabilize slopes disturbed from the driveway grading. This includes the use of rock walls, poured-in-place concrete walls, native vegetation, erosion mats, and formal landscaping. The application notes that the rocky walls will not exceed 6 feet in height. Walls taller than 6 feet will utilize poured-in-place concrete walls.

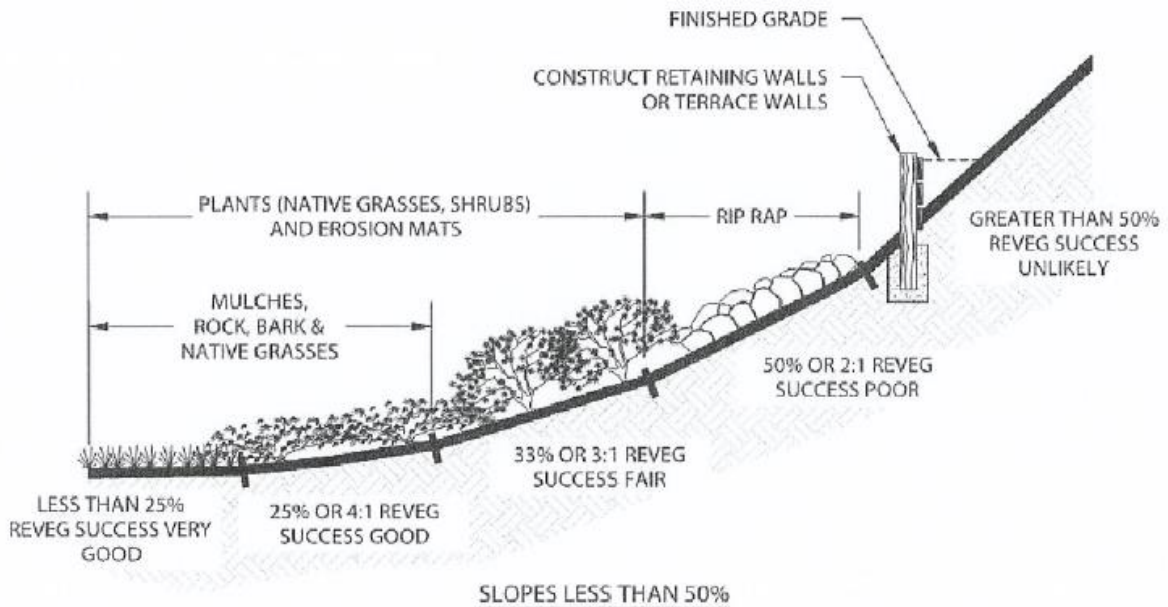

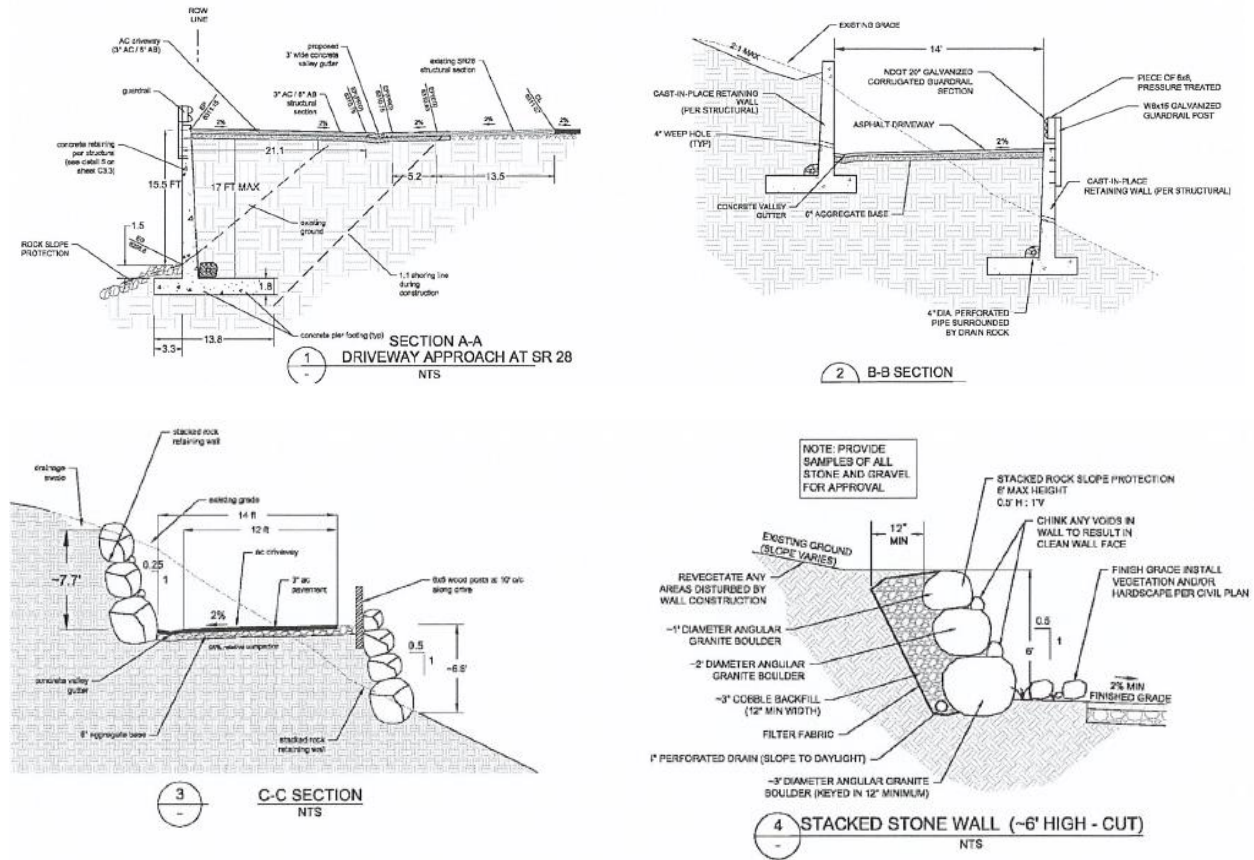

Standards Proposed to be Modified

The applicant is requesting to modify multiple standards within Washoe County Code Article 438, Major Grading.

- 110.438.45 (d): Within the front yard setback area of a parcel with a residential use or zoned for residential use, retaining walls are limited to a maximum of four and one-half (4.5) feet.
- 110.438.45(c): Finish grading shall not vary from the natural slope by more than ten (10) feet in elevation.

The applicant states, in order to successfully achieve access to the proposed residence while maintaining the maximum driveway slope permitted over the steep topography, it requires a retaining wall to be greater than 4.5 feet in height within the front yard setback. The maximum height of the concrete walls in the front yard setback are proposed to be approximately 15.5 feet. The use of the walls will reduce the required grading and scarring of the proposed site.

The applicant is also requesting to modify:

- 110.438.45(a): Grading shall not result in slopes in excess of, or steeper than, three horizontal to one vertical (3:1):

The applicant states that the steep terrain between Lakeshore Boulevard and the proposed homesite includes natural 1:1 slopes in some locations, and due to the steepness of the slopes in this area the Washoe County Development Code requirement of 3:1 slopes would ultimately result in significant scarring of the property. The applicant is requesting slopes up to 1:1 be permitted in order to match the natural topography of the site. The applicant states that the slopes will be stabilized through the use of walls, erosion mats, revegetation, and landscaping. The applicant also states that the grading and stabilization methods will comply with TRPA's

standards.

Due to the topography of the site, staff is in support of the three requested modifications. Additionally, without these modifications the site would be undevelopable.

Reviewing Agencies

The following agencies/individuals received a copy of the project application for review and evaluation.

Agencies	Sent to Review	Responded	Provided Conditions	Contact
NDOT (Transportation)	X			
Washoe County Building & Safety	X			
Washoe County Engineering & Capital Projects	X			
Washoe County Land Development (All Apps)	X	X	X	Rob Wimer, rwimer@washoecounty.gov
Washoe County Parks & Open Space	X	X		
Washoe County Sewer	X	X		
Washoe County Traffic	X	X	X	Mitch Fink, MFink@washoecounty.gov
Washoe County Water Rights Manager (All Apps)	X	X		
WCHD Air Quality	X			
WCHD EMS	X	X		
WCHD Environmental Health	X	X		
Washoe-Storey Conservation District	X	X	X	Jim Shaffer, shafferjam51@gmail.com
Incline Village Roads	X			
IVGID	X	X	X	Tim Buxton, tim_buxton@ivgid.org
IVGID - Parks	X			
Nevada Tahoe Conservation District	X			
North Lake Tahoe FPD	X	X	X	John James, jjames@nltpd.net
Tahoe Regional Planning Agency	X			
Tahoe Transportation District	X			

All conditions required by the contacted agencies can be found in Exhibit A, Conditions of Approval.

Staff Comment on Required Findings

WCC Section 110.810.30, Article 810, *Special Use Permits*, requires that all of the following findings be made to the satisfaction of the Washoe County Board of Adjustment before granting approval of the request. Staff has completed an analysis of the special use permit application and has determined that the proposal is in compliance with the required findings as follows.

- (a) Consistency. That the proposed use is consistent with the action programs, policies, standards and maps of the Master Plan and the Tahoe Area Plan.

Staff Comment: There are no specific policies or action programs included in the Master Plan or Tahoe Area Plan that are applicable to the proposed grading for a driveway, therefore the proposed grading is found to be consistent.

- (b) Improvements. That adequate utilities, roadway improvements, sanitation, water supply, drainage, and other necessary facilities have been provided, the proposed improvements are properly related to existing and proposed roadways, and an adequate public facilities determination has been made in accordance with Division Seven.

Staff Comment: Adequate roadways, sanitation, water supply, drainage, and other necessary facilities and utilities will be provided to the site, as the grading is intended to create appropriate access and facilitate construction of a single-family residence.

- (c) Site Suitability. That the site is physically suitable for major grading, and for the intensity of such a development.

Staff Comment: The site is physically consistent with the Crystal Bay area of the Tahoe Basin. Slopes are steep, but if the requests are approved, the site would be suitable for grading and a single-family residence.

- (d) Issuance Not Detrimental. That issuance of the permit will not be significantly detrimental to the public health, safety or welfare; injurious to the property or improvements of adjacent properties; or detrimental to the character of the surrounding area.

Staff Comment: The issuance of the permit will not be significantly detrimental to the public health, safety or welfare; injurious to the property or improvements of adjacent properties; or detrimental to the character of the surrounding area. Approval of the request would provide adequate access to a single-family home on a particularly constrained site.

- (e) Effect on a Military Installation. Issuance of the permit will not have a detrimental effect on the location, purpose or mission of the military installation.

Staff Comment: Issuance of this permit will not have a detrimental effect on the location, purpose, or mission of a military installation.

Recommendation

After a thorough analysis and review, Special Use Permit Case Number WSUP23-0009 is being recommended for approval with conditions. Staff offers the following motion for the Board’s consideration.

Motion

I move that, after giving reasoned consideration to the information contained in the staff report and information received during the public hearing, the Washoe County Board of Adjustment approve with conditions Special Use Permit Case Number WSUP23-0009 for Myers Family Trust, with the conditions included as Exhibit A to this matter, having made all five findings in accordance with Washoe County Code Section 110.810.30 as listed below, and approve the applicant’s request to vary the development code standards set forth in WCC 110.438.45(a), WCC 110.438.45(d) and WCC 110.438.45(c) as set forth in the staff report.

- (a) Consistency. That the proposed use is consistent with the action programs, policies, standards and maps of the Master Plan and the Tahoe Area Plan;

- (b) Improvements. That adequate utilities, roadway improvements, sanitation, water supply, drainage, and other necessary facilities have been provided, the proposed improvements are properly related to existing and proposed roadways, and an adequate public facilities determination has been made in accordance with Division Seven;
- (c) Site Suitability. That the site is physically suitable for major grading, and for the intensity of such a development;
- (d) Issuance Not Detrimental. That issuance of the permit will not be significantly detrimental to the public health, safety or welfare; injurious to the property or improvements of adjacent properties; or detrimental to the character of the surrounding area;
- (e) Effect on a Military Installation. Issuance of the permit will not have a detrimental effect on the location, purpose or mission of the military installation.

Appeal Process

Board of Adjustment action will be effective 10 calendar days after the written decision is filed with the Secretary to the Board of Adjustment and mailed to the applicant, unless the action is appealed to the Washoe County Board of County Commissioners, in which case the outcome of the appeal shall be determined by the Washoe County Board of County Commissioners. Any appeal must be filed in writing with the Planning and Building Division within 10 calendar days from the date the written decision is filed with the Secretary to the Board of Adjustment Commission and mailed to the applicant.

Applicant / Owner: Myers Family Trust.,
Attn: Josh Myers
Jgm@blackstonedevelopmentgroup.com

Representatives: Christy Corporation, Ltd.,
Attn: Mike Railey
Mike@christynv.com

Tahoe Agencies: North Lake Tahoe Fire Protection District.,
Attn: Jennifer Donohue, Ryan Sommers, John James
idonohue@nltpfd.net; rsommers@nltpfd.net; jjames@nltpfd.net

Incline Village General Improvement District.,
Attn: Tim Buxton
tim_buxton@ivgid.org



Conditions of Approval

Special Use Permit Case Number WSUP23-0009

The project approved under Special Use Permit Case Number WSUP23-0009 shall be carried out in accordance with the conditions of approval granted by the Board of Adjustment on May 4, 2023. Conditions of approval are requirements placed on a permit or development by each reviewing agency. These conditions of approval may require submittal of documents, applications, fees, inspections, amendments to plans, and more. These conditions do not relieve the applicant of the obligation to obtain any other approvals and licenses from relevant authorities required under any other act.

Unless otherwise specified, all conditions related to the approval of this special use permit shall be met or financial assurance must be provided to satisfy the conditions of approval prior to issuance of a grading or building permit. The agency responsible for determining compliance with a specific condition shall determine whether the condition must be fully completed or whether the applicant shall be offered the option of providing financial assurance. All agreements, easements, or other documentation required by these conditions shall have a copy filed with the County Engineer and the Planning and Building Division.

Compliance with the conditions of approval related to this special use permit is the responsibility of the applicant, his/her successor in interest, and all owners, assignees, and occupants of the property and their successors in interest. Failure to comply with any of the conditions imposed in the approval of the special use permit may result in the institution of revocation procedures.

Washoe County reserves the right to review and revise the conditions of approval related to this Special Use Permit should it be determined that a subsequent license or permit issued by Washoe County violates the intent of this approval.

For the purpose of conditions imposed by Washoe County, “may” is permissive and “shall” or “must” is mandatory.

Conditions of approval are usually complied with at different stages of the proposed project. Those stages are typically:

- Prior to permit issuance (i.e., grading permits, building permits, etc.).
- Prior to obtaining a final inspection and/or a certificate of occupancy.
- Prior to the issuance of a business license or other permits/licenses.
- Some “conditions of approval” are referred to as “operational conditions.” These conditions must be continually complied with for the life of the project or business.

The Washoe County Commission oversees many of the reviewing agencies/departments with the exception of the following agencies.

- **The DISTRICT BOARD OF HEALTH, through the Washoe County Health District, has jurisdiction over all public health matters in the Health District. Any conditions set by the Health District must be appealed to the District Board of Health.**

FOLLOWING ARE CONDITIONS OF APPROVAL REQUIRED BY THE REVIEWING AGENCIES. EACH CONDITION MUST BE MET TO THE SATISFACTION OF THE ISSUING AGENCY.

Washoe County Planning and Building Division

- a. The following conditions are requirements of Planning and Building, which shall be responsible for determining compliance with these conditions.

Contact Name – Chris Bronczyk, Senior Planner, 775.328.3612, cbronczyk@washoecounty.gov

- a. **The applicant shall attach a copy of the action order approving this project to all permits and applications (including building permits) applied for as part of this special use permit.**
- b. The applicant shall demonstrate substantial conformance to the plans approved as part of this special use permit.
- c. The applicant shall submit construction plans, with all information necessary for comprehensive review by Washoe County, and initial building permits shall be issued within two years from the date of approval by Washoe County. The applicant shall complete construction within the time specified by the building permits.
- d. A note shall be placed on all construction drawings and grading plans stating:

NOTE

Should any cairn or grave of a Native American be discovered during site development, work shall temporarily be halted at the specific site and the Sheriff's Office as well as the State Historic Preservation Office of the Department of Conservation and Natural Resources shall be immediately notified per NRS 383.170.

- d. Construction activities shall be limited to the hours between 7am to 7pm, Monday through Saturday only. Any construction machinery activity or any noise associated with the construction activity are also limited to these hours.
- e. Applicant shall restore and/or revegetate disturbed areas using TRPA's approved plant list.

Washoe County Engineering and Capital Projects

2. The following conditions are requirements of the Engineering Division, which shall be responsible for determining compliance with these conditions.

GENERAL CONDITIONS

Contact Information: Robert Wimer, P.E. (775) 328-2059

- a. A complete set of construction improvement drawings, including an on-site grading plan, shall be submitted when applying for a building/grading permit. Grading shall comply with best management practices (BMP's) and shall include detailed plans for grading, site drainage, erosion control (including BMP locations and installation details), slope stabilization, and mosquito abatement. Placement or removal of any excavated materials shall be indicated on the grading plan. Silts shall be controlled on-site and not allowed onto adjacent property.
- b. The developer shall obtain from the Nevada Division of Environmental Protection a Stormwater Discharge Permit or Waiver for construction and submit a copy to the Engineering Division prior to issuance of a grading permit.

- c. The developer shall complete and submit the Construction Permit Submittal Checklist and pay the Construction Stormwater Inspection Fee prior to obtaining a grading permit. The County Engineer shall determine compliance with this condition.
- d. Applicant shall indicate on the plans where exported materials will be taken and a grading permit shall be obtained for the import site.
- e. Exported materials shall not be sold without the proper business license.
- f. Cross-sections indicating cuts and fills shall be submitted when applying for a grading permit. Estimated total volumes shall be indicated.
- g. All disturbed areas left undeveloped for more than 30 days shall be treated with a dust palliative. Disturbed areas left undeveloped for more than 45 days shall be revegetated. Methods and seed mix must be approved by the County Engineer with technical assistance from the Washoe-Storey Conservation District. The applicant shall submit a revegetation plan to the Washoe-Storey Conservation District for review.
- h. Slopes steeper than 3H:1V shall be justified through a geotechnical report prepared by a Licensed Engineering in the State of Nevada.

DRAINAGE (COUNTY CODE 110.416, 110.420, and 110.421)

Contact Information: Robert Wimer, P.E. (775) 328-2059

- i. The developer shall provide pretreatment for petrochemicals and silt for all storm drainage from the site to the satisfaction of the County Engineer.
- j. The following note shall be added to the construction drawings; "All properties, regardless if they are located within or outside of a FEMA designated flood zone, may be subject to flooding. The property owner is required to maintain all drainage easements and natural drainages and not perform or allow unpermitted and unapproved modifications to the property that may have detrimental impacts to surrounding properties."

TRAFFIC AND ROADWAY (COUNTY CODE 110.436)

Contact Information: Mitchell Fink, P.E. (775) 328-2050

- k. An approved encroachment permit shall be obtained from the Nevada Department of Transportation (NDOT), for access to, from, or under roads and highways maintained by NDOT and a copy of said permit sent to the Engineering Division prior to building or grading permit approval.

UTILITIES (County Code 422 & Sewer Ordinance)

Contact Information: Alexander Mayorga, P.E. (775) 328-2313

- l. No Conditions.

North Lake Tahoe Fire Protection District

- 3. The following conditions are requirements of the North Lake Tahoe Fire Protection District, which shall be responsible for determining compliance with these conditions.

Contact Name – John James, Fire Marshal, 775.831.0351; jjames@nlfpd.net

- a. The fire hydrant indicated on sheet C1.1 is required and the location may be re-examined with the cooperation and coordination with the proposed project located at 447 Lakeshore Blvd.

- b. The project will be required to be fully sprinklered and a monitored fire alarm system.
- c. NLTFPD highly encourages a heated driveway.

Incline Village General Improvement District (IVGID)

- 4. The following conditions are requirements of the Incline Village General Improvement District. IVGID shall be responsible for determining compliance with these conditions.

Contact Name – Tim Buxton; IVGID Chief Inspector, 775.832.1246; tlb@ivgid.org

- a. The owner of this project has applied for future water and sewer underground utilities for the construction of a new home located at 449 Lakeshore. Those plans are waiting for final approval from NDOT. The owner and its designers need to review this request to determine if any construction of walls could impact the installation of any future IVGID utilities lines to be installed for the construction of 449 Lakeshore.

*** End of Conditions ***



Date: March 20, 2023

To: Chris Bronczyk, Senior Planner

From: Robert Wimer, P.E., Licensed Engineer

Re: Special Use Permit for **449 Lakeshore WSUP23-0009**
APN 123-250-08

GENERAL PROJECT DISCUSSION

Washoe County Engineering staff has reviewed the above referenced application. The Special Use Permit is for the construction of a driveway serving a single family residence and is located on approximately 1.32 acres at the east side of Lakeshore Boulevard, southwest of Incline Village. The Engineering and Capital Projects Division recommends approval with the following comments and conditions of approval which supplement applicable County Code and are based upon our review of the site and the application prepared by Christy Corporation, Ltd. The County Engineer shall determine compliance with the following conditions of approval.

For questions related to sections below, please see the contact name provided.

GENERAL CONDITIONS

Contact Information: Robert Wimer, P.E. (775) 328-2059

1. A complete set of construction improvement drawings, including an on-site grading plan, shall be submitted when applying for a building/grading permit. Grading shall comply with best management practices (BMP's) and shall include detailed plans for grading, site drainage, erosion control (including BMP locations and installation details), slope stabilization, and mosquito abatement. Placement or removal of any excavated materials shall be indicated on the grading plan. Silts shall be controlled on-site and not allowed onto adjacent property.
2. The developer shall obtain from the Nevada Division of Environmental Protection a Stormwater Discharge Permit or Waiver for construction and submit a copy to the Engineering Division prior to issuance of a grading permit.
3. The developer shall complete and submit the Construction Permit Submittal Checklist and pay the Construction Stormwater Inspection Fee prior to obtaining a grading permit. The County Engineer shall determine compliance with this condition.
4. Applicant shall indicate on the plans where exported materials will be taken and a grading permit shall be obtained for the import site.

5. Exported materials shall not be sold without the proper business license.
6. Cross-sections indicating cuts and fills shall be submitted when applying for a grading permit. Estimated total volumes shall be indicated.
7. All disturbed areas left undeveloped for more than 30 days shall be treated with a dust palliative. Disturbed areas left undeveloped for more than 45 days shall be revegetated. Methods and seed mix must be approved by the County Engineer with technical assistance from the Washoe-Storey Conservation District. The applicant shall submit a revegetation plan to the Washoe-Storey Conservation District for review.
8. Slopes steeper than 3H:1V shall be justified through a geotechnical report prepared by a Licensed Engineering in the State of Nevada.

DRAINAGE (COUNTY CODE 110.416, 110.420, and 110.421)

Contact Information: Robert Wimer, P.E. (775) 328-2059

1. The developer shall provide pretreatment for petrochemicals and silt for all storm drainage from the site to the satisfaction of the County Engineer.
2. The following note shall be added to the construction drawings; "All properties, regardless if they are located within or outside of a FEMA designated flood zone, may be subject to flooding. The property owner is required to maintain all drainage easements and natural drainages and not perform or allow unpermitted and unapproved modifications to the property that may have detrimental impacts to surrounding properties."

TRAFFIC AND ROADWAY (COUNTY CODE 110.436)

Contact Information: Mitchell Fink, P.E. (775) 328-2050

1. An approved encroachment permit shall be obtained from the Nevada Department of Transportation (NDOT), for access to, from, or under roads and highways maintained by NDOT and a copy of said permit sent to the Engineering Division prior to building or grading permit approval.

UTILITIES (County Code 422 & Sewer Ordinance)

Contact Information: Alexander Mayorga, P.E. (775) 328-2313

1. No Conditions.

**WASHOE COUNTY
HEALTH DISTRICT**
ENHANCING QUALITY OF LIFE

February 27, 2023

Washoe County Community Services
Planning and Development Division

RE: 449 Lakeshore; 123-250-08
Special Use Permit; WSUP23-0009

Dear Washoe County Staff:

The following conditions are requirements of the Washoe County Health District, Environmental Health Services Division, (WCHD), which shall be responsible for determining compliance with these conditions.

Contact Name – James English - jenglish@washoecounty.us

- a) Condition #1: The WCHD has reviewed the above referenced project and has no objections to the approval of the application as submitted for grading, setbacks and excavation.
- b) Condition #2: It is noted the subject property is served by community water and sewerage systems.

If you have any questions or would like clarification regarding the foregoing, please contact James English, EHS Supervisor at jenglish@washoecounty.us regarding all Health District comments.

Sincerely,

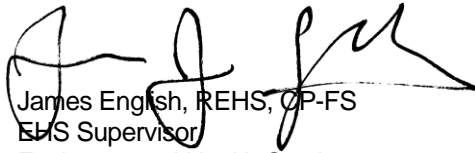

James English, REHS, CP-FS
EHS Supervisor
Environmental Health Services
Washoe County Health District



Date	3-21-23
Attention	Chris Bronczyk
Re	WSUP23-0009
APN	123-250-08
Service Address	449 Lakeshore
Owner	Mysers Family Trust

5. Special Use Permit Case Number WSUP23-0009 (449 Lakeshore) – For hearing, discussion, and possible action to approve a special use permit to allow for a driveway to traverse a slope of thirty (30) percent or greater; to construct a permanent earthen structure greater than 4.5 feet in height within the required front yard setback; excavation of 1,000 cubic yards on slopes greater than 15%; grading of one-half (0.5) acre (21,780 sf) or more on parcels less than six acres in size. The proposal is also requesting to vary standards

found in Washoe County Code (WCC) Section 110.438.45 (a) to allow slopes in excess of, or steeper than three horizontal to one vertical (3:1) and WCC Section 110.438.45 (d) to allow retaining walls taller than an one-half (4.5) feet within the front yard setback.

- Applicant / Owner: Myers Family Trust
- Location: 449 Lakeshore Blvd
- Assessor's Parcel Number(s): 123-250-08
- Parcel Size: 1.32 acres
- Master Plan Category: Suburban Residential (SR)
- Regulatory Zone: Medium Density Suburban (MDS)
- Area Plan: Tahoe
- Development Code: Authorized in Article 810, Special Use Permits
- Commission District: 1 – Commissioner Hill
- Staff: Chris Bronczyk, Senior Planner
Washoe County Community Services Department
Planning and Building Division
- Phone: 775-328-3612
- E-mail: cbronczyk@washoecounty.gov

IVGID Comments: The owner of this project has applied for future water and sewer underground utilities for the construction of a new home located at 449 Lakeshore. Those plans are waiting for final approval from NDOT. The owner and its designers need to review this request to determine if any construction of walls could impact the installation of any future IVGID utilities lines to be installed for the construction of 449 Lakeshore.

From: [John James](#)
To: [Bronczyk, Christopher](#)
Subject: RE: March Agency Review Memo Item 5
Date: Tuesday, March 21, 2023 11:39:40 AM
Attachments: [image006.png](#)

[**NOTICE:** This message originated outside of Washoe County -- **DO NOT CLICK** on **links** or open **attachments** unless you are sure the content is safe.]

Hello Chris,

Yes – Please update the comments to read In regard to WSUP20-0022 (449 Lakeshore Dr.)

1. As previously determined, the fire hydrant indicated on sheet C1.1 is required.
2. Additionally, this project will be required to be fully sprinklered, a monitored fire alarm system and NLTFPD highly requires a heated driveway.



John James
Fire Marshal
Office: [775.831.0351](tel:775.831.0351) x8131 | Cell: [775.413.9344](tel:775.413.9344)
Email: jjames@nltfpd.net
[866 Oriole Way | Incline Village | NV 89451](#)



From: Bronczyk, Christopher <CBronczyk@washoecounty.gov>
Sent: Tuesday, March 21, 2023 11:33 AM
To: John James <jjames@nltfpd.net>
Subject: RE: March Agency Review Memo I

Hi John,

If you have comments or conditions – yes.

If not, then no.

Attached is what I received from Jenn Donohue when this item went through originally. The SUP is a repeat due to expiration and very little appears to have changed.

[Chris Bronczyk](#)
Senior Planner, Planning & Building Division | Community Services Department



Washoe-Storey Conservation District

Bret Tyler Chairmen
Jim Shaffer Treasurer
Cathy Canfield Storey app
Jean Herman Washoe app

1365 Corporate Blvd.
Reno NV 89502
775 857-8500 ext. 131
nevadaconservation.com

December 22, 2020

Washoe County Community Services Department

C/O Chris Bronczyk, Planner

1001 E Ninth Street, Bldg. A

Reno, NV 89512

R: WSUP20- 0022 449 Lakeshore

Dear Chris,

In reviewing the special use permit for a driveway to traverse a slope of 30 percent, the Conservation District amends the October 22nd letter with the following comments.

With TRPA requiring the vegetation plan, please send a copy of this plan to the District for our records for the project.

The District requires below all energy dissipaters for storm water runoff 2 feet by 3 feet infiltration trench to filter water flows to Lake Tahoe.

With 11 native trees removed for the proposed driveway, the District supports TRPA's requirement to mitigate this loss.

If the 1:1 slope is mechanically stabilized, the District will require 3/4 to 1 1/2-inch D size rock in the voids of the rip rap slope to reduce undermining by small animals.

We recommend as a condition the exterior of the building paint color palette be earth tone colors including the roofing material.

Thank you for providing us the opportunity to review the project that may have impacts on our natural resources.

Sincerely,
Tyler-Shaffer

From: [Pekar, Faye-Marie L.](#)
To: [Bronczyk, Christopher](#)
Subject: Parks Comments WSUP23-009 (449 Lakeshore)
Date: Wednesday, March 29, 2023 10:38:59 AM
Attachments: [image001.png](#)

Good Morning Chris,

I have reviewed WSUP23-009 (449 Lakeshore Blvd.) for the driveway grading. I do not have any comments or conditions from Washoe County Parks.

Thank you,



Faye-Marie L. Pekar, MPA
Park Planner, Planning & Building Division | Community Services Department
fpekar@washoecounty.gov |

Visit us first online: www.washoecounty.gov/csd
Planning Division: 775.328.6100 | Planning@washoecounty.gov
CSD Office Hours: Monday-Friday 8:00am to 4:00pm
1001 East Ninth Street, Reno, NV 89512



Have some kudos to share about a Community Services Department employee or experience?
[Submit a Nomination](#)

Hello,

The EMS Program has reviewed the March Agency Review Memo I - Special Use Permit Case Number WSUP23-0009 (449 Lakeshore) - and has no concerns or questions at this time based on the information provided.

Thank you,

Sabrina.

Sabrina Brasuell

Pronouns: she/her

EMS Coordinator | Epidemiology and Public Health Preparedness

Washoe County Health District

sbrasuell@washoecounty.gov | Cell: (775) 830-7118 | Office: (775) 326-6043

1001 E. Ninth St., Bldg. B. Reno, NV 89512



Please take our customer satisfaction survey by clicking [here](#)

From: [Weiss, Timber A.](#)
To: [Bronczyk, Christopher](#)
Cc: [Behmaram, Vahid](#)
Subject: No Water Right comments for Special Use Permit Case Number WSUP23-0009 (449 Lakeshore)
Date: Wednesday, March 29, 2023 4:44:26 PM
Attachments:

Hello,

No water right comments for the grading under Special Use Permit Case Number WSUP23-0009 (449 Lakeshore).

Thank you,



Timber Weiss, PE | Professional Engineer

Engineering & Capital Projects Division | Community Services Department

1001 E. 9th Street, Bldg A Reno, NV 89512

tweiss@washoecounty.gov | Office Voice Mail: 775.954.4626 or 775.433.0769

Visit us first online: www.washoecounty.us/csd

For additional information, email engineering@washoecounty.us or call 775.328.2040



Public Notice

Washoe County Code requires that public notification of Special Use Permit be mailed to a minimum of 30 separate property owners within a minimum 500-foot radius of the subject property a minimum of 10 days prior to the public hearing date. This proposal was noticed within a 1,500-foot radius of the subject property, noticing 69 separate property owners a minimum of 10 days prior to the public hearing date.

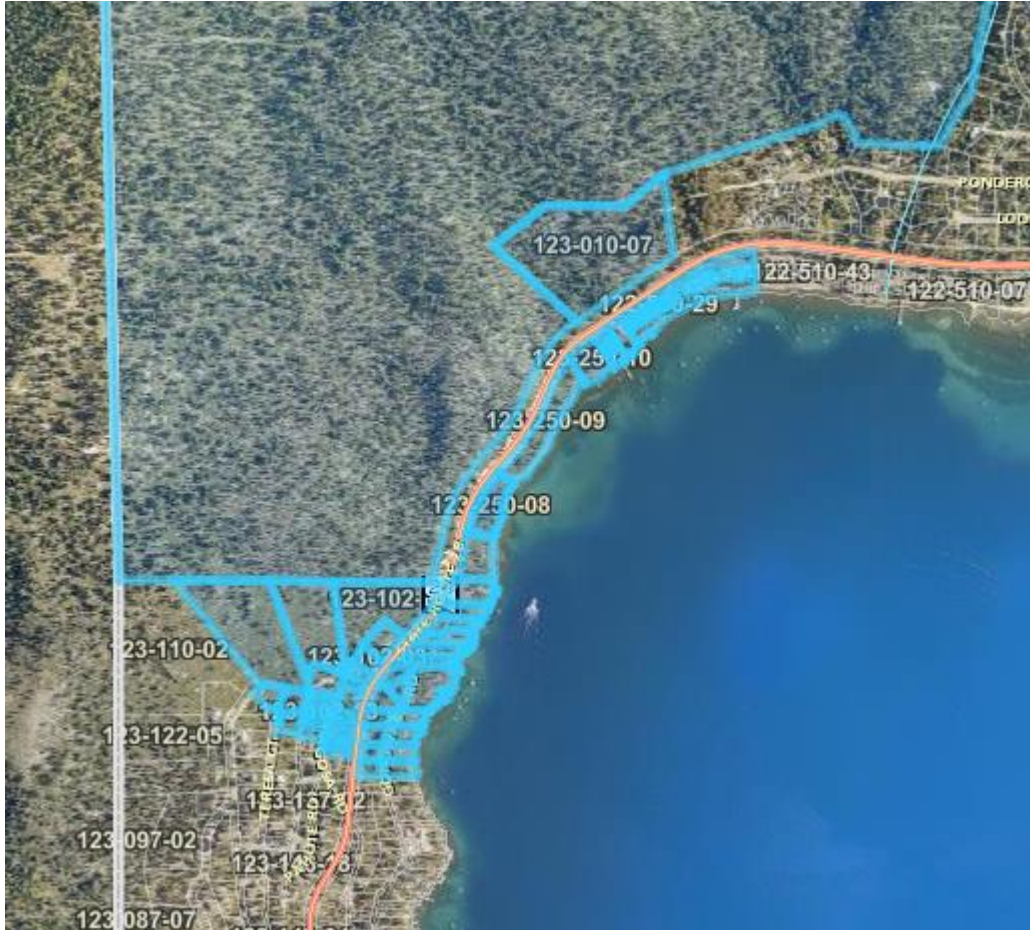

Public Notice Map
Special Use Permit Case Number WSUP23-0009

449 Lakeshore Boulevard Grading Special Use Permit



March 8, 2023

Table of Contents

Introduction	1
Project Location.....	1
Project Background	2
Existing Conditions	2
Project Request	4
Special Use Permit Findings	11

List of Figures:

Figure 1 – Vicinity Map.....	1
Figure 2 – Aerial View.....	2
Figure 3 – Street View	3
Figure 4 – Site Plan	5
Figure 5 – Aerial Site Plan	6
Figure 6 – Typical Slope Stabilization	8
Figure 7 – Typical Wall Sections	9

Appendices:

Washoe County Development Application
Special Use Permit Application

Attachments:

Preliminary Civil Improvement Plans (by others)

449 Lakeshore Boulevard – Grading Special Use Permit

Introduction

This application includes the following request:

- A **Special Use Permit** to allow for grading of a driveway associated with a single family residence.

Project Location

The project site (APN # 123-250-08) consist of 1.32± acres located at 449 Lakeshore Boulevard in Incline Village. Specifically, the subject parcel is located on the shore of Lake Tahoe on the east side of Lakeshore Boulevard (State Route 28), southwest of Incline Village. Figure 1 (below) depicts the project location.

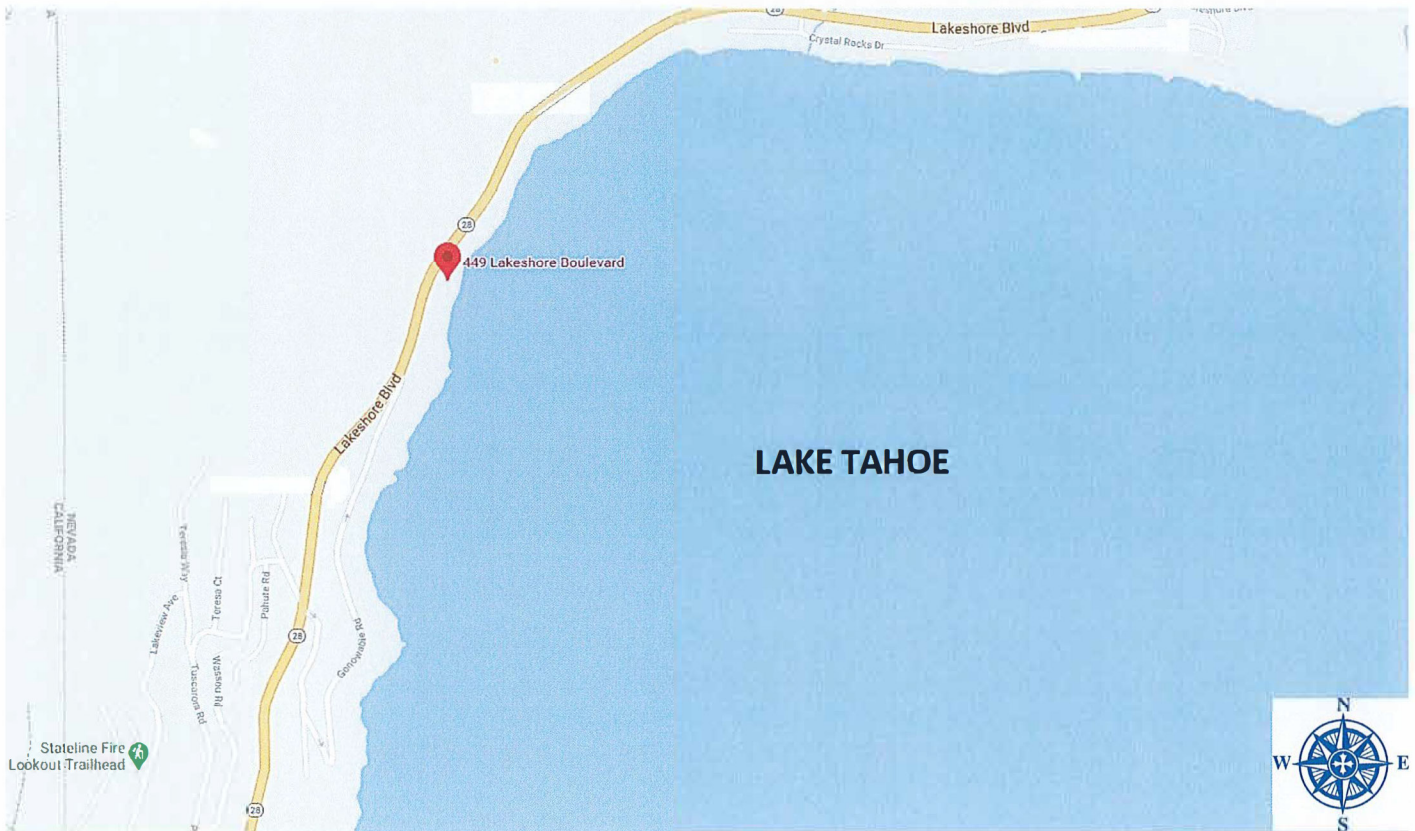

Figure 1 – Vicinity Map

449 Lakeshore Boulevard – Grading Special Use Permit

Project Background

The Washoe County Board of Adjustment approved the SUP request included herein in February 2021. However, due to unforeseen circumstances, construction of the project was delayed. Although the applicant has filed final grading plans/permits with Washoe County, the underlying SUP has expired.

This application simply requests that the approved SUP be reissued. No changes to the plans are proposed, and all applicable permits and approvals referenced in this report (i.e. TRPA, NDOT, etc.) remain valid.

Existing Conditions

The subject property is zoned Medium Density Suburban (MDS) and is currently vacant. The property slopes down from State Route 28 (Lakeshore Boulevard) to the shores of Lake Tahoe on the east side of the site. There is approximately 100± feet of grade differential between the west and east sides of the project site.

Figure 2 (below) provides an aerial overview of the property while Figure 3 (following page) depicts the view of the site from Lakeshore Boulevard.



Figure 2 – Aerial View

449 Lakeshore Boulevard – Grading Special Use Permit



Figure 3 – Street View

449 Lakeshore Boulevard – Grading Special Use Permit

Project Request

As noted previously, this application requests a Special Use Permit (SUP) to allow for driveway grading associated with a planned custom residence. Grading of the proposed driveway will trigger a SUP based on the following Washoe County Development Code criteria (as applied to grading of 15% slopes or greater):

- Section 110.438.35(2)(i)(A) – Grading of one-half (0.5) acre (21,780 square feet) or more on parcels six (6) in size.
- Section 110.438.35(2)(ii)(A) – Excavation of one thousand (1,000) cubic yards or more whether the material is intended to be permanently located on the project site or temporarily stored on a site for relocation to another, final site.
- Section 110.438.35(3) – Any driveway or road that traverses any slope of thirty (30) percent or greater (steeper).
- Section 110.438.35(4) – Grading to construct a permanent earthen structure greater than four and one-half (4.5) feet in height within the required front yard setback, or greater than six (6) feet in height on the remainder of the property. The height of the earthen structure is measured from existing grade at the time of permit issuance.

In addition to the criteria listed above, the SUP also requests that slopes up to 1:1 and increased wall heights be permitted to address the unique site characteristics and reduce onsite grading disturbance.

The proposed driveway will serve a new custom home to be constructed at the south side of the parcel and will connect to Lakeshore Boulevard (State Route 28) at the northern edge of the site. The proposed asphalt driveway will be 14 feet in width and will be gated with a Fire Department accessible gate. The gate is located to allow for stacking of up to 4 vehicles, ensuring that back-ups do not occur along Lakeshore Boulevard.

The proposed driveway widens at the northern end to allow for vehicle turning movements. Specifically, the widened driveway section accommodates a right-turn-in for cars entering the site from northbound lane of Lakeshore Boulevard. Additionally, the flared section allows for the location of a bear proof trash enclosure per Tahoe Regional Planning Agency (TRPA) standards. The driveway also splits as it approaches the proposed home on the south side to serve the split-garage design.

The proposed home and driveway design have been reviewed and approved by TRPA. Since Lakeshore Boulevard is a State Highway (State Route 28), the driveway is also subject to review and approval of the Nevada Department of Transportation (NDOT). As such, the plans presented herein reflect the TRPA approval conditions, as well as applicable NDOT standards. This includes the installation of a fire hydrant at the northern end of the driveway (prior to the entry gate), stormwater treatment/sediment trap facilities, and stormwater energy dissipaters within the project site.

449 Lakeshore Boulevard - Grading Special Use Permit

Figure 4 (below) depicts the project site plan while Figure 5 (following page) provides the site plan in context with an aerial view of the site.

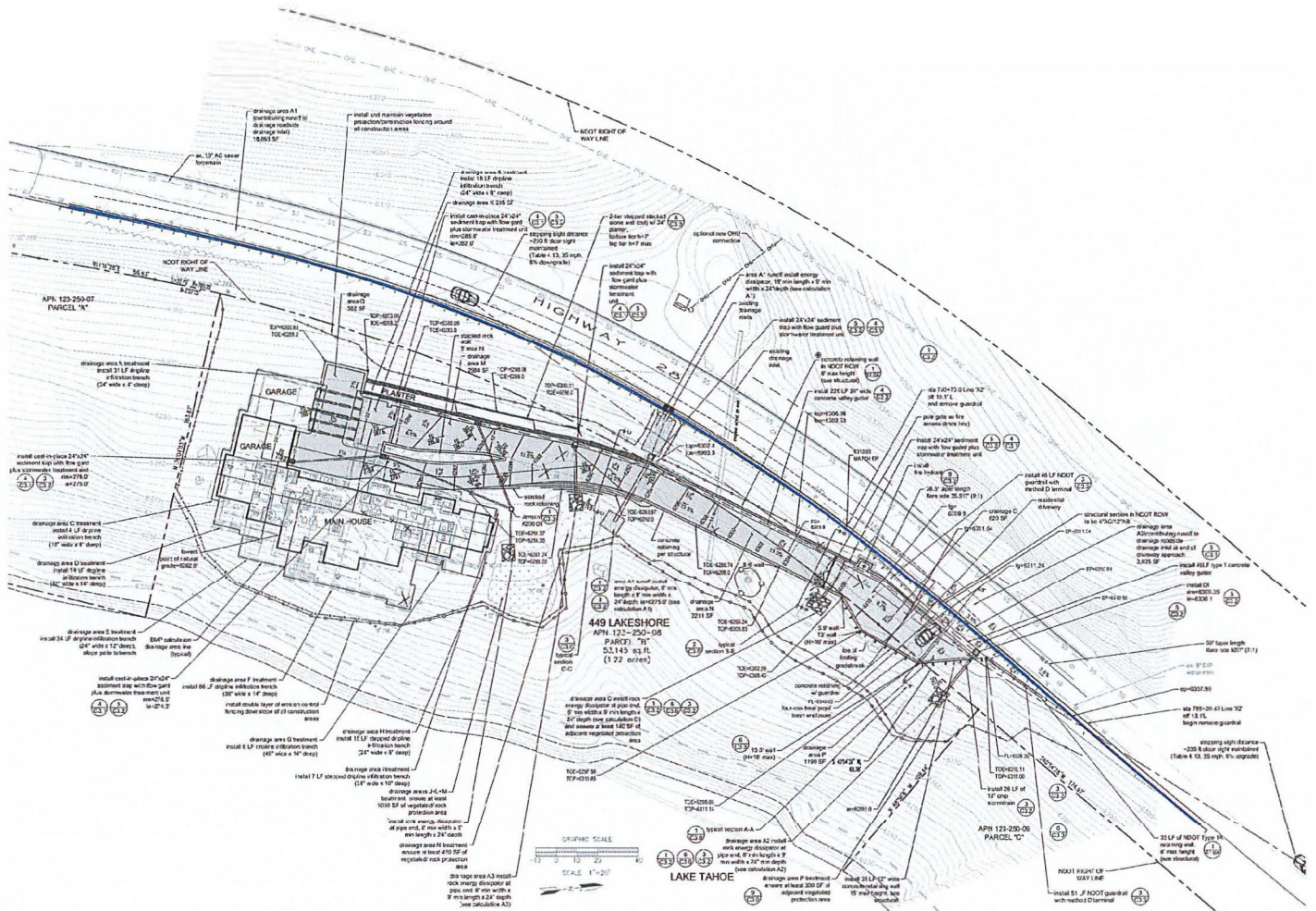

Note: A full size plan is attached.

Figure 4 – Site Plan

449 Lakeshore Boulevard - Grading Special Use Permit

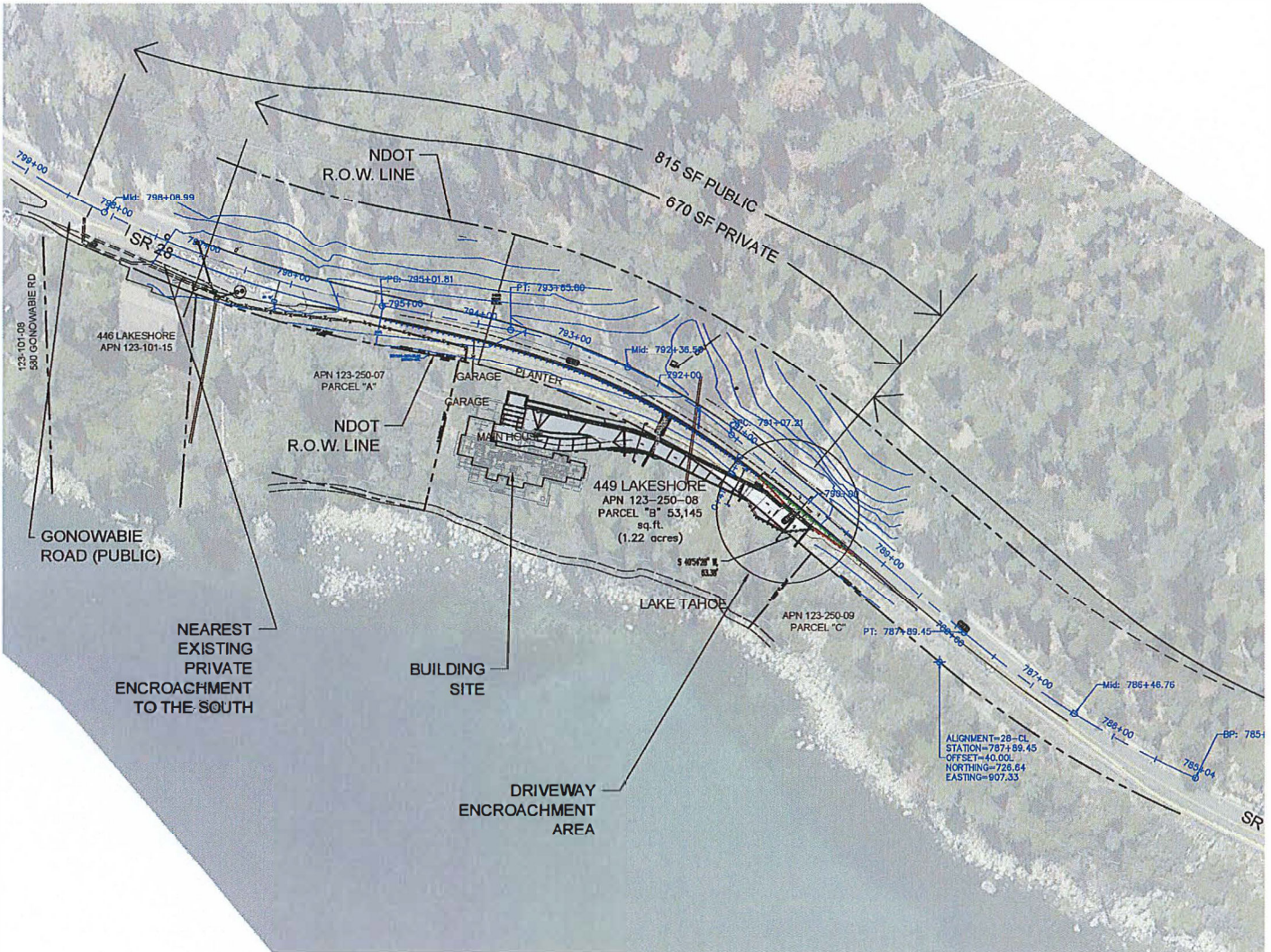

Figure 5 – Aerial Site Plan

449 Lakeshore Boulevard – Grading Special Use Permit

As depicted in Figures 4 and 5, it is proposed to improve the site frontage at the driveway connection to Lakeshore Boulevard in order to accommodate tapers that allow for vehicle deceleration and acceleration in and out of the site, per NDOT standards. Also, the driveway is located to ensure proper sight distance in and out of the driveway along with stopping-sight distance for cars travelling along Lakeshore Boulevard.

As noted previously, the subject property includes up to 100 feet of fall between the east and west sides. The proposed home lies roughly 50± feet below the existing roadway grade. In order to access the home and meet TRPA and NDOT requirements, grading that triggers the SUP thresholds previously noted will need to occur.

Each of the grading criteria previously identified is addressed below:

- Section 110.438.35(2)(i)(A) – Grading of one-half (0.5) acre (21,780 square feet) or more on parcels six (6) in size.

The proposed home and driveway will result in a total disturbed area of approximately 28,380± square feet which meets the threshold of Section 110.438.35(2)(i)(A). The grading is necessary to ensure safe access in and out of the site as well as provide a pad for the house itself. TRPA has reviewed the proposed disturbance in context with their coverage standards, grading and drainage standards, etc. and has approved the plan as presented.

- Section 110.438.35(2)(ii)(A) – Excavation of one thousand (1,000) cubic yards or more whether the material is intended to be permanently located on the project site or temporarily stored on a site for relocation to another, final site.

As proposed and approved by TRPA, there will be approximately 1,398 cubic yards of cut and 766 cubic yards of fill. Excess material will be exported in accordance with the attached grading and drainage plan.

- Section 110.438.35(3) – Any driveway or road that traverses any slope of thirty (30) percent or greater (steeper).

There is 50+ feet of grade separation between the proposed home and Lakeshore Boulevard. The slope from the roadway to the homesite does exceed 30% in some locations. As such, the SUP is included for Section 110.438.35(3) to ensure full compliance with Washoe County Development Code requirements.

- Section 110.438.35(4) – Grading to construct a permanent earthen structure greater than four and one-half (4.5) feet in height within the required front yard setback, or greater than six (6) feet in height on the remainder of the property. The height of the earthen structure is measured from existing grade at the time of permit issuance.

As depicted on the attached grading plan, the improvements associated with the proposed driveway will result in a permanent earthen structure greater than 4.5 feet along Lakeshore Boulevard (front setback). This is a result of the proposed retaining walls as detailed in this report.

449 Lakeshore Boulevard – Grading Special Use Permit

A combination of walls and revegetation will be used to stabilize slopes disturbed as a result of the driveway grading. This includes the use of rockery walls, poured-in-place concrete walls, native revegetation, erosion mats, and formal landscape improvements. Rock walls will not exceed 6-feet in height per the requirements of the Washoe County Development Code. In areas where taller walls are necessitated, the use of poured-in-place concrete walls will occur. By providing taller walls, the overall disturbance is reduced, and a more natural appearance is retained. The concrete walls will be screened through the use of natural vegetation and formal plantings.

Figure 6 (below) depicts the typical slope stabilization methods proposed, while Figure 7 (following page) depicts typical wall sections proposed for 449 Lakeshore Boulevard.

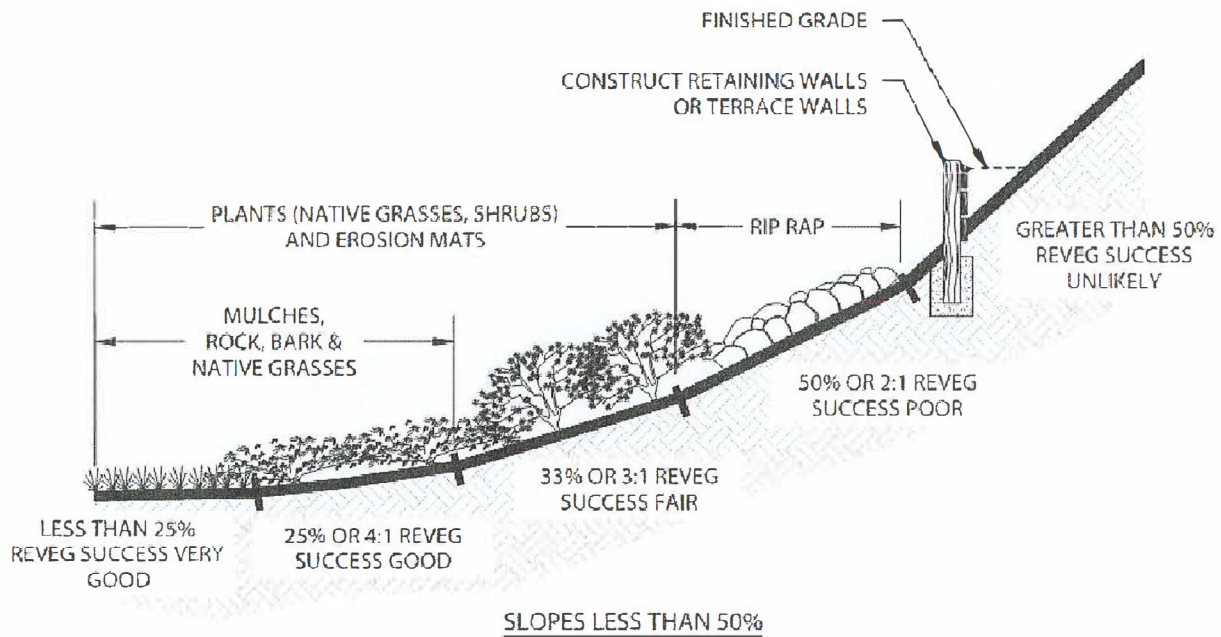

Figure 6 – Typical Slope Stabilization

449 Lakeshore Boulevard – Grading Special Use Permit

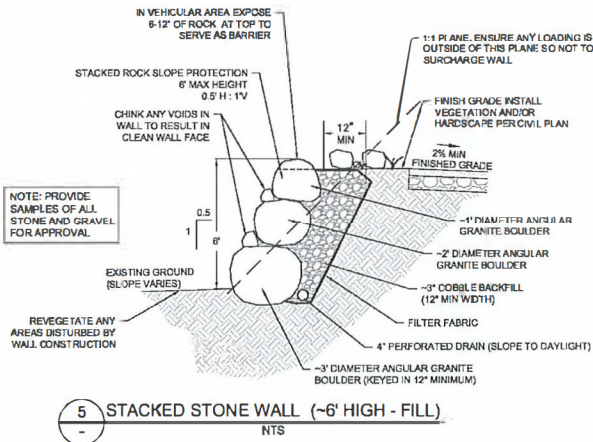
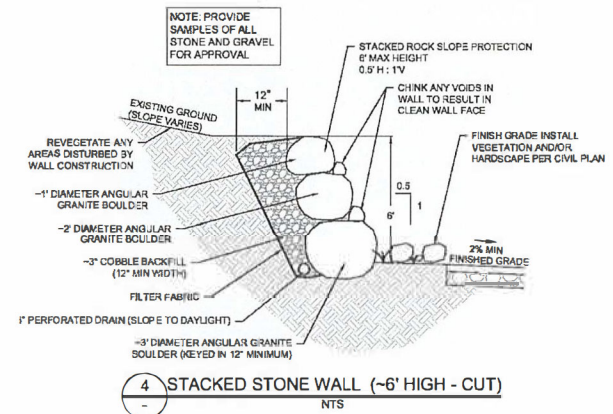
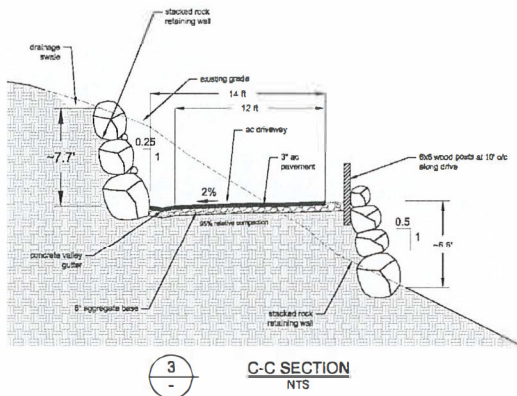
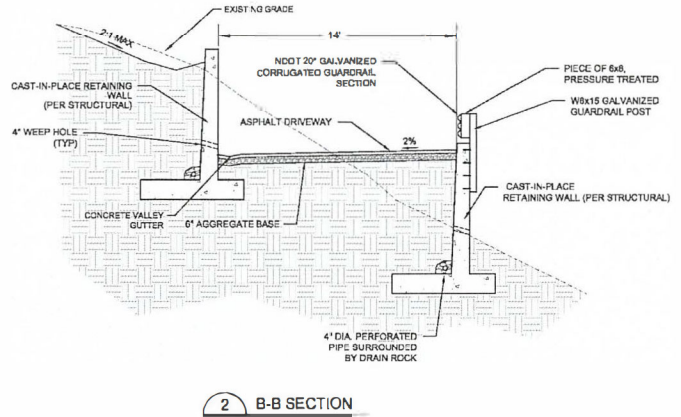
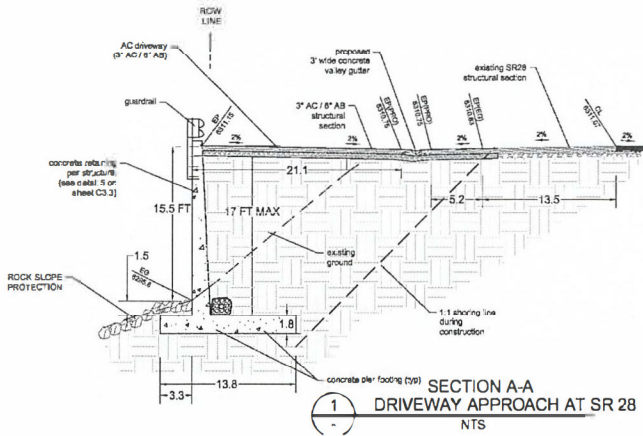

Figure 7 – Typical Wall Sections

449 Lakeshore Boulevard – Grading Special Use Permit

As proposed, the maximum height of concrete walls at 449 Lakeshore Boulevard will be approximately 15.5 feet. The proposed grading, including the walls included as part of this SUP, conform with applicable TRPA standards and plans have already been approved by TRPA.

The project site includes steep terrain between Lakeshore Boulevard and the homesite adjacent to Lake Tahoe. This includes natural 1:1 slope in some locations. The Washoe County Development Code requires that graded slopes be rounded to 3:1 in order to prevent erosion. However, in the case of 449 Lakeshore Boulevard, 3:1 slopes would result in massive scarring and does not meet the stringent standards implemented by TRPA. Thus, this SUP requests that slopes up to 1:1 be permitted in order to match the natural topography of the site. The slopes will be stabilized through the use of walls, erosion mats, revegetation, and landscaping, as depicted on the attached plans. Furthermore, the grading and stabilization methods comply with stringent TRPA standards and have been reviewed and approved by TRPA.

By incorporating the use of walls, landscaping, and slopes proposed, disturbance of the site will be significantly reduced. It is anticipated that the new home will largely screen graded areas and that revegetation will ensure a natural appearance of graded slopes, as viewed from Lake Tahoe. Figure 8 (below) depicts a photo simulation of the developed site, as completed by the project architect.



Figure 8 – Photo Simulation

449 Lakeshore Boulevard – Grading Special Use Permit

Special Use Permit Findings

In order to approve a Special Use Permit, the following findings must be made. Responses are provided in **bold**.

1. Consistency. The granting of the special use permit is consistent with the policies and maps of the Comprehensive Plan Elements and the Area Plan in which the property is located.

The proposed use to be accommodated by the planned grading are permitted within the Medium Density Suburban zone and are consistent with the goals and policies of the Tahoe Area Plan. This SUP request provides for consistency with section 110.438.35 and application of Development Code standards further ensures consistency with all applicable policies, etc.

2. Adequate Public Facilities. Adequate utilities, roadway improvements, sanitation, water supply, drainage, and other necessary facilities must exist or will be provided.

All necessary infrastructure and services necessitated by the proposed residence are in place or will be extended at the expense of the developer. The project will connect with existing municipal water and sewer infrastructure. The proposed driveway encroachment will be reviewed by NDOT for a required encroachment permit. Grading and drainage plans have already been reviewed and approved by TRPA.

3. Site Suitability. The site must be physically suitable for the proposed use and for the intensity of development.

The proposed grading, homesite location, and associated improvements comply with TRPA standards for coverage, grading, site disturbance, tree removal, etc. TRPA standards are some of the most stringent in the nation in terms of environmental protection. The grading proposed, including the use of walls and erosion control measures, will result in minimal disturbance and allow for a natural post-development appearance.

4. Issuance Not Detrimental. Issuance of the permit may not be significantly detrimental to the public health, safety or welfare; have a detrimental impact on adjacent properties; or be detrimental to the character of the surrounding area.

No negative impacts are anticipated with the granting of this SUP request. All potential impacts will be properly mitigated, and the development proposed is directly consistent with surrounding parcels and uses.

APPENDICES

Community Services Department

Planning and Building

SPECIAL USE PERMIT

(see page 7)

SPECIAL USE PERMIT FOR GRADING

(see page 9)

SPECIAL USE PERMIT FOR STABLES

(see page 12)

APPLICATION



Community Services Department
Planning and Building
1001 E. Ninth St., Bldg. A
Reno, NV 89512-2845

Telephone: 775.328.6100

Washoe County Development Application

Your entire application is a public record. If you have a concern about releasing personal information, please contact Planning and Building staff at 775.328.6100.

Project Information		Staff Assigned Case No.: _____	
Project Name: 449 Lakeshore Boulevard Grading SUP			
Project Description: A SUP to allow for grading of a private driveway per Section 110.438.35 of the Washoe County Development Code.			
Project Address: 449 Lakeshore Blvd. Incline Village, NV 89451			
Project Area (acres or square feet): 57,323 square feet			
Project Location (with point of reference to major cross streets AND area locator): The site is located on the east side of Lakeshore Blvd., southwest of Incline Village (refer to attached map).			
Assessor's Parcel No.(s):	Parcel Acreage:	Assessor's Parcel No.(s):	Parcel Acreage:
123-250-08	1.32 acres		
Indicate any previous Washoe County approvals associated with this application: Case No.(s).			
Applicant Information (attach additional sheets if necessary)			
Property Owner:		Professional Consultant:	
Name: Myers Family Trust		Name: Christy Corporation, Ltd.	
Address: 565 Country Club Dr.		Address: 1000 Kiley Pkwy.	
Incline Village, NV	Zip: 89451	Sparks, NV	Zip: 89436
Phone: 520-400-4845	Fax:	Phone: 775-502-8552	Fax:
Email: jgm@blackstonedevelopmentgroup.com		Email: mike@christynv.com	
Cell: 520-400-4845	Other:	Cell: 775-250-3455	Other:
Contact Person: Josh Myers		Contact Person: Mike Railey	
Applicant/Developer:		Other Persons to be Contacted:	
Name: Same as Above		Name:	
Address:		Address:	
Zip:		Zip:	
Phone:	Fax:	Phone:	Fax:
Email:		Email:	
Cell:	Other:	Cell:	Other:
Contact Person:		Contact Person:	
For Office Use Only			
Date Received:	Initial:	Planning Area:	
County Commission District:		Master Plan Designation(s):	
CAB(s):		Regulatory Zoning(s):	

**Special Use Permit Application
Supplemental Information**
(All required information may be separately attached)

1. What is the project being requested?

This application requests a SUP to allow for grading of a private driveway, triggering the thresholds of Section 110.438.35. Refer to attached report for a detailed description.

2. Provide a site plan with all existing and proposed structures (e.g. new structures, roadway improvements, utilities, sanitation, water supply, drainage, parking, signs, etc.)

Refer to attached site plan.

3. What is the intended phasing schedule for the construction and completion of the project?

The project will be completed in a single phase.

4. What physical characteristics of your location and/or premises are especially suited to deal with the impacts and the intensity of your proposed use?

The grading proposed, including walls, revegetation, and erosion control mats are specifically designed to address the unique site characteristics. Refer to attached report for a detailed analysis.

5. What are the anticipated beneficial aspects or affects your project will have on adjacent properties and the community?

The project will be designed to complement adjoining properties and homes in the area. Refer to attached report for specifics.

6. What are the anticipated negative impacts or affect your project will have on adjacent properties? How will you mitigate these impacts?

All potential impacts are properly mitigated with the measures proposed. Refer to attached report for details.

7. Provide specific information on landscaping, parking, type of signs and lighting, and all other code requirements pertinent to the type of use being proposed. Show and indicate these requirements on submitted drawings with the application.

Approximatley 1,398 cubic yards of cut and 766 cubic yards of fill.

8. Are there any restrictive covenants, recorded conditions, or deed restrictions (CC&Rs) that apply to the area subject to the special use permit request? (If so, please attach a copy.)

<input type="checkbox"/> Yes	<input checked="" type="checkbox"/> No
------------------------------	--

9. Utilities:

a. Sewer Service	IVGID
b. Electrical Service	NV Energy
c. Telephone Service	AT&T
d. LPG or Natural Gas Service	Southwest Gas
e. Solid Waste Disposal Service	Waste Management
f. Cable Television Service	AT&T, Charter Communications, or satellite providers
g. Water Service	IVGID

For most uses, Washoe County Code, Chapter 110, Article 422, Water and Sewer Resource Requirements, requires the dedication of water rights to Washoe County. Please indicate the type and quantity of water rights you have available should dedication be required.

h. Permit #		acre-feet per year	
i. Certificate #		acre-feet per year	
j. Surface Claim #		acre-feet per year	
k. Other #		acre-feet per year	

Title of those rights (as filed with the State Engineer in the Division of Water Resources of the Department of Conservation and Natural Resources).

Revegetation, walls, and the home itself will serve to screen disturbed areas.
--

10. Community Services (provided and nearest facility):

a. Fire Station	North Lake Tahoe Fire Protection District - Station # 2
b. Health Care Facility	Incline Village Community Hospital
c. Elementary School	Incline Elementary School
d. Middle School	Incline Middle School
e. High School	Incline High School
f. Parks	Lake Tahoe State Park
g. Library	Washoe County - Incline Village Branch
h. Citifare Bus Stop	N/A

**Special Use Permit Application
for Grading
Supplemental Information**
(All required information may be separately attached)

1. What is the purpose of the grading?

The grading will allow for access to a single family residence. Refer to attached report for a detailed description.

2. How many cubic yards of material are you proposing to excavate on site?

Approximatley 1,398 cubic yards of cut and 766 cubic yards of fill.

3. How many square feet of surface of the property are you disturbing?

28,380 +/- square feet.

4. How many cubic yards of material are you exporting or importing? If none, how are you managing to balance the work on-site?

No import of material is proposed. Export may occur if material cannot be placed onsite. Refer to attached engineering plans.

5. Is it possible to develop your property without surpassing the grading thresholds requiring a Special Use Permit? (Explain fully your answer.)

No. Refer to attached report for a detailed analysis.

6. Has any portion of the grading shown on the plan been done previously? (If yes, explain the circumstances, the year the work was done, and who completed the work.)

Not applicable.

7. Have you shown all areas on your site plan that are proposed to be disturbed by grading? (If no, explain your answer.)

Yes. Refer to attached engineering plans.

8. Can the disturbed area be seen from off-site? If yes, from which directions and which properties or roadways?

The disturbed areas will be visible from Lake Tahoe. Refer to attached report for screening details.

9. Could neighboring properties also be served by the proposed access/grading requested (i.e. if you are creating a driveway, would it be used for access to additional neighboring properties)?

Not applicable.

10. What is the slope (horizontal/vertical) of the cut and fill areas proposed to be? What methods will be used to prevent erosion until the revegetation is established?

Slope varies from 15% to 50% +/-/. The use of walls and erosion mats will be implemented per TRPA standards. Refer to attached report and plans for further specifics.

11. Are you planning any berms?

YesX	No	If yes, how tall is the berm at its highest? Refer to attached plan.
------	----	--

12. If your property slopes and you are leveling a pad for a building, are retaining walls going to be required? If so, how high will the walls be and what is their construction (i.e. rockery, concrete, timber, manufactured block)?

Refer to attached report and plans for a detailed analysis.

13. What are you proposing for visual mitigation of the work?

Revegetation, walls, and the home itself will serve to screen disturbed areas.

14. Will the grading proposed require removal of any trees? If so, what species, how many and of what size?

Pine trees will be removed per TRPA approved plans. Refer to attached engineering drawings.

15. What type of revegetation seed mix are you planning to use and how many pounds per acre do you intend to broadcast? Will you use mulch and, if so, what type?

Revegetation mix will be per approved TRPA standards.

16. How are you providing temporary irrigation to the disturbed area?

Temporary irrigation will be provided via a connection to the domestic supply for the home.

17. Have you reviewed the revegetation plan with the Washoe Storey Conservation District? If yes, have you incorporated their suggestions?

Not applicable. The property is subject to TRPA regulations.

18. Are there any restrictive covenants, recorded conditions, or deed restrictions (CC&Rs) that may prohibit the requested grading?

Yes	NoX	If yes, please attach a copy.
-----	-----	-------------------------------

CIVIL GRADING, BMP AND UTILITY PLAN
NDOT COLOR CODED LAYOUT
 449 LAKESHORE
 APN 123-250-08
 WASHOE COUNTY

COMP: _____ DESIGN: _____
 DRAWN: _____ PREPARED: AT _____
 PROJECT #: 17-022
 HORIZONTAL: N/A
 VERTICAL: N/A
 DATE: 3-1-2023

C1.0

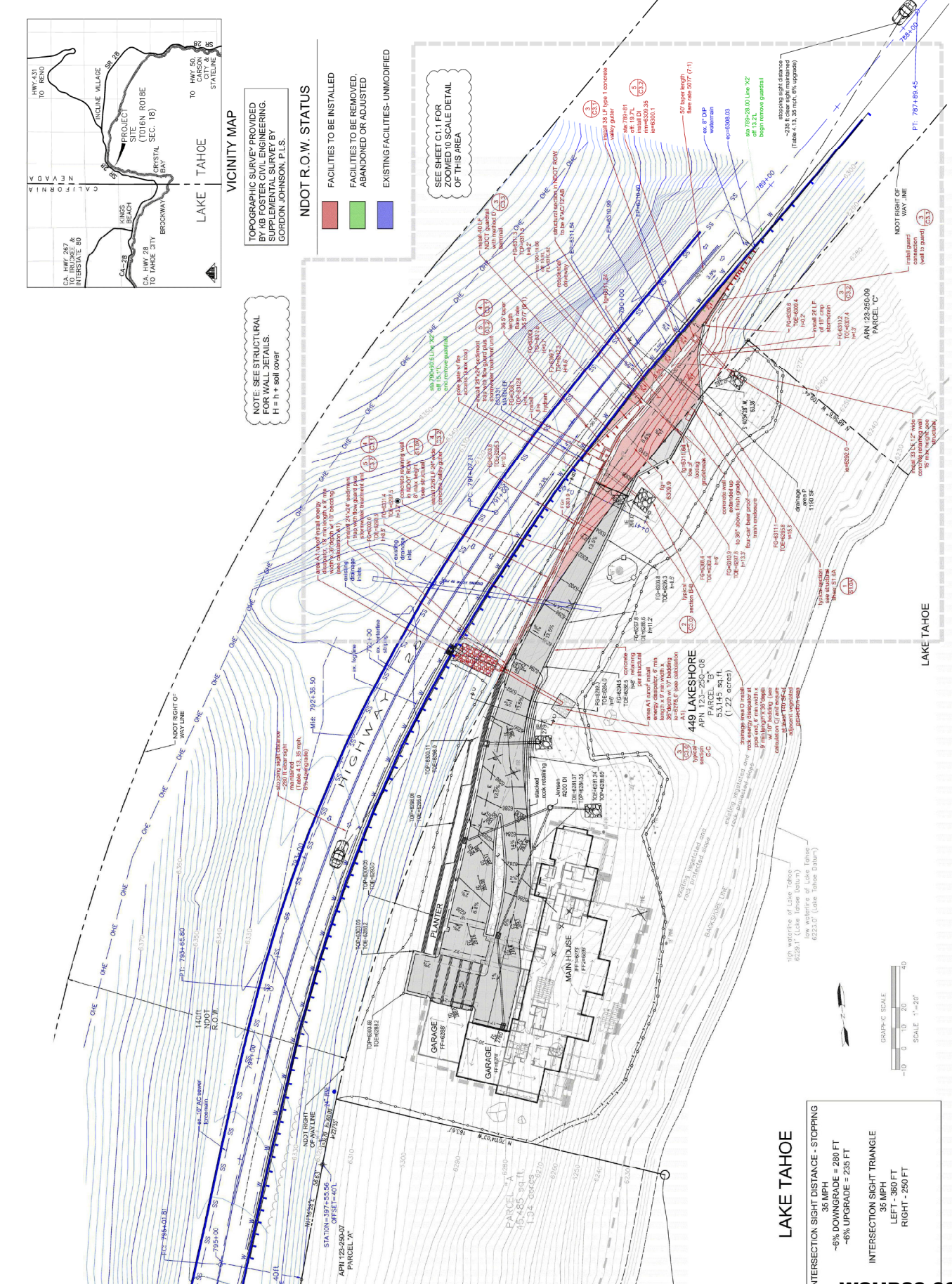

LAKE TAHOE

INTERSECTION SIGHT DISTANCE - STOPPING
 -6% DOWNGRADE = 280 FT
 -6% UPGRADE = 235 FT

INTERSECTION SIGHT TRIANGLE
 35 MPH
 LEFT - 360 FT
 RIGHT - 250 FT

WSUP23-0009
EXHIBIT D

REV.	DATE	DESCRIPTION	APPROVED	DATE

TFI
TRESLAU
 CIVIL
 ENGINEERING, INC.
 1000 S. STATE ST. SUITE 200
 TACOMA, WA 98402
 TEL: 253.408.8485
 FAX: 253.408.8485
 WWW.TRESLAU.COM

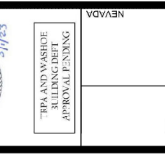

"I, TRESLAU, AS A REGISTERED PROFESSIONAL ENGINEER, HEREBY CERTIFY THAT I AM THE DESIGNER OF THIS PROJECT."
 TRESLAU
 3/1/23

TOPOGRAPHIC SURVEY PROVIDED BY K9 FOSTER CIVIL ENGINEERING. SUPPLEMENTAL SURVEY BY GORDON JOHNSON, P.L.S.

NDOT R.O.W. STATUS

- TO BE INSTALLED
- TO BE REMOVED, ABANDONED OR ADJUSTED
- EXISTING FACILITIES - UNMODIFIED

NOTE: SEE STRUCTURAL FOR WALL DETAILS. FH + 4' soil cover

SEE SHEET C1.1 FOR ZOOMED 10 SCALE DETAIL OF THIS AREA

VICINITY MAP

LAKE TAHOE

TO HWY 50, CARSON STATELINE

TO HWY 431, TO RENO

TO HWY 28, TO TAMBE CITY

TO HWY 267 & INTERSTATE 80

PROJECT SITE (TOTEM ROYBE CRYSTAL SEC. 18)

CL-28

KINGS BEACH

BROCKWAY

INCLINE VILLAGE

CAVANAUGH

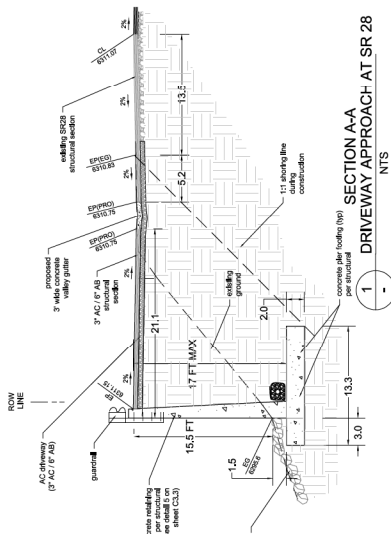

1 SECTION A-A DRIVEWAY APPROACH AT SR 28 NTS

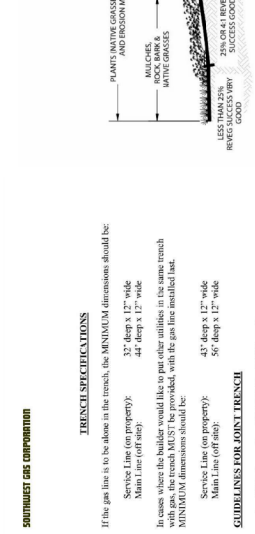

2 SECTION B-B DRIVEWAY APPROACH AT SR 28 NTS

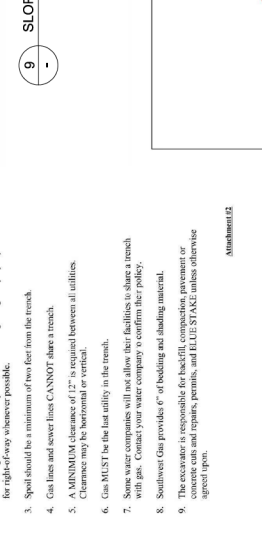

3 SECTION C-C DRIVEWAY APPROACH AT SR 28 NTS

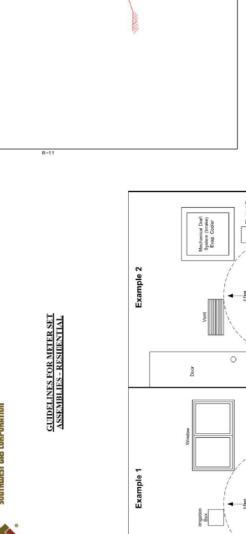

4 STACKED STONE WALL (-6' HIGH - CUT) NTS



5 STACKED STONE WALL (-6' HIGH - FILL) NTS



7 FIRE HYDRANT NTS

6 RIPRAP DITCH NTS

8 GAS SERVICE TRENCH NTS

7 FIRE HYDRANT NTS

6 RIPRAP DITCH NTS

8 GAS SERVICE TRENCH NTS

7 FIRE HYDRANT NTS

6 RIPRAP DITCH NTS

8 GAS SERVICE TRENCH NTS

7 FIRE HYDRANT NTS

6 RIPRAP DITCH NTS

8 GAS SERVICE TRENCH NTS

7 FIRE HYDRANT NTS

6 RIPRAP DITCH NTS

8 GAS SERVICE TRENCH NTS

7 FIRE HYDRANT NTS

6 RIPRAP DITCH NTS

8 GAS SERVICE TRENCH NTS

7 FIRE HYDRANT NTS

6 RIPRAP DITCH NTS

8 GAS SERVICE TRENCH NTS

7 FIRE HYDRANT NTS

6 RIPRAP DITCH NTS

8 GAS SERVICE TRENCH NTS

7 FIRE HYDRANT NTS

6 RIPRAP DITCH NTS

8 GAS SERVICE TRENCH NTS

7 FIRE HYDRANT NTS

6 RIPRAP DITCH NTS

8 GAS SERVICE TRENCH NTS

7 FIRE HYDRANT NTS

6 RIPRAP DITCH NTS

8 GAS SERVICE TRENCH NTS

7 FIRE HYDRANT NTS

6 RIPRAP DITCH NTS

8 GAS SERVICE TRENCH NTS

7 FIRE HYDRANT NTS

6 RIPRAP DITCH NTS

8 GAS SERVICE TRENCH NTS

7 FIRE HYDRANT NTS

6 RIPRAP DITCH NTS

8 GAS SERVICE TRENCH NTS

7 FIRE HYDRANT NTS

6 RIPRAP DITCH NTS

8 GAS SERVICE TRENCH NTS

7 FIRE HYDRANT NTS

6 RIPRAP DITCH NTS

8 GAS SERVICE TRENCH NTS

7 FIRE HYDRANT NTS

6 RIPRAP DITCH NTS

8 GAS SERVICE TRENCH NTS

7 FIRE HYDRANT NTS

6 RIPRAP DITCH NTS

8 GAS SERVICE TRENCH NTS

7 FIRE HYDRANT NTS

6 RIPRAP DITCH NTS

8 GAS SERVICE TRENCH NTS

7 FIRE HYDRANT NTS

6 RIPRAP DITCH NTS

8 GAS SERVICE TRENCH NTS

7 FIRE HYDRANT NTS

6 RIPRAP DITCH NTS

8 GAS SERVICE TRENCH NTS

7 FIRE HYDRANT NTS

6 RIPRAP DITCH NTS

8 GAS SERVICE TRENCH NTS

7 FIRE HYDRANT NTS

6 RIPRAP DITCH NTS

8 GAS SERVICE TRENCH NTS

7 FIRE HYDRANT NTS

6 RIPRAP DITCH NTS

8 GAS SERVICE TRENCH NTS

7 FIRE HYDRANT NTS

6 RIPRAP DITCH NTS

8 GAS SERVICE TRENCH NTS

7 FIRE HYDRANT NTS

6 RIPRAP DITCH NTS

8 GAS SERVICE TRENCH NTS

7 FIRE HYDRANT NTS

6 RIPRAP DITCH NTS

8 GAS SERVICE TRENCH NTS

7 FIRE HYDRANT NTS

6 RIPRAP DITCH NTS

8 GAS SERVICE TRENCH NTS

7 FIRE HYDRANT NTS

6 RIPRAP DITCH NTS

8 GAS SERVICE TRENCH NTS

7 FIRE HYDRANT NTS

6 RIPRAP DITCH NTS

8 GAS SERVICE TRENCH NTS

7 FIRE HYDRANT NTS

6 RIPRAP DITCH NTS

8 GAS SERVICE TRENCH NTS

7 FIRE HYDRANT NTS

6 RIPRAP DITCH NTS

8 GAS SERVICE TRENCH NTS

7 FIRE HYDRANT NTS

6 RIPRAP DITCH NTS

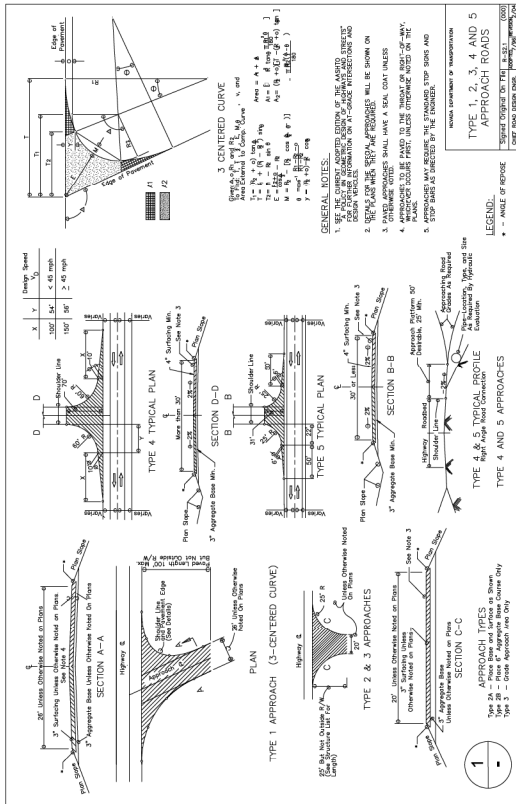

R-1

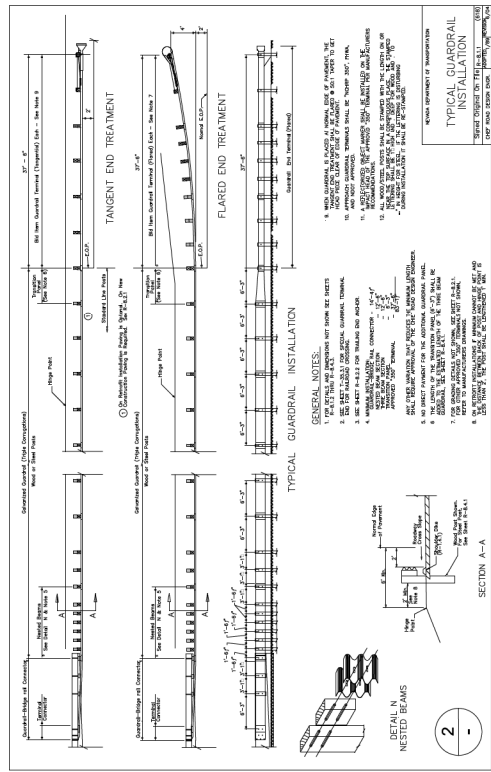

R-69

REV. DATE DESCRIPTION APPROVED DATE

TIESLAU CIVIL ENGINEERING, INC.
1000 W. 10TH STREET
TAMPA CITY, FL 33604
TEL: 813.241.1111
FAX: 813.241.1112
WWW.TIESLAUCIVIL.COM

TRPA AND WASHOE BUILDING DEPT. APPROVAL STAMP

PROJECT # 17-222
HORIZONTAL: N/A
VERTICAL: N/A
DATE: 24-2023

C3.1

CIVIL DETAILS

449 LAKESHORE
APN 123-250-08
WASHOE COUNTY

COMP: DRWN: DESIG: AT

PROJECT # 17-222
HORIZONTAL: N/A
VERTICAL: N/A
DATE: 24-2023

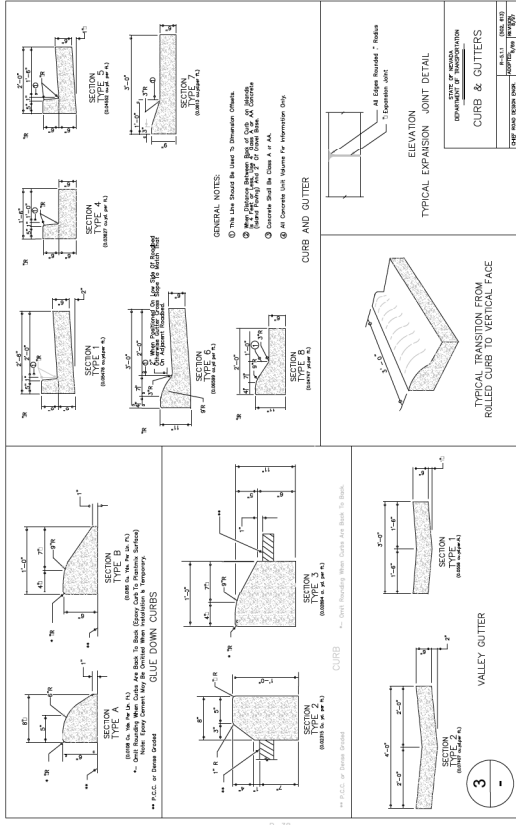

R-35

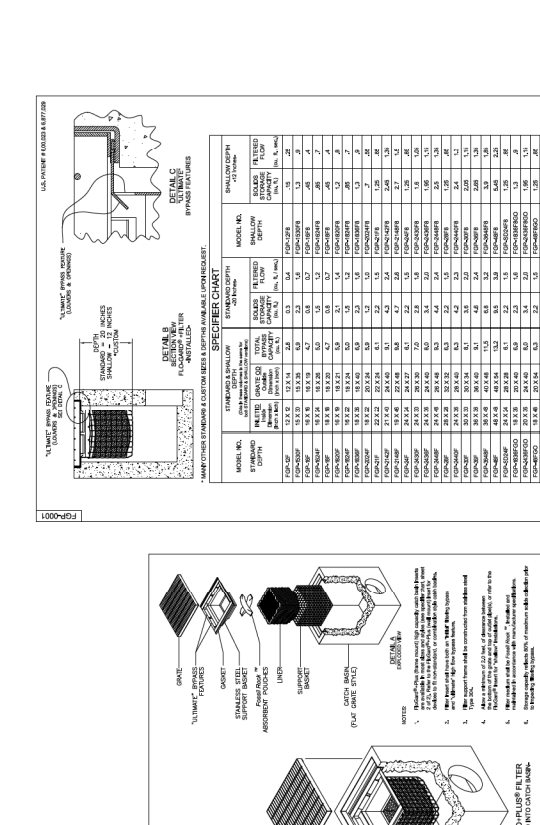

R-35

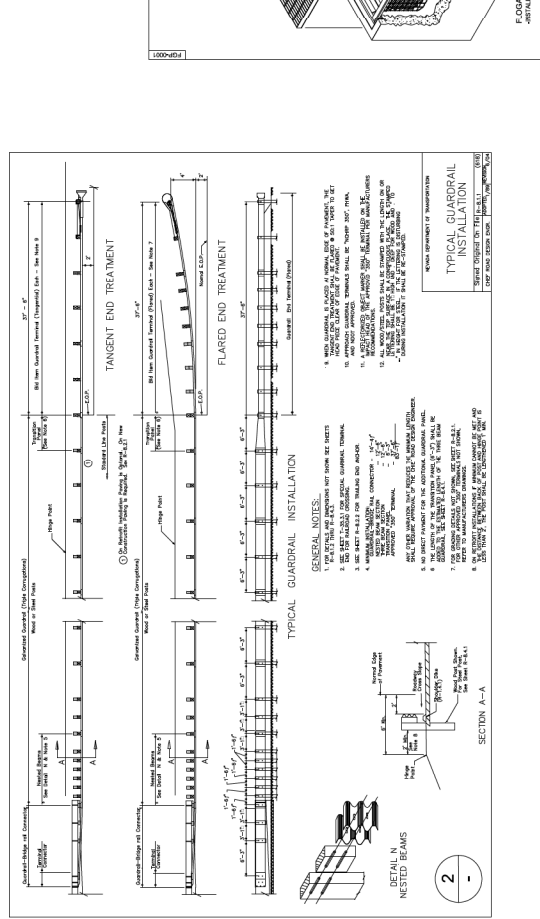

R-35

REV. DATE DESCRIPTION APPROVED DATE

TIESLAU CIVIL ENGINEERING, INC.
1000 W. 10TH STREET
TAMPA CITY, FL 33604
TEL: 813.241.1111
FAX: 813.241.1112
WWW.TIESLAUCIVIL.COM

TRPA AND WASHOE BUILDING DEPT. APPROVAL STAMP

REV. DATE DESCRIPTION APPROVED DATE

TIESLAU CIVIL ENGINEERING, INC.
1000 W. 10TH STREET
TAMPA CITY, FL 33604
TEL: 813.241.1111
FAX: 813.241.1112
WWW.TIESLAUCIVIL.COM

TRPA AND WASHOE BUILDING DEPT. APPROVAL STAMP

REV. DATE DESCRIPTION APPROVED DATE

TIESLAU CIVIL ENGINEERING, INC.
1000 W. 10TH STREET
TAMPA CITY, FL 33604
TEL: 813.241.1111
FAX: 813.241.1112
WWW.TIESLAUCIVIL.COM

TRPA AND WASHOE BUILDING DEPT. APPROVAL STAMP

REV. DATE DESCRIPTION APPROVED DATE

TIESLAU CIVIL ENGINEERING, INC.
1000 W. 10TH STREET
TAMPA CITY, FL 33604
TEL: 813.241.1111
FAX: 813.241.1112
WWW.TIESLAUCIVIL.COM

TRPA AND WASHOE BUILDING DEPT. APPROVAL STAMP

