

**HILL PLANNING, Inc.**  
**P.O. Box 6139 Incline Village, NV 89450**  
**Phone (775) 832-5235 Cell (775)544-4345**  
**e-mail: [tahoehills@att.net](mailto:tahoehills@att.net)**

**MEMO**

---

**Date:** August 9, 2021

**HAND DELIVERED**

**To:** Mojra Hauenstein, Director of Planning and Building

**CC:** Karen Nichols, Red Carpet Events

**From:** Kristina Hill, Planning Consultant

**Subject:** Hyatt Regency Lake Tahoe, Outdoor Community Event

Red Carpet Events is proposing to host the Entrepreneurs Organization 2021 Alchemy Conference on the cottage green which is just west of the Lone Eagle Grille on the Hyatt property. The dates of the event are October 12-14, 2021. Enclosed please find the above referenced application including the following items (3 copies and 1 electronic pdf file):

- Completed Outdoor Community Event License Permit Application form with notarized signed owner affidavit
- \$400 Filing fee
- Administrative permit application with supplemental information including Proof of Property Tax Payment
- Floor / Seating Plan, Attachment A
- Certificate of Liability Insurance, Attachment B
- Under Canvas Tent Lease Agreement, Attachment C
- Evacuation plan, Attachment D
- Project Description, Attachment E
- Approximately 400 people are anticipated to attend
- Hotel Security and Event Planning Guide, Attachment F
- Tent Structural Calculations, Attachment G

Restroom facilities will be provided at the adjacent restaurant, Lone Eagle Grille.

Tasks to be Completed Prior to Issuance of Permit:

- Call Before You Dig will mark all utilities
- Lumos Engineering will perform the uplift test
- NLTFPD will inspect and sign off
- Washoe Co. inspector will review, sign and issue the permit prior to the event.

Any additional fees will be paid by Red Carpet Events upon request.

**SPECIAL EVENT APPLICATION**  
**Temporary Sales or Services License**

Application date: \_\_\_\_\_

**Applicant Information**

Applicant's name: Red Carpet Events for Hyatt Regency  
Mailing address: 111 Country Club Dr, Incline Village, NV 89451  
Street or PO Box City State Zip code  
Karen Nichols  
Phone: 775 355-1501 (Business) \_\_\_\_\_ (Home) 775-256-1215 (Cell)  
Email: Karen @ redcarpetdmc.com

**Event Information**

Name of Event: The Entrepreneur's Organization 2021 Alchemy Conf.  
Sponsor's Name: Hyatt Regency Lake Tahoe  
Date(s) of Event: October 12-14, 2021

List all dates proposed for the event. Most special event licenses may be issued for 31 calendar days in a year.

Hours of operation: \_\_\_\_\_  
Location of Event: 981-993 Lakeshore Blvd, Incline Village  
Assessor Parcel Number(s): 127-290-02

Will the event be held at a Washoe County Park facility?  Yes  No

(If yes, please contact Regional Parks and Open Space at 823-6500 for reservations)

Description of Event: Refer to Project Description, attached

Are you representing a charitable or a not for profit organization?  Yes  No

If yes, name of organization: \_\_\_\_\_

The primary purpose of the event or activity is:

- Charity fundraising  Group fundraising  
 Program for community benefit  Government activity

Other: Corporate Event

Will an admission fee be charged for your event?  Yes  No

If yes, amount and type of fee(s): \_\_\_\_\_

When will fee be collected?  Pre-sales  At entrance

Approximate number of participants and other persons: 400

Approximate number of customers and spectators: 100

Approximate maximum number of persons on any one day of the event: 500

Approximate number of vehicles to be parked at the event: 0

Parking Facilities: Location 111 Country Club Spaces available \_\_\_\_\_

**Sales and Vendor Information**

Will food and/or beverages be served?  Yes  No *Hyatt catering*  
(all food and beverage vendors must have the appropriate Washoe County Health District permits)

Will alcoholic beverages be served?  Yes  No  
(all intoxicating liquor vendors must be individually licensed with Washoe County Business License)

Will there be live music?  Yes  No

Will amplified sound equipment be used?  Yes  No

Will non-food items (such as t-shirts, posters) be sold?  Yes  No

Will vendors be at your event?  Yes  No

If yes, how many? For profit: \_\_\_\_\_ Not for profit: \_\_\_\_\_

**Vendor List**

*(attach additional sheets if needed)*

*All food and beverage vendors must have an appropriate permit from Washoe County Health District*

Name of Vendor	Type of product sold or services provided

**SPECIAL EVENT APPLICATION**  
**Temporary Sales or Services License**  
**AFFIDAVIT OF PROPERTY OWNERSHIP**  
**and/or PERMISSION TO CONDUCT EVENT**

STATE OF ~~NEW YORK~~ ILLINOIS  
 ) ss:  
 COUNTY OF ~~WASHINGTON~~ COOK

I, CHRISTINA URBANSKI being duly sworn, depose, and say that I am an owner\* of property involved in this temporary sales or services license application and I do hereby:

(check appropriate box)

Affirm that I am an applicant for the proposed temporary sales or services license application and also own the property or properties on which the sales or services will be conducted;

OR

Affirm that I give permission to the applicants for the proposed temporary sales or services license to conduct the sales and services on the following property or properties which I own:

Assessor Parcel Number(s): 127-280-02

Physical Address: 111 Country Club Dr. Incline Village, NV

Signed Ch Urbanski

Subscribed and sworn to before me this 6th day of August, 2021

Marlise L. Pein  
 Notary Public in and for said county and state

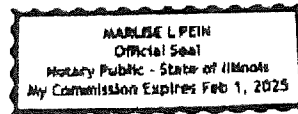

My commission expires: February 1, 2025

\*Owner refers to the following. Please mark the appropriate box.

- OWNER/JOINT OWNER
- CORPORATE OFFICER/PARTNER
- POWER OF ATTORNEY (Provide copy of Power of Attorney)
- AGENT (Attach notarized letter from property owner giving legal authority to agent)
- LETTER FROM GOVERNMENT AGENCY WITH STEWARDSHIP

- 7. **APPROVALS AND AGENCY SIGN-OFFS.** The applicant will be directed to applicable public agencies for approval. This approval will be recorded by the agency on a sign-off list provided to the applicant. These agencies will contact you separately if more information or changes to the application are required. Untimely return of the information or changes to the application may jeopardize license review and approval. Any food vendors, solid waste disposal, and sanitation needs will require separate permits from the Washoe County Health District (775-328-2434). If any reviewing public agencies have any additional application or permit fees, they will so inform you.
- 8. **CONDITIONS OF APPROVAL.** One or more of the reviewing public agencies may recommend conditions be attached to the temporary sales or services license. Washoe County Business License will determine which conditions are attached to the license, and issue the license with those conditions. All conditions must be met to the satisfaction of the imposing public agency, and it is the applicant's responsibility to contact the agency for condition compliance. Failure to comply with any pre-event conditions may cause Washoe County to not issue the temporary sales or services license. Failure to comply with during-event conditions may cause Washoe County to take appropriate measures to revoke or suspend the license. Failure to comply with post-event conditions may cause Washoe County to impose more stringent conditions on, or potentially jeopardize the approval of, future temporary sales or services license applications.
- 9. **ISSUANCE OF LICENSE.** The temporary sales or services license will be issued after all fees have been paid and all necessary approvals, with or without recommended conditions, have been received from reviewing public agencies. The temporary sales or services license receipt demonstrates proof of payment and acts as the temporary sales or service license, if the applicant does not receive the printed Washoe County temporary sales or services license. The license will be sent to the applicant by Email as an attached file. If an Email address is not provided in the application, the license will be sent through U.S. Postal Mail to the applicant's mailing address. **The license or receipt must be displayed prominently at the event and must be available for inspection.** The license is valid only for the temporary sales or services as contained in this application and approved/issued by Washoe County Business License, and not for any other event or location.

All applications must be signed and dated below by the applicant. By signature, the applicant attests an understanding of the application submittal requirements as contained in the General Procedures; understands that conditions may be attached to the temporary sales or services license and will comply with all imposed conditions; and, will not set up nor sell/provide services or products until the temporary sales or services license is approved and issued.

Karen Nichols  
(signature)

Karen Nichols  
(printed name)

Date: 8/7/21

## OUTDOOR COMMUNITY EVENT LICENSE GENERAL PROCEDURES

**Definition:** "Outdoor community event" means an assembly of more than 100 and less than 1,000 persons on any one day of the event gathered together for any purpose, at any location, other than a permanent building or permanent installation that has been constructed for and will accommodate the number of persons gathered therein.

1. **APPLICATION.** Complete the form in ink. This application is for events with attendance over 100 and less than 1,000 persons on any one day the event. There is a \$50.00 nonrefundable application fee. Applications will be returned if the application fee is not included. Three paper copies of the application and one electronic pdf file (memory stick or DVD) must be turned in at least 90 days before the event. The application must include all required forms.
2. **APPLICATION DEADLINE.** All applications must be submitted at least 90 days in advance of the event.
3. **LICENSING/PERMIT REQUIREMENTS.** An outdoor community event license is required on any public or private lands in the unincorporated area of Washoe County except for lands managed by the Washoe County Parks Department and state, trust, tribal, and federal lands. All events must meet land use/regulatory zone requirements before the license will be issued. For information on land use/regulatory zone requirements, call (775) 328-6100 with the parcel number(s) of the event. There are special application processes, depending on the size of the event:
  - a. *Events with between 100 and 299 people on any one day of the event.* These events require an outdoor community event license only. The Director of the Planning and Development Division shall approve, approve with conditions, or deny the license.
  - b. *Events with between 300 and 999 people on any one day of the event.* These events shall obtain both an outdoor community event license and an administrative permit. This application shall suffice for the outdoor community event license application and the administrative permit application. No additional fees are required for filing the administrative permit application. The Board of Adjustment shall approve, approve with conditions, or deny the license and permit.
4. **FEES.** The license fee for an outdoor community event is \$350.00 per day plus any booth fees if applicable. If the event is a carnival, circus or tent show the daily license fee is \$300, to a maximum amount of \$4,200, plus booth fees if applicable.

BOOTH FEES			
1-4 booths	\$ 25	50-59 booths	\$ 300
5-9 booths	\$ 50	60-69 booths	\$ 350
10-19 booths	\$ 100	70-79 booths	\$ 400
20-29 booths	\$ 150	80-89 booths	\$ 450
30-39 booths	\$ 200	90-100 booths	\$ 500
40-49 booths	\$ 250	More than 100 booths	\$ 500 plus \$5 for each booth in excess of 100

5. **INVESTIGATION.** The sheriff's office shall conduct a criminal history background check of the applicants (to include partners and corporate officers). Fingerprint impressions may be taken and submitted to the Nevada central repository for criminal history records and the Federal Bureau of Investigation. Fingerprint impressions will be taken after the application is turned in and deemed complete.
6. **CONDITIONS.** All conditions imposed by the Director or the Board of Adjustment for the outdoor community event license and/or the administrative permit must be met before the license will be issued.
7. **APPROVALS.** The application will be reviewed by the appropriate agencies. The application will be approved by the Director of the Planning and Development Division or the Board of Adjustment.
8. **ISSUANCE OF LICENSE.** The outdoor community event license will be issued after all fees have been paid and all necessary approvals have been received. The event license must be displayed prominently at the event and must be available for inspection. This license is valid only for the event authorized and not for any other event.

## Washoe County Development Application

Your entire application is a public record. If you have a concern about releasing personal information, please contact Planning and Building staff at 775.328.6100.

<b>Project Information</b>		Staff Assigned Case No.: _____	
Project Name: <b>The Entrepreneurs Organization 2021 Alchemy Conference</b>			
Project Description: <b>An outdoor community event on the grass/openspace next to the Lone Eagle Grille, Hyatt Regency Lake Tahoe</b>			
Project Address: <b>981-993 Lakeshore Blvd., Incline Village</b>			
Project Area (acres or square feet): <b>8.561 acres</b>			
Project Location (with point of reference to major cross streets <b>AND</b> area locator): <b>On Lakeshore Blvd. on the lakeside across from the intersection with Country Club Dr.</b>			
Assessor's Parcel No.(s):	Parcel Acreage:	Assessor's Parcel No.(s):	Parcel Acreage:
127-280-02	8.56		
<b>Indicate any previous Washoe County approvals associated with this application:</b> Case No.(s).			
<b>Applicant Information (attach additional sheets if necessary)</b>			
<b>Property Owner:</b>		<b>Professional Consultant:</b>	
Name: <b>Hyatt Regency Lake Tahoe</b>		Name: <b>Red Carpet Events</b>	
Address: <b>993 Lakeshore Blvd.</b>		Address: <b>323 Freeport Blvd.</b>	
Incline Village, NV      Zip: <b>89451</b>		Sparks, NV      Zip: <b>89431</b>	
Phone: <b>775.832.1234</b> Fax:		Phone: <b>775.355.1501</b> Fax:	
Email: <b>mary.clay@hyatt.com</b>		Email: <b>karen@redcarpetdmc.com</b>	
Cell: <b>775.886-6714</b> Other:		Cell: <b>775.250.1215</b> Other:	
Contact Person: <b>Mary Clay</b>		Contact Person: <b>Karen Nichols</b>	
<b>Applicant/Developer:</b>		<b>Other Persons to be Contacted:</b>	
Name: <b>Red Carpet Events</b>		Name:	
Address: <b>see above</b>		Address:	
Zip:		Zip:	
Phone:      Fax:		Phone:      Fax:	
Email:		Email:	
Cell:      Other:		Cell:      Other:	
Contact Person:		Contact Person:	
<b>For Office Use Only</b>			
Date Received:      Initial:		Planning Area:	
County Commission District:		Master Plan Designation(s):	
CAB(s):		Regulatory Zoning(s):	

**Administrative Permit Application  
Supplemental Information**  
(All required information may be separately attached)

1. What is the type of project or use being requested?

Outdoor community event

2. What section of the Washoe County code requires the Administrative permit required?

Sec. 808

3. What currently developed portions of the property or existing structures are going to be used with this permit?

The area to be used for the event is the grass/open space adjacent to the Lone Eagle Grille.

4. What improvements (e.g. new structures, roadway improvements, utilities, sanitation, water supply, drainage, parking, signs, etc.) will have to be constructed or installed and what is the projected time frame for the completion of each?

Tents for shade

5. Is there a phasing schedule for the construction and completion of the project?

The event will be set up Oct. 11, the event will be the 12-14 and will be tore down on the 15th.

6. What physical characteristics of your location and/or premises are especially suited to deal with the impacts and the intensity of your proposed use?

The Hyatt is located on the lakeshore of Lake Tahoe and is experienced with hosting these conferences

7. What are the anticipated beneficial aspects or effect your project will have on adjacent properties and the community?

None

8. What will you do to minimize the anticipated negative impacts or effect your project will have on adjacent properties?

N/A

9. Please describe any operational parameters and/or voluntary conditions of approval to be imposed on the administrative permit to address community impacts.

Limit hours of event.



10. How many improved parking spaces, both on-site and off-site, are available or will be provided? (Please indicate on site plan.)

Parking will be provided by the Hyatt. Approx. 200 spaces will be available to participants as well as valet service.

11. What types of landscaping (e.g. shrubs, trees, fencing, painting scheme, etc.) are proposed? (Please indicate location on site plan.)

None

12. What type of signs and lighting will be provided? On a separate sheet, show a depiction (height, width, construction materials, colors, illumination methods, lighting intensity, base landscaping, etc.) of each sign and the typical lighting standards. (Please indicate location of signs and lights on site plan.)

None

13. Are there any restrictive covenants, recorded conditions, or deed restrictions (CC&Rs) that apply to the area subject to the administrative permit request? (If so, please attach a copy.)

Yes  No

14. Utilities:

a. Sewer Service	IVGID
b. Water Service	IVGID

For most uses, the Washoe County Code, Chapter 110, Article 422, Water and Sewer Resource Requirements, requires the dedication of water rights to Washoe County. Please indicate the type and quantity of water rights you have available should dedication be required:

c. Permit #		acre-feet per year	
d. Certificate #		acre-feet per year	
e. Surface Claim #		acre-feet per year	
f. Other, #		acre-feet per year	

Title of those rights (as filed with the State Engineer in the Division of Water Resources of the Department of Conservation and Natural Resources):

# Property Owner Affidavit

**Applicant Name:** Hyatt Equities, L.L.C.

The receipt of this application at the time of submittal does not guarantee the application complies with all requirements of the Washoe County Development Code, the Washoe County Master Plan or the applicable area plan, the applicable regulatory zoning, or that the application is deemed complete and will be processed.

STATE OF ~~NEW YORK~~ ILLINOIS  
COUNTY OF ~~WASHINGTON~~ COOK

I, CHRISTINA URBANSKI  
(please print name)

being duly sworn, depose and say that I am the owner\* of the property or properties involved in this application as listed below and that the foregoing statements and answers herein contained and the information herewith submitted are in all respects complete, true, and correct to the best of my knowledge and belief. I understand that no assurance or guarantee can be given by members of Planning and Building.

**(A separate Affidavit must be provided by each property owner named in the title report.)**

Assessor Parcel Number(s): 127-280-02

Printed Name CHRISTINA URBANSKI

Signed *Christina Urbanski*

Address 150 N. RIVERSIDE PLAZA,  
CHICAGO, IL 606006

Subscribed and sworn to before me this  
6th day of August, 2021.

*Marlene L. Fein*  
Notary Public in and for said county and state

My commission expires: February 1, 2025

(Notary Stamp)

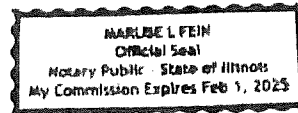

\*Owner refers to the following: (Please mark appropriate box.)

- Owner
- Corporate Officer/Partner (Provide copy of record document indicating authority to sign.)
- Power of Attorney (Provide copy of Power of Attorney.)
- Owner Agent (Provide notarized letter from property owner giving legal authority to agent.)
- Property Agent (Provide copy of record document indicating authority to sign.)
- Letter from Government Agency with Stewardship

PORTION OF N 1/2 SECTION 22  
T16N-R18E

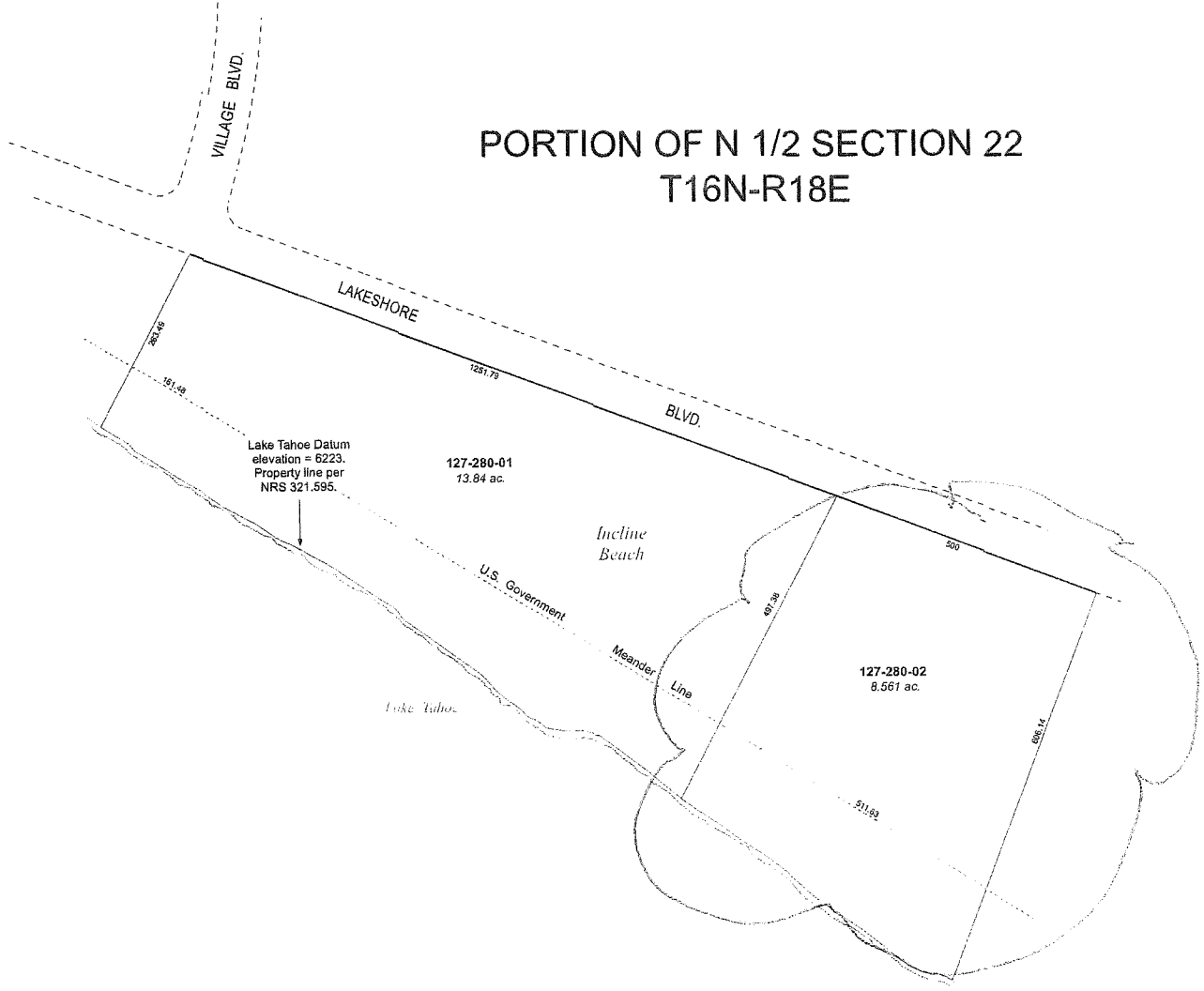

Assessor's Map Number  
**127-28**

STATE OF NEVADA  
**WASHOE COUNTY**  
ASSESSOR'S OFFICE  
Joshua G. Wilson, Assessor

1001 East Niras Street  
Building C  
Reno, Nevada 89512  
(775) 328-2231



Feet  
0 50 100 150 200  
1 inch = 200 feet

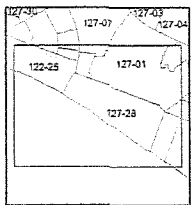
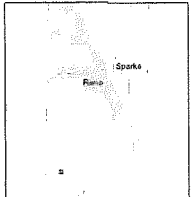

created by: CFB 09/19/2011  
last updated: \_\_\_\_\_  
area previously shown on map(s) \_\_\_\_\_

NOTE: This map was prepared for the use of the Washoe County Assessor for assessment and illustrative purposes only. It does not represent a survey of the premises. No liability is assumed as to the sufficiency or accuracy of the data delineated hereon.

BEACH - NO STRUCTURES HERE

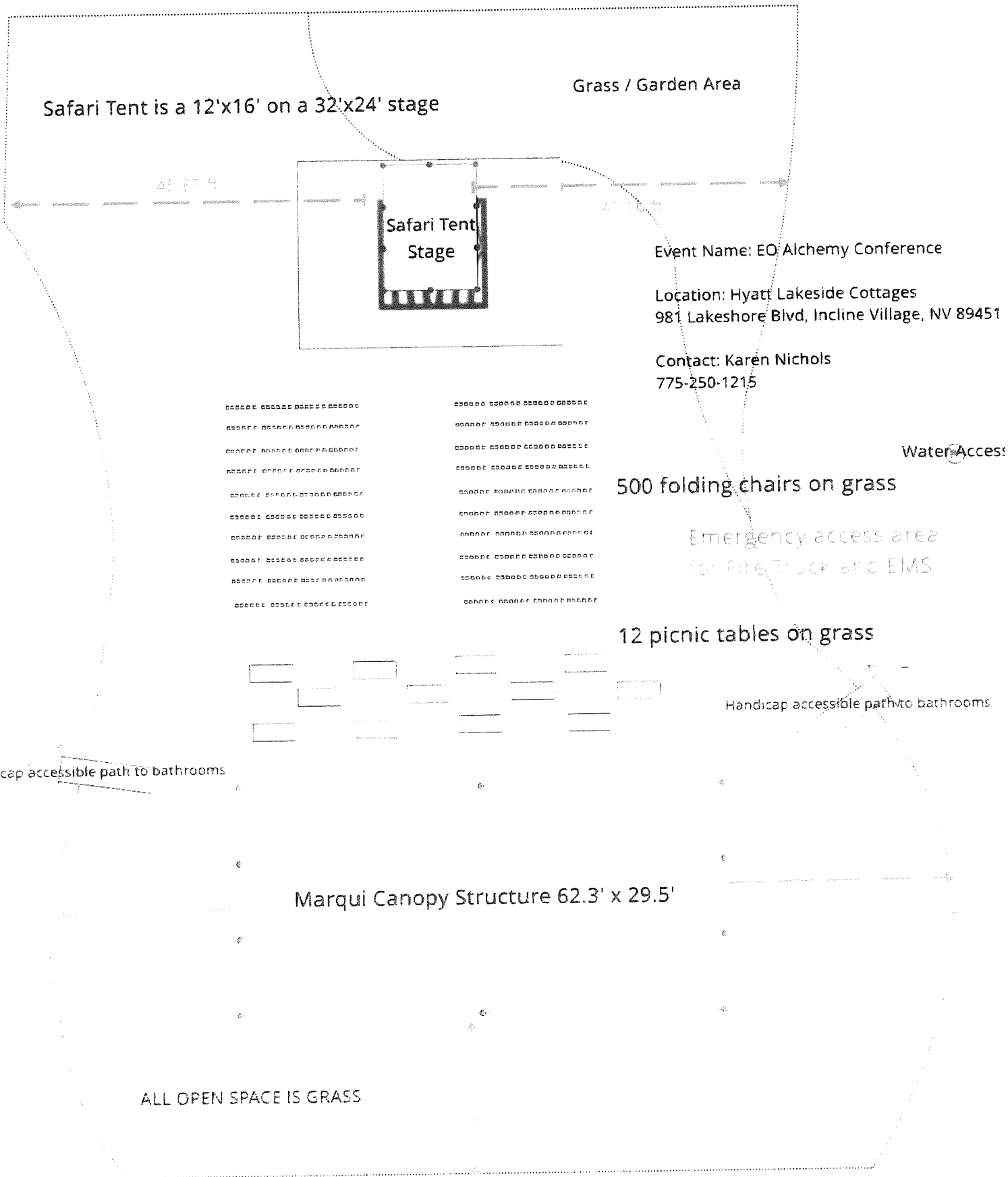

Safari Tent is a 12'x16' on a 32'x24' stage

Grass / Garden Area

45' x 7'

Safari Tent  
Stage

Event Name: EO Alchemy Conference

Location: Hyatt Lakeside Cottages  
981 Lakeshore Blvd, Incline Village, NV 89451

Contact: Karen Nichols  
775-250-1215

Water Access

500 folding chairs on grass

Emergency access area  
for Fire Truck and EMS

12 picnic tables on grass

Handicap accessible path to bathrooms

Handicap accessible path to bathrooms

Marqui Canopy Structure 62.3' x 29.5'

ALL OPEN SPACE IS GRASS

5ft pathway surrounding grass (pathway starting at the dotted lines)

10 Feet

ATTACHMENTS



# CERTIFICATE OF LIABILITY INSURANCE

DATE(MM/DD/YYYY)  
10/20/2020

THIS CERTIFICATE IS ISSUED AS A MATTER OF INFORMATION ONLY AND CONFERS NO RIGHTS UPON THE CERTIFICATE HOLDER. THIS CERTIFICATE DOES NOT AFFIRMATIVELY OR NEGATIVELY AMEND, EXTEND OR ALTER THE COVERAGE AFFORDED BY THE POLICIES BELOW. THIS CERTIFICATE OF INSURANCE DOES NOT CONSTITUTE A CONTRACT BETWEEN THE ISSUING INSURER(S), AUTHORIZED REPRESENTATIVE OR PRODUCER, AND THE CERTIFICATE HOLDER.

**IMPORTANT:** If the certificate holder is an ADDITIONAL INSURED, the policy(ies) must have ADDITIONAL INSURED provisions or be endorsed. If SUBROGATION IS WAIVED, subject to the terms and conditions of the policy, certain policies may require an endorsement. A statement on this certificate does not confer rights to the certificate holder in lieu of such endorsement(s).

<b>PRODUCER</b> Aon Risk Services Central, Inc. Chicago IL Office 200 East Randolph Chicago IL 60601 USA	<b>CONTACT NAME:</b> PHONE (A/C. No. Ext): (866) 283-7122      FAX (A/C. No.): (800) 363-0105		
	<b>E-MAIL ADDRESS:</b>		
<b>INSURED</b> Hyatt Corporation dba Hyatt Regency Lake Tahoe 150 N. Riverside Plaza Chicago IL 60606 USA	<b>INSURER(S) AFFORDING COVERAGE</b>		<b>NAIC #</b>
	INSURER A: National Union Fire Ins Co of Pittsburgh		19445
	INSURER B: Safety National Casualty Corp		15105
	INSURER C: AIU Insurance Company		19399
	INSURER D: New Hampshire Insurance Company		23841
	INSURER E:		
INSURER F:			

**COVERAGES**      **CERTIFICATE NUMBER:** 570084626354      **REVISION NUMBER:**

THIS IS TO CERTIFY THAT THE POLICIES OF INSURANCE LISTED BELOW HAVE BEEN ISSUED TO THE INSURED NAMED ABOVE FOR THE POLICY PERIOD INDICATED. NOTWITHSTANDING ANY REQUIREMENT, TERM OR CONDITION OF ANY CONTRACT OR OTHER DOCUMENT WITH RESPECT TO WHICH THIS CERTIFICATE MAY BE ISSUED OR MAY PERTAIN, THE INSURANCE AFFORDED BY THE POLICIES DESCRIBED HEREIN IS SUBJECT TO ALL THE TERMS, EXCLUSIONS AND CONDITIONS OF SUCH POLICIES. LIMITS SHOWN MAY HAVE BEEN REDUCED BY PAID CLAIMS.      **Limits shown are as requested**

INSR LTR	TYPE OF INSURANCE	ADDL INSD	SUBR WVD	POLICY NUMBER	POLICY EFF (MM/DD/YYYY)	POLICY EXP (MM/DD/YYYY)	LIMITS
A	<input checked="" type="checkbox"/> COMMERCIAL GENERAL LIABILITY <input type="checkbox"/> CLAIMS-MADE <input checked="" type="checkbox"/> OCCUR  GEN'L AGGREGATE LIMIT APPLIES PER: <input checked="" type="checkbox"/> POLICY <input type="checkbox"/> PROJ <input type="checkbox"/> LOC OTHER:			GL5196516	11/01/2020	11/01/2021	EACH OCCURRENCE \$2,000,000 DAMAGE TO RENTED PREMISES (Ea occurrence): \$1,000,000 MED EXP (Any one person) \$5,000 PERSONAL & ADV INJURY \$2,000,000 GENERAL AGGREGATE \$35,000,000 PRODUCTS - COMP/OP AGG Included
A	AUTOMOBILE LIABILITY			CA 2936014	11/01/2020	11/01/2021	COMBINED SINGLE LIMIT (Ea accident) \$3,000,000
A	<input checked="" type="checkbox"/> ANY AUTO <input type="checkbox"/> OWNED AUTOS ONLY <input type="checkbox"/> HIRED AUTOS ONLY <input type="checkbox"/> OTHER:			AOS	11/01/2020	11/01/2021	BODILY INJURY (Per person)
A	<input type="checkbox"/> SCHEDULED AUTOS <input type="checkbox"/> NON-OWNED AUTOS ONLY			CA 2936012 MA CA 2936013 VA	11/01/2020	11/01/2021	BODILY INJURY (Per accident) PROPERTY DAMAGE (Per accident)
	<input type="checkbox"/> UMBRELLA LIAB <input type="checkbox"/> OCCUR <input type="checkbox"/> EXCESS LIAB <input type="checkbox"/> CLAIMS-MADE <input type="checkbox"/> DED <input type="checkbox"/> RETENTION						EACH OCCURRENCE AGGREGATE
C	WORKERS COMPENSATION AND EMPLOYERS' LIABILITY ANY PROPRIETOR, PARTNER, EXECUTIVE OFFICER/MEMBER, EXCLUDED (Mandatory in NH) If yes, describe under DESCRIPTION OF OPERATIONS below:			wc067940270 See Addendum wc067940271 CA	11/01/2020	11/01/2021	<input checked="" type="checkbox"/> PEF STATUTE <input type="checkbox"/> OTHER E.L. EACH ACCIDENT \$1,000,000 E.L. DISEASE-EA EMPLOYEE \$1,000,000 E.L. DISEASE-POLICY LIMIT \$1,000,000
B	Excess WC			SP4063932 See Addendum. SIR applies per policy terms & conditions	11/01/2020	11/01/2021	EL Each Accident \$1,000,000

DESCRIPTION OF OPERATIONS LOCATIONS VEHICLES (ACORD 101. Additional Remarks Schedule. may be attached if more space is required)

## CERTIFICATE HOLDER

## CANCELLATION

Hyatt Regency Lake Tahoe 111 Country Club Drive Incline Village NV 89451 USA	SHOULD ANY OF THE ABOVE DESCRIBED POLICIES BE CANCELLED BEFORE THE EXPIRATION DATE THEREOF, NOTICE WILL BE DELIVERED IN ACCORDANCE WITH THE POLICY PROVISIONS.  AUTHORIZED REPRESENTATIVE  <i>Aon Risk Services Central, Inc.</i>
--	---

©1988-2015 ACORD CORPORATION. All rights reserved.

ACORD 25 (2016/03)

The ACORD name and logo are registered marks of ACORD

ATTACHMENT B

Holder Identifier : TVLLT

Certificate No : 570084626354



# ADDITIONAL REMARKS SCHEDULE

AGENCY Aon Risk Services Central, Inc.		NAMED INSURED Hyatt Corporation	
POLICY NUMBER See Certificate Number: 570084626354			
CARRIER See Certificate Number: 570084626354	NAIC CODE	EFFECTIVE DATE:	

**ADDITIONAL REMARKS**

THIS ADDITIONAL REMARKS FORM IS A SCHEDULE TO ACORD FORM,  
 FORM NUMBER: ACORD 25 FORM TITLE: Certificate of Liability Insurance

INSURER(S) AFFORDING COVERAGE	NAIC #
INSURER	
INSURER	
INSURER	
INSURER	

**ADDITIONAL POLICIES** If a policy below does not include limit information, refer to the corresponding policy on the ACORD certificate form for policy limits.

INSR LTR	TYPE OF INSURANCE	ADDL INSD	SUBR WVD	POLICY NUMBER	POLICY EFFECTIVE DATE (MM/DD/YYYY)	POLICY EXPIRATION DATE (MM/DD/YYYY)	LIMITS
	WORKERS COMPENSATION						
D		N/A		WC067940275 WA, WI	11/01/2020	11/01/2021	
C		N/A		WC017515930 NY	11/01/2020	11/01/2021	
	OTHER						
B				SP4063931 Excess WC - Florida SIR applies per policy terms & conditions	11/01/2020	11/01/2021	



# ADDITIONAL REMARKS SCHEDULE

AGENCY Aon Risk Services Central, Inc.		NAMED INSURED Hyatt Corporation	
POLICY NUMBER See Certificate Number: 570084626354			
CARRIER See Certificate Number: 570084626354	NAIC CODE	EFFECTIVE DATE:	

**ADDITIONAL REMARKS**

THIS ADDITIONAL REMARKS FORM IS A SCHEDULE TO ACORD FORM,  
 FORM NUMBER: ACORD 25 FORM TITLE: Certificate of Liability Insurance

workers Compensation Addendum

Policy Number: WC067940270  
 States Covered: CT, KS, MD, MN, MO, NC, NE, NJ, NM, OK, OR, TN, UT.

Policy Number: SP4063932  
 States Covered: AZ, CO, DC, GA, HI, IL, IN, KY, LA, MA, MI, NV, OH, PA, SC, TX, VA.



PRODUCT CODE

ESAF

PRODUCT NAME

EVENT SAFARI - OVERVIEW

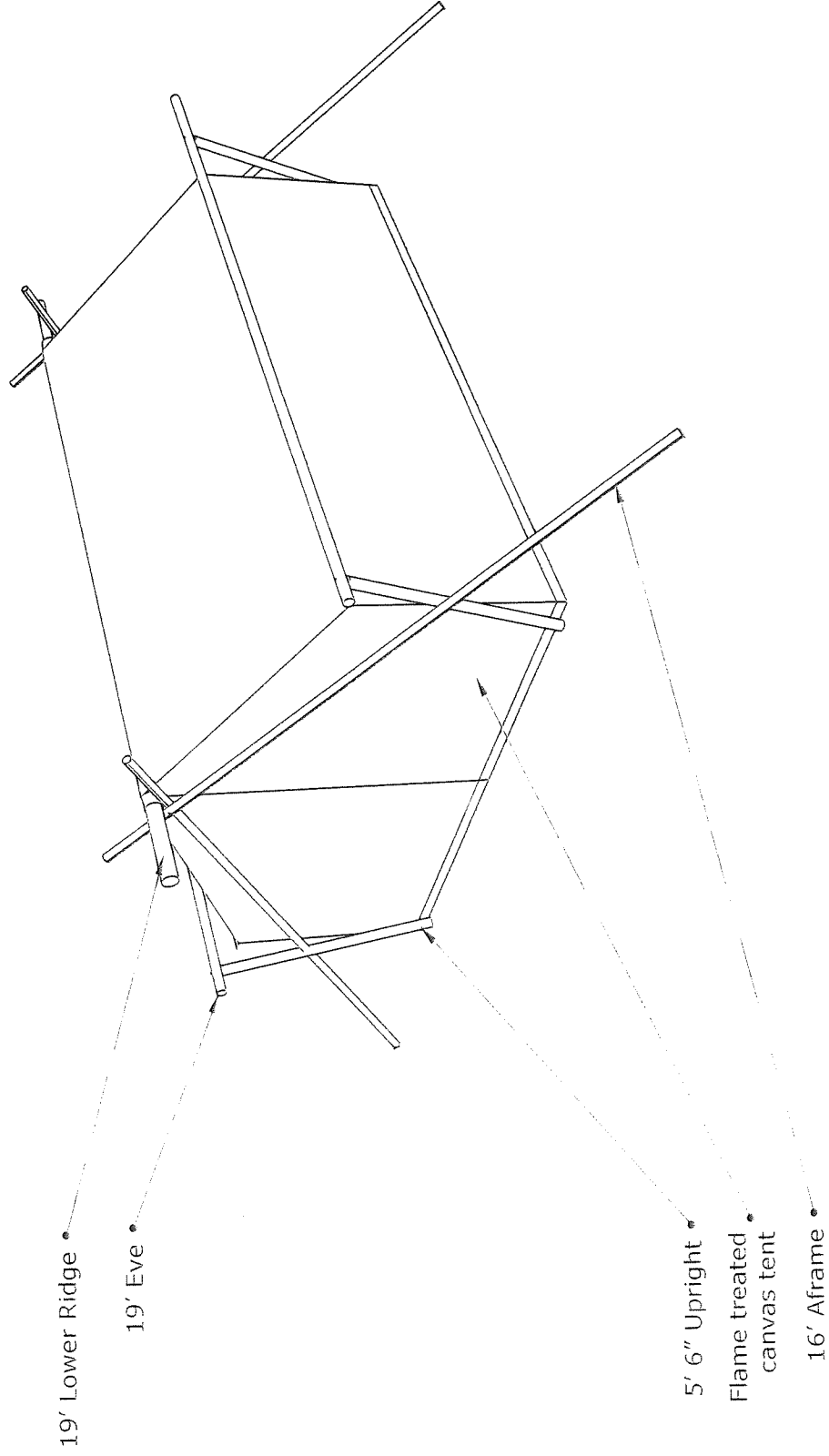





UNDER CANVAS

Under Canvas Inc.  
1172 Happy Lane  
Belgrade MT 59714

Phone - 1-800-257-0246  
Email: [events@undercanvas.com](mailto:events@undercanvas.com)

Ref # 5056

Date: April 2<sup>nd</sup>, 2021

This Order Form is subject to the Equipment Lease Agreement entered into by the Parties on 4/2/2021.

Event Name: EO Alchemy  
Client Name: Karen Nichols  
Client Phone: 775-355-1501  
Client Email: [karen@redcarpetdmc.com](mailto:karen@redcarpetdmc.com)  
Billing Contact: Michaelle Sherven- MichelleS@wetlaboratory.com  
Location/Site: Incline Village, Lake Tahoe, NV  
Rental Period: 10/11/2021-10/15/2021  
Set Up Start Date: 10/11/2021  
Event Start Date: 10/12/2021  
Event End Date: 10/14/2021  
Take Down Start Date: 10/14/2021  
Take Down Finish Date: 10/15/2021

QUANTITY	Item Type	Item Description	UNIT PRICE	TOTALS
2	MRQ Partial	Marqui - 30' diameter Includes Canvas Floor OR String Lights	\$4,000.00	\$8,000.00
1	SAF	Tent Set-up ONLY- 12'x16' footprint	\$1,000.00	\$1,000.00
8	Butterfly Chair		\$50.00	\$400.00
	Shipping			\$756.00
	Labor	Set Up and Take Down		\$9,495.60

**Payment Schedule:**

	<b>Subtotal</b>	\$19,651.60
	<b>Refundable Damage Deposit</b>	\$1,965.16
	<i>**Returned within 14 days of event conclusion pending product evaluation**</i>	
	<b>Estimated Applicable Taxes- 7.75%</b>	\$1,523.00
	<i>**Taxes may vary slightly based on event location**</i>	
	<b>Bronze Sponsorship- \$5K</b>	(\$5,000.00)
-1 Minute Video Spot (Under Canvas to provide video in preferred file format) -Logo on Website & Signage -Under Canvas Item included in Swag Bag (Under Canvas to provide quantity requested by EO Alchemy)		
	<b>50% Due Upon Contract Signature</b>	\$9,069.88
	<b>Remaining Balance due 30 days prior to Event Start Date 9/12/2021</b>	\$9,069.88

---

**Method of Payment: (Select One)**

- Credit Card
- Wire Transfer
- Check
- Other: \_\_\_\_\_

**Equipment Rental Agreement**

This Equipment Lease Agreement ("**Agreement**"), dated as of 4/2/2021 is by and between Under Canvas® Inc., a Delaware corporation, having its principal place of business at 1172 Happy Lane, Belgrade, MT 59714 ("**Under Canvas**"), and EO Alchemy ("**Client**," and together with Under Canvas, the "**Parties**," and each, a "**Party**").

WHEREAS, Under Canvas is in the business of leasing premier glamping tents, equipment, supplies and accessories; and

WHEREAS, Client desires to lease from Under Canvas, and Under Canvas desires to lease to Client, the equipment and supplies for Client's event(s) as more specifically described in this Agreement.

NOW, THEREFORE, in consideration of the mutual covenants, terms and conditions set forth herein, and for other good and valuable consideration, the receipt and sufficiency of which are hereby acknowledged, the Parties agree as follows:

**1. Definitions:**

1.1 "**Event**" means the event for which Client will use the Equipment, as set forth on the Order Form.

1.2 "**Order Form**" the rental order executed by the Parties for the Equipment.

1.3 "**Rental Charge**" is the amount payable by Client to Under Canvas for the lease, as set forth in the Order Form.

1.4 "**Rental Period**" is the period between completing the set-up of the Equipment and beginning the dismantling, as set forth in the Order Form.

1.5 "**Site**" shall mean the property for delivery of the Equipment, as set forth in the Order Form.

2. Lease. Under Canvas agrees to lease to Client, and Client agrees to lease from Under Canvas, the equipment described more fully in applicable Order Form (the "**Equipment**").

3. Operation of Equipment. Client shall not remove the Equipment from Client's address specified on the applicable Order Form without prior written approval of Under Canvas. Client shall allow Under Canvas to enter Client's premises at all reasonable times to locate and inspect

---

the state and condition of the Equipment. Client shall follow Under Canvas' instructions regarding the use and maintenance of the Equipment.

**4. Under Canvas Obligations:**

4.1 Under Canvas will use commercially reasonable efforts to deliver the agreed Equipment and Third Party Products on-time and in good working order as set forth in the Order Form. Under Canvas will set-up and take-down the Equipment as described in the Order Form.

4.2 Under Canvas will make every effort to complete the erection of the Equipment on or before the agreed date, provided that Client has complied with the undertakings set forth herein and in the applicable Order Form. If the Equipment is not erected because of delays due to weather or other circumstances beyond its reasonable control, Under Canvas shall not be liable to compensate Client.

4.3 Under Canvas will use commercially reasonable efforts to maintain and check the Equipment regularly during the applicable Rental Period. Under Canvas will take reasonable care to avoid damage to Clients' own equipment and property but cannot be responsible for any loss suffered by Client in respect thereof.

**5. Client Obligations:**

5.1 Upon execution of this Agreement, Client shall provide Under Canvas a detailed map or plan of the location, including the specific location(s) of any and all tents or other Equipment satisfying the requirements below.

5.2 Unless agreed otherwise in the applicable Order Form, the Rental Charge, outlined above, is based on the assumption that Client provides a firm, level, and sufficiently large location of grass (or some other material not impervious to stakes and able to absorb rainwater, as acceptable by Under Canvas in its sole discretion) on the Site, and it is served by a firm access road adjacent to the Site with adequate parking for commercial vehicles that is free from standing water, trees and overhead obstructions. If Client fails to comply with the foregoing or if Client wishes Under Canvas to erect the Equipment in a different position or location on the Site to the one indicated by Client to Under Canvas at the time of booking, and the costs to Under Canvas are subsequently increased, Under Canvas may increase the price of the Invoice accordingly.

5.3 Client shall inspect all Equipment before use and should notify Under Canvas of any miscounts, incorrect deliveries or unacceptable Equipment before use.

5.4 Client shall provide Under Canvas with either a plan showing the position in which the Equipment is to be erected and all underground services and any apparent obstacles, or to make available a representative on the Site for that purpose. In the absence of both, Under Canvas shall erect the Equipment where it thinks fit, which shall be deemed satisfactorily completed with respect to this Agreement, and Under Canvas shall not be responsible for damage to

---

underground services or any other damages caused by Client's failure to comply with this paragraph.

5.5 Client agrees not to light, or allow to be lit, any fire, candle or other naked flame other than use of the woodstoves within or close proximity to the Equipment without the prior written consent of Under Canvas.

5.6 Client shall not tamper with the structure or any part of the Equipment and, in particular, not to affix or suspend from the Equipment any item whatsoever without Under Canvas' prior written consent.

5.7 Client shall use the Equipment only for the stated and intended purposes and shall not allow any illegal or unlawful activity to occur on the Site at any time the Equipment is located thereon. Client shall assume and be solely responsible for all loss or damage to property, material, or equipment belonging to any Party that Client causes, and to any harm or damage incurred or suffered by any person on the Site. Client is encouraged to obtain all appropriate equipment, material, or other liability insurance(s) against such risk of loss.

5.8 Client shall inspect the Equipment upon completion of the set-up period as outlined above. Unless Client notifies Under Canvas in writing prior to the commencement of the Event, specifying any defect in or other proper objection to the Equipment, Client agrees that it shall be conclusively presumed that Client has fully inspected and acknowledged that the Equipment is in full compliance with the terms of this Agreement, is in good condition and repair, and that Client is satisfied with and has fully accepted the Equipment in such condition.

5.9 Client shall provide Under Canvas will full and complete access to the Equipment for the purposes of inspecting the Equipment and fulfilling Under Canvas' obligations hereunder.

5.10 Client shall not delay or hinder Under Canvas from completing set up or take-down in a timely manner. Should a delay be caused by Client that delays Under Canvas from completing its task, all additional expenses incurred will be charged directly to Client.

6. **Deposit and Damage Deposit.** A non-refundable 50% deposit ("**Deposit**") is required to confirm the Order Form payable upon the execution of the applicable Order Form, and the remainder of the applicable Invoice is payable 30 days prior to the first day of the Event. A separate refundable "**Damage Deposit**" is intended to cover Under Canvas against loss of or damage to all rented Equipment whatsoever the cause. The Damage Deposit will be returned to Client, less any damages to the tents and furnishings or Equipment, within 14 days after take-down has been completed. Please note charges incurred due to direct bank deposits will be deducted from the Damage Deposit.

7. **Rent.** In consideration of Client's right to possess and use the Equipment during the Term (as defined in Section 13), Client shall pay the Rental Charge in advance, 30 days prior to the Event, with set-off only for the Damage Deposit, in US dollars, by direct bank transfer (bank details: Rocky Mountain Bank, Under Canvas® Inc., Account Number 9100324230, Routing

---

Number 092901214) or by check (made payable to Under Canvas® Inc. at 1172 Happy Lane, Belgrade, MT 59714. Except with regards to the Damage Deposit, which may be returned to Client only as outlined herein, all such payment amounts shall immediately become non-refundable.

7.1 Under Canvas reserves the right not to provide the Equipment should full payment not be timely received as set forth herein. Client shall pay interest on all late payments at the lesser of the rate of 1.5% per month and the highest rate permissible under applicable law, calculated daily and compounded monthly. Client shall reimburse Under Canvas for all costs incurred in collecting any late payments, including, without limitation, attorneys' fees. Payment of any late charge does not excuse Client of any default under this Agreement.

7.2 All taxes, penalties, or fees due to any regulatory bodies will be charged as an addition to the Demand Deposit and Invoiced amounts, and are payable (in advance) by Client.

7.3 If by the termination or expiration of the Term, Client does not return the Equipment to Under Canvas in the condition and on the terms and conditions of Section 10, Client shall continue to comply with all the terms and conditions of this Agreement, including the obligation to pay two-hundred percent (200%) of the prorated daily Rental Charge for each day from the termination or expiration of the Term until the date on which Client returns such Equipment to Under Canvas in the manner required under Section 10 ("**Holdover Rent**"). It is imperative that Client return the Equipment as agreed and on-time. Client shall not construe anything contained in this Section, including Client's payment of Holdover Rent, as Under Canvas' (a) waiver of Client's failure to perform any obligation under this Agreement; or (b) assent to any renewal of this Agreement.

8. **Limited Warranty.** Under Canvas shall replace the Equipment with identical or similar Equipment if the Equipment fails to operate in accordance with the manufacturer's specifications and operation instructions. Such replacement shall be made as soon as practicable after Client returns, or alerts Under Canvas of, the non-conforming Equipment. Client shall return all non-conforming Equipment at its expense and risk of loss to Under Canvas to the destination specified by Under Canvas. Products manufactured by a third party ("**Third-Party Product**") may constitute, contain, be contained in, incorporated into, attached to, or packaged together with, the Equipment. Third-Party Products are not covered by the above limited warranty.

The limited warranty above does not apply where the Equipment has been subjected to abuse, misuse, neglect, negligence, accident, improper testing, improper installation, improper storage, improper handling, abnormal physical stress, abnormal environmental conditions, or use contrary to any instructions issued by Under Canvas, or used with any Third-Party Product, hardware, software, or product that has not been previously approved in writing by Under Canvas.

OTHER THAN AS SET FORTH ABOVE, UNDER CANVAS MAKES NO WARRANTY WHATSOEVER, INCLUDING ANY (a) WARRANTY OF MERCHANTABILITY; (b) WARRANTY OF FITNESS FOR A PARTICULAR PURPOSE; OR (c) WARRANTY AGAINST INTERFERENCE; OR (d) WARRANTY AGAINST

---

INFRINGEMENT OF ANY PATENT, COPYRIGHT, TRADEMARK, TRADE SECRET, OR OTHER PROPRIETARY RIGHTS OF A THIRD PARTY; WHETHER ARISING BY LAW, COURSE OF DEALING, COURSE OF PERFORMANCE, USAGE OF TRADE, OR OTHERWISE.

THE REMEDIES SET FORTH IN THIS SECTION 8 ARE CLIENT'S SOLE AND EXCLUSIVE REMEDIES AND UNDER CANVAS' ENTIRE LIABILITY FOR ANY BREACH OF THE LIMITED WARRANTY SET FORTH HEREIN.

9. Title and Risk of Loss. Title to the Equipment remains with Under Canvas throughout the Term, and Client shall acquire no right, title, or interest in the Equipment. Client shall not pledge or encumber the Equipment in any way. Client shall bear all risk of loss, damage, destruction, theft, and condemnation to or of the Equipment from any cause whatsoever ("**Loss**") until the Equipment has been returned to Under Canvas to the destination specified in Section. Client shall notify Under Canvas in writing within 5 days of any such Loss.

10. Return of Equipment.

10.1 Obligation to Return Equipment. Client shall, permit take-down, de-installation and removal of the Equipment as set forth in the Order Form.

10.2 Condition of Equipment upon Return. Client shall cause the Equipment returned for any reason under this Agreement to (a) be free and clear of all liens (other than liens of Under Canvas) and rights of third parties; (b) be in the same condition as when delivered to Client; and (c) be in compliance with applicable law. The Rental Charge does not include making good any repairs to the Site except to the extent caused by the negligence of Under Canvas' servants, agents or contractors.

10.3 Compliance with Law. Client shall (a) comply with all applicable laws, regulations, and ordinances and (b) maintain in effect all the licenses, permissions, authorizations, consents, and permits that it needs to carry out its obligations under this Agreement. Additionally, Client shall obtain any and all permits of any kind or nature from any authorities, and to make application where necessary to all: planning and border authorities, zoning laws or commissions; brokers; blue stakes or other similar organizations for any and all underground systems or structures; district surveyor or similar agencies; police, fire, or other emergency response agency; forest service, any and all other similar authority or organization as required for the Event, the site and Equipment-related services described herein (the "**Licenses**"). Any costs incurred in delays or modifications in the work arising from the absence or misrepresentation of all Licenses shall be payable to Under Canvas by Client. Client shall obtain and completely and fully satisfy all requirements under the Licenses and notify Under Canvas of all such obligations or requirements with which it must comply, in writing, at least 28 days prior to set-up. Should Under Canvas for any reason be unable to comply with these requirements, then it shall notify Client and the Agreement and/or applicable Order Form(s) shall be deemed to have been cancelled by Client.

11. Indemnification. Client shall indemnify, defend, and hold harmless Under Canvas and its officers, directors, employees, agents, affiliates, successors, and permitted assigns

---

(collectively, “**Indemnified Party**”) against any and all losses, damages, liabilities, deficiencies, claims, actions, judgments, settlements, interest, awards, penalties, fines, costs, or, expenses of whatever kind, including attorneys’ fees, fees and the costs of enforcing any right to indemnification under this Agreement, and the cost of pursuing any insurance providers, incurred by Indemnified Party, relating to any claim of a third party arising out of or occurring in connection with the Equipment or Client’s negligence, willful misconduct, death, bodily injury, property damage, or breach of this Agreement, except to the extent due to gross negligence by Under Canvas. Client shall not enter into any settlement without Under Canvas’ or Indemnified Party’s prior written consent.

12. Insurance. Under Canvas strongly recommends that Clients obtain insurance for its possible damage to the Equipment.

13. Term and Termination. The term of this Agreement commences on the date of this Agreement and continues until terminated as provided under this Agreement (the “**Term**”). In addition to any remedies that may be provided in this Agreement, either Party may terminate this Agreement and/or the applicable Order Form(s) with immediate effect upon notice to the other Party, if the other Party: (i) fails to pay any amount when due under this Agreement or the applicable Order Form(s) and such failure continues for 30 days after the other Party’s receipt of notice of nonpayment; (ii) has not otherwise performed or complied with any of the terms of this Agreement, in whole or in part; or (iii) becomes insolvent, files a petition for bankruptcy, or commences or has commenced against it proceedings relating to bankruptcy, receivership, reorganization, or assignment for the benefit of creditors. If Client is in default of any of the terms and conditions of this Agreement, Under Canvas, and its agents, at Client’s risk, cost, and expense may at any time enter Client’s premises where the Equipment is stored or used and recover the Equipment. Either Party may cancel this Agreement and/or any Order Form(s) upon 30 days’ written notice to the other Party. Client acknowledges that if Client cancels the Agreement or the applicable Order Form at any time prior to 30 days before the start of the set-up of the Event, then the Deposit shall be non-refundable and shall be retained by Under Canvas. If Client terminates the Agreement and/or any Order Form(s) at any time following 30 days before the start of the set-up of the Event, then the entire Invoice and Rental Charges for the applicable Order Form(s) shall be non-refundable. Any and all unpaid amounts otherwise due and owing shall continue to be due and owing by Client upon termination of this Agreement and/or any Order Form(s).9/10

14. Confidential Information. All non-public, confidential, or proprietary information of Under Canvas, including, but not limited to, specifications, samples, patterns, designs, plans, drawings, documents, data, business operations, customer lists, pricing, discounts, or rebates, disclosed by Under Canvas to Client, whether disclosed orally or disclosed or accessed in written, electronic, or other form or media, and whether or not marked, designated, or otherwise identified as “confidential,” in connection with this Agreement is confidential, solely for the use of performing this Agreement and may not be disclosed or copied unless authorized by Under Canvas in writing. Upon Under Canvas’ request, Client shall promptly return all documents and other materials received from Under Canvas. Under Canvas shall be entitled to injunctive relief

---

for any violation of this Section. This Section shall not apply to information that is: (a) in the public domain; (b) known to Client at the time of disclosure; or (c) rightfully obtained by Client on a non-confidential basis from a third party.

15. Entire Agreement. This Agreement, including and together with any related exhibits, schedules, attachments, Order Forms, and appendices, constitutes the sole and entire agreement of the Parties with respect to the subject matter contained herein, and supersedes all prior and contemporaneous understandings, agreements, representations, and warranties, both written and oral, regarding such subject matter.

16. Survival. Subject to the limitations and other provisions of this Agreement: (a) the representations and warranties of the Parties contained herein shall survive the termination of this Agreement; and (b) Sections 1, 5, 7 and 10 through 29 of this Agreement, as well as any other provision that, in order to give proper effect to its intent, should survive such expiration or termination, shall survive the expiration or earlier termination of this Agreement.

17. Notices. All notices, requests, consents, claims, demands, waivers, summons, and other legal process, and other similar types of communications hereunder must be in writing and addressed to the relevant Party at the address set forth on the first page of this Agreement (or to such other address that may be designated by the receiving Party from time to time in accordance with this Section 17), or via return-receipt email to [Hannah.brennan@undercanvas.com](mailto:Hannah.brennan@undercanvas.com). All non-emailed notices must be delivered by personal delivery, nationally recognized overnight courier (with all fees pre-paid), or certified or registered mail (in each case, return receipt requested, postage prepaid). A notice is effective only (i) upon receipt by the receiving Party, or in the case of email, upon the time/date of the automated return receipt email, and (ii) if the Party giving the notice has complied with the requirements of this Section 17.

18. Severability. If any term or provision of this Agreement is invalid, illegal, or unenforceable in any jurisdiction, such invalidity, illegality, or unenforceability shall not affect any other term or provision of this Agreement or invalidate or render unenforceable such term or provision in any other jurisdiction.

19. Amendments. No amendment to or modification of this Agreement is effective unless it is in writing and signed by each Party.

20. Waiver. No waiver by any Party of any of the provisions of this Agreement shall be effective unless explicitly set forth in writing and signed by the Party so waiving. Except as otherwise set forth in this Agreement, no failure to exercise, or delay in exercising, any rights, remedy, power, or privilege arising from this Agreement shall operate or be construed as a waiver thereof, nor shall any single or partial exercise of any right, remedy, power, or privilege hereunder preclude any other or further exercise thereof or the exercise of any other right, remedy, power, or privilege.



---

21. Cumulative Remedies. All rights and remedies provided in this Agreement are cumulative and not exclusive, and the exercise by either Party of any right or remedy does not preclude the exercise of any other rights or remedies that may now or subsequently be available at law, in equity, by statute, in any other agreement between the Parties, or otherwise. Notwithstanding the previous sentence, the Parties intend that Client's rights under Section 8 are Client's exclusive remedies for the events specified therein.

22. Assignment; Successors and Assigns. Client shall not assign, transfer, delegate, or subcontract any of its rights or obligations under this Agreement without the prior written consent of Under Canvas. Any purported assignment or delegation in violation of this Section shall be null and void. No assignment or delegation shall relieve Client of any of its obligations hereunder. Under Canvas may at any time assign, transfer, or subcontract any or all of its rights or obligations under this Agreement without Client's prior written consent. This Agreement is binding on and inures to the benefit of the Parties to this Agreement and their respective permitted successors and permitted assigns.

23. No Third-Party Beneficiaries. This Agreement benefits solely the Parties to this Agreement and their respective permitted successors and assigns and nothing in this Agreement, express or implied, confers on any other Person any legal or equitable right, benefit or remedy of any nature whatsoever under or by reason of this Agreement.

24. Choice of Law and Choice of Forum. This Agreement and all matters arising out of or relating to this Agreement are governed by, and construed in accordance with, the laws of the State of Delaware, without regard to the conflict of laws provisions of such State. Subject to Article 25, any legal suit, action, or proceeding arising out of or relating to this Agreement must be instituted in the federal courts of the United States of America or the courts of the State of Colorado, and each Party irrevocably submits to the exclusive jurisdiction of such courts in any such suit, action, or proceeding. The parties expressly agree that the United Nations Convention on Contracts for the International Sale of Goods shall not apply to this Agreement.

25. Arbitration. Any and all claims, controversies and disputes between the parties hereto that arise out of or relate to this Agreement, or to the breach, termination or invalidity thereof, shall be exclusively and finally settled by arbitration before the American Arbitration Association and in accordance with the Commercial Arbitration Rules of the American Arbitration Association. There shall be one arbitrator who shall be appointed by the American Arbitration Association. The location of the arbitration shall be Denver, Colorado, unless otherwise agreed by the parties hereto in writing. The arbitrator shall be solely bound and governed by the laws of the State of Delaware, without regard to the choice or conflicts of laws rules thereof and without regard to the United Nations Convention on Contracts for the International Sale of Goods. The arbitrator shall take into account every dispute or difference arising between the parties hereto and shall provide the parties hereto with written reasons for the arbitration award. The arbitrator shall have no authority to make any decision or issue any award that is inconsistent with this Agreement and, in addition, shall have no power to award indirect, incidental, consequential, special or punitive damages. Any arbitration award shall be stated and paid in

---

U.S. Dollars and shall specify the arbitration costs to be borne by each party, including attorneys' fees. The arbitration award shall be final and binding on all parties. Judgment upon the award may be entered in any court of record having competent jurisdiction.

26. Limitation of Liability. IN NO EVENT SHALL UNDER CANVAS BE RESPONSIBLE OR LIABLE FOR ANY CONSEQUENTIAL, INDIRECT, INCIDENTAL, SPECIAL, EXEMPLARY, PUNITIVE, OR ENHANCED DAMAGES, LOST PROFITS OR REVENUES, OR DIMINUTION IN VALUE, ARISING OUT OF OR RELATING TO ANY BREACH OF ANY PROVISION OF THIS AGREEMENT, REGARDLESS OF (A) WHETHER SUCH DAMAGES WERE FORESEEABLE, (B) WHETHER OR NOT UNDER CANVAS WAS ADVISED OF THE POSSIBILITY OF SUCH DAMAGES, AND (C) THE LEGAL OR EQUITABLE THEORY (CONTRACT, TORT, OR OTHERWISE) UPON WHICH THE CLAIM IS BASED, AND NOTWITHSTANDING THE FAILURE OF ANY AGREED OR OTHER REMEDY OF ITS ESSENTIAL PURPOSE. IN NO EVENT SHALL UNDER CANVAS' AGGREGATE LIABILITY UNDER THIS AGREEMENT EXCEED THE TOTAL OF THE AMOUNTS PAID TO UNDER CANVAS. EXCEPT AS SET FORTH HEREIN, UNDER CANVAS MAKES NO WARRANTIES, EXPRESS OR IMPLIED, AS TO ANY MATTER WHATSOEVER, INCLUDING, WITHOUT LIMITATION, THE CONDITION OF THE EQUIPMENT, ITS MERCHANTABILITY, ITS DESIGN, ITS CAPACITY, ITS PERFORMANCE, ITS MATERIAL, ITS WORKMANSHIP, ITS FITNESS FOR ANY PARTICULAR PURPOSE, OR THAT IT WILL MEET THE REQUIREMENTS OF ANY LAWS, RULES, SPECIFICATIONS. UNDER CANVAS FURTHER DISCLAIMS ANY LIABILITY WHATSOEVER FOR LOSS, DAMAGE, OR INJURY TO CLIENT OR THIRD PARTIES AS A RESULT OF ANY DEFECTS IN, INEFFICIENCY OF, OR BREAKAGE OF THE EQUIPMENT. AS TO UNDER CANVAS, CLIENT LEASES THE EQUIPMENT "AS IS".

27. Force Majeure. Under Canvas shall not be liable or responsible to Client, nor be deemed to have defaulted or breached this Agreement, for any failure or delay in fulfilling or performing any term of this Agreement when and to the extent such failure or delay is caused by or results from acts or circumstances beyond the reasonable control of Under Canvas including, without limitation, acts of God, flood, fire, earthquake, car accidents, border control, explosion, governmental actions, war, invasion or hostilities (whether war is declared or not), terrorist threats or acts, riot, or other civil unrest, national emergency, revolution, insurrection, epidemic, lockouts, strikes or other labor disputes (whether or not relating to either Party's workforce), or restraints or delays affecting carriers or inability or delay in obtaining supplies of adequate or suitable materials, materials or telecommunication breakdown, or power outage.

28. Counterparts. This Agreement may be executed in counterparts, each of which is deemed an original, but all of which together are deemed to be one and the same agreement.

29. Headings. Headings in this Agreement are for convenience of reference only, and are not to be used in any interpretation of the agreement between the Parties.

---

**ACCEPTANCE**

When presented by Under Canvas®, Inc to EO Alchemy this document is an invitation to make an offer. Upon signature by Client, this document will be an accepted offer. Only upon signature of this document by all parties and the requested deposit, will this document constitute a binding agreement. Unless Under Canvas®, Inc otherwise notifies Client at any time prior to Client's execution of this document, the order form and dates will be held by Under Canvas®, Inc for Client on a first-option basis until 4/16/2021. If Client cannot make a commitment prior to or by that date, this invitation to offer will revert to a second-option basis or, at Under Canvas®, Inc discretion, will be released into general sale, in which case neither party will have any further obligations or liabilities.

Upon signature by both parties, EO Alchemy and Under Canvas®, Inc shall have agreed to and executed this Agreement by their authorized representatives as of the dates indicated below.

EO Alchemy

Signature:

Name: Kyle McClelland

Title: Event Co-Chair

Date:

Under Canvas®, Inc.

Signature:

Name: Hannah Brennan

Title: Director of Events

Date:

# SITE EVACUATION PLAN

Safari Tent is a 12'x16' on a 32'x24' stage

Grass / Garden Area

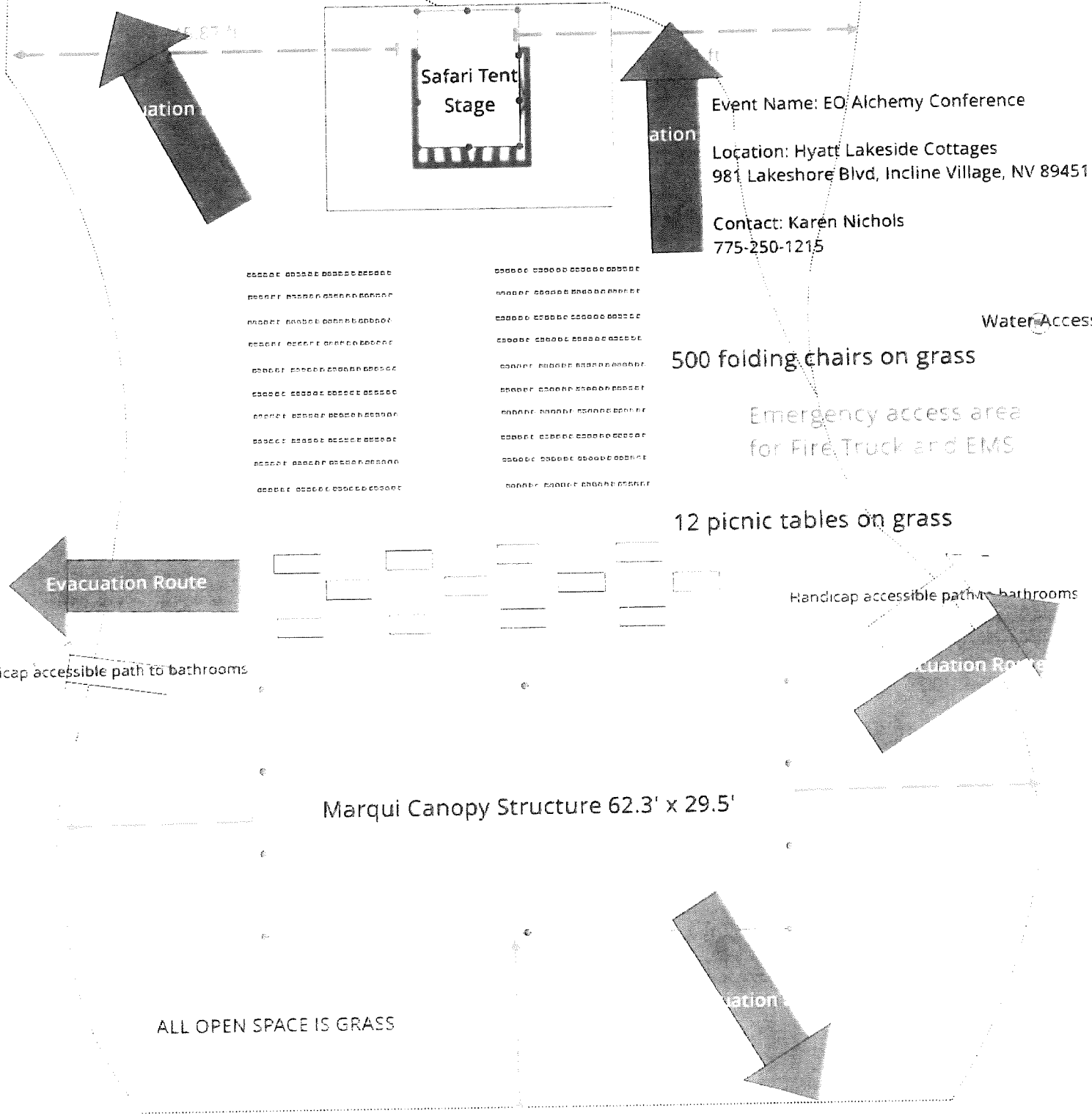

500 folding chairs on grass

Emergency access area for Fire Truck and EMS

12 picnic tables on grass

Marqui Canopy Structure 62.3' x 29.5'







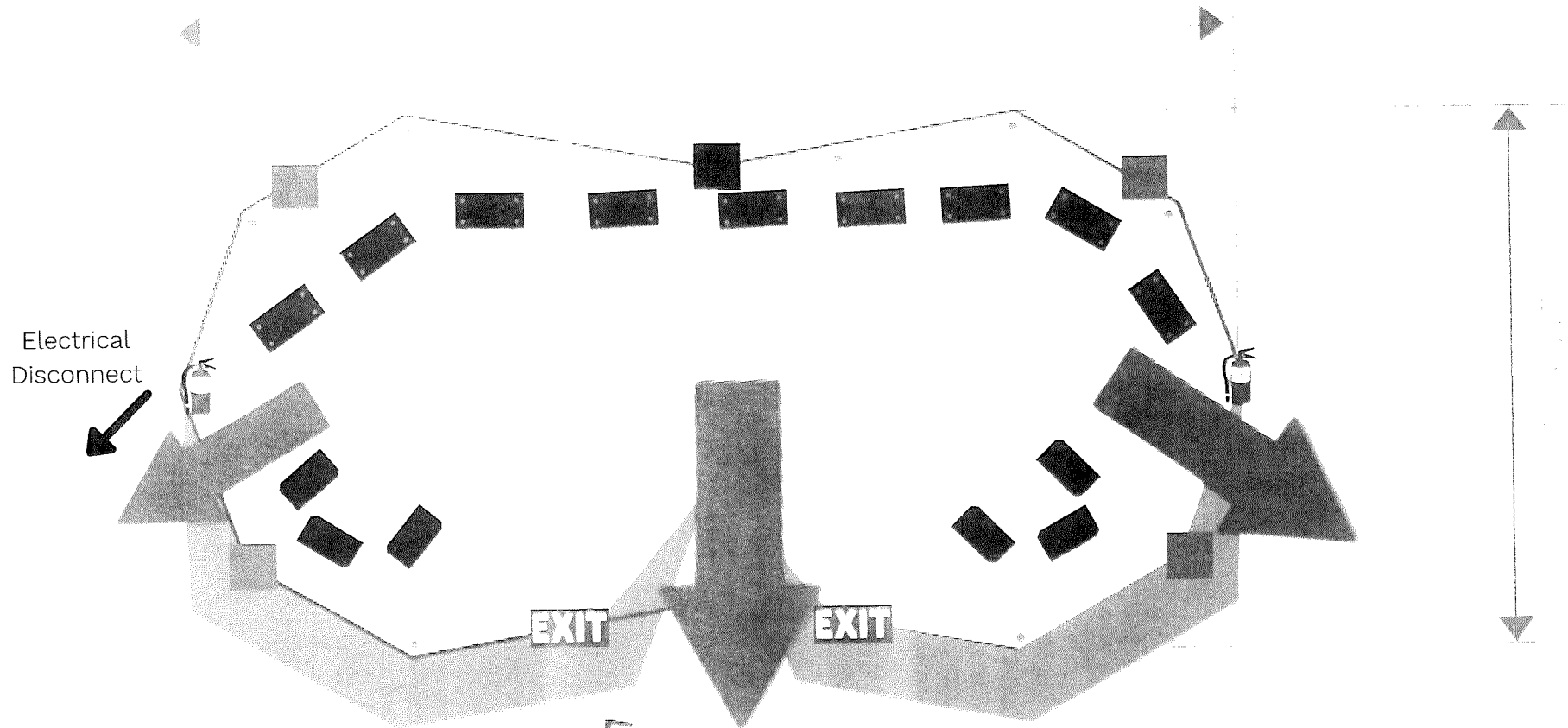

ALL OPEN SPACE IS GRASS

5ft pathway surrounding grass (pathway starting at the dotted lines)

# ATTACHMENT D

# Marqui Tent Evacuation Plan



-  Sides Raised / Egress / Exit
  -  Sides Lowered
  -  Booth - 20" deep x 55" wide (all booths will be 3ft from all sides of tent) - quantity 9
  -  Couch groupings - 6ft long couches - quantity 6
  -  Fire extinguisher quantity 2
  -  occupant load sign
  -  no smoking signs
  -  Illuminated Exit signs will be hung - quantity 2
-  EXIT PLAN

# Safari Tent Evacuation Plan

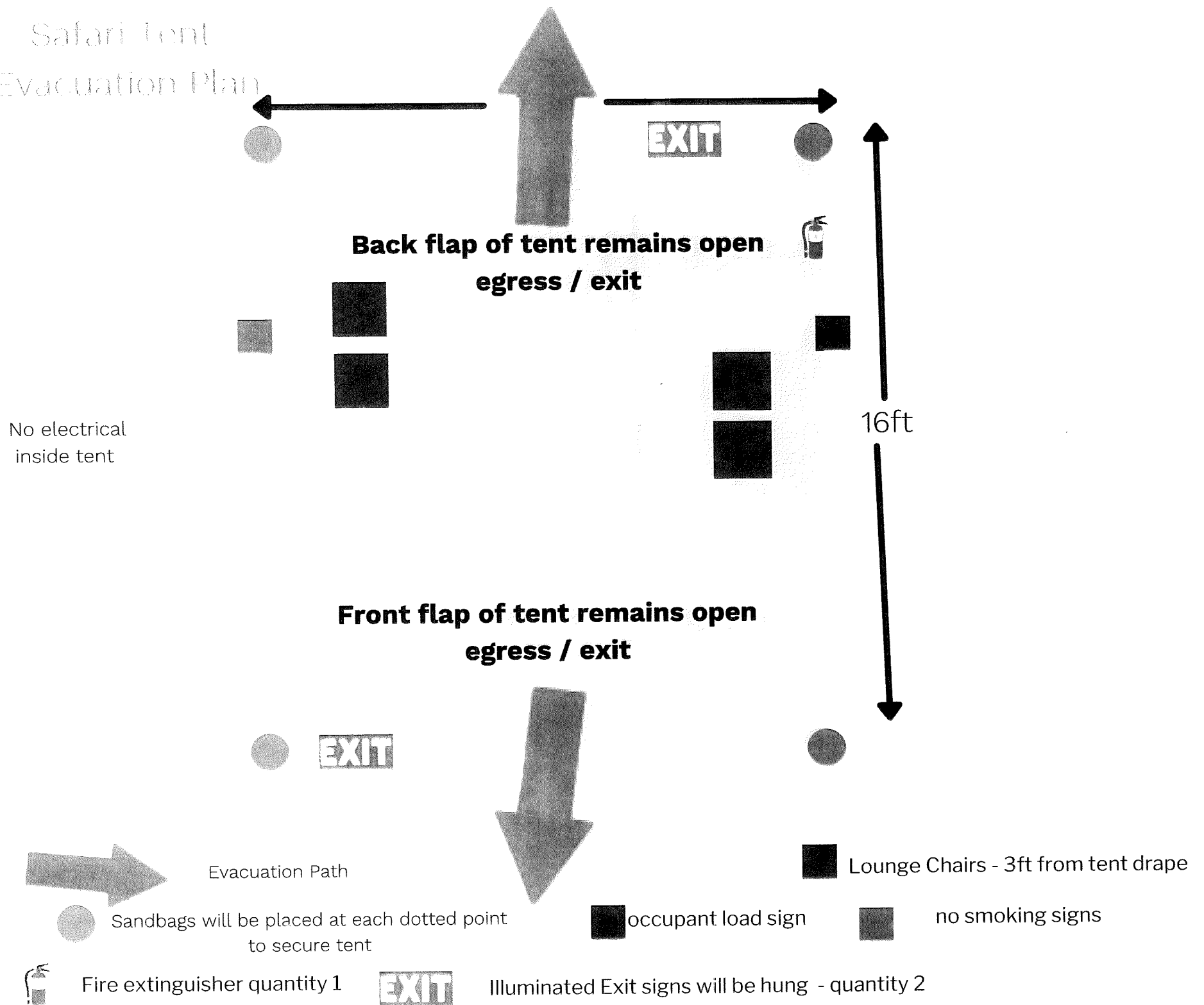

**Back flap of tent remains open  
egress / exit**

**Front flap of tent remains open  
egress / exit**

16ft

No electrical  
inside tent

Evacuation Path

Sandbags will be placed at each dotted point  
to secure tent

Fire extinguisher quantity 1

occupant load sign

Lounge Chairs - 3ft from tent drape

no smoking signs

Illuminated Exit signs will be hung - quantity 2

## Project Description

Event Name: The Entrepreneur's Organization 2021 Alchemy Conference

Event Address: Hyatt Regency Lake Tahoe Resort, Spa and Casino, 981-993 Lakeshore Blvd, Incline Village, NV 89451

Contacts: Karen Nichols, [karen@redcarpetdmc.com](mailto:karen@redcarpetdmc.com), office (775) 355-1501, cell (775) 250-1215

Event Dates: October 12-14, 2021 (set 10/11/21, strike 10/15/21)

Project Description: This year's countrywide conference, Alchemy, for The Entrepreneur's Organization is being held at the Hyatt Regency Hotel in Incline Village, Nevada. The event runs from October 11-14, 2021, and will host 400 entrepreneurs and their guests, for a total of around 500 people.

We seek permits to put up two tents for the duration of this conference. Both will go up on Monday, October 11, 2021, and come down on Friday, October 15, 2021. They are owned by and will be set up and properly secured (using sandbags and no guy lines) by Under Canvas on the Cottage Green in the Lakeside area at the Hyatt.

The smaller tent, the Safari Tent, is 12' x 16'. It will be set up on a 24' x 32' stage and serve as a sort of "green room" for speakers prepping to go out on stage and address conference attendees. It will hold a few chairs for queued presenters and a handful of personal effects while presenters are out on stage. It will not have electricity, gas, or anything else of that nature and both ends will remain propped open for the duration of the conference. It will be securely planted using the sandbags of the appropriate calculated weight, determined by Under Canvas.

The larger tent, the Marqui Tent, is 62' x 29'. It will be set on grass and hold 9 sponsor booths (each of which are 4.5' x 2') and two clusters of three couches each. It will have electricity provided by the Hyatt, set up by the AV team. The entire long side facing the rest of the Cottage Green will be set open for the duration of the event. It will be securely planted using sandbags of the appropriate weight, as calculated by Under Canvas.

Access to restrooms and port-o-potties can be found on each side of the Cottage Green. Emergency vehicle access is easily reached just behind both sides of the ring of cottages surrounding the Green. A large water valve is also located on the North side of the Cottage Green. Adequate signage ("Exit", "No Smoking", and "Occupant Load" for each tent) as well as fire extinguishers will be prominently posted.

In between the Marqui Tent and the stage containing the Safari Tent will be 500 folding chairs set in the grass and 12 picnic tables. Tents will not be occupied (except by set up and strike crews) on Monday, October 11 and Friday, October 15, but will have conference attendees engaged in outdoor general sessions on Tuesday through Thursday, October 12-14, 2021.

ATTACHMENT E



# Hotel Security and Event Planning Guide

## Hotel Contact Information

Hotel Name:	Hyatt Regency Lake Tahoe Resort, Spa & Casino	General Manager:	Michael Murphy
Hotel Street Address:	111 Country Club Drive	Telephone Number:	(775) 886-6755
Hotel City / Country:	Incline, Village, NV, USA	Director of OPS:	Tyler Stirrett / Andrew DeLapp
Hotel Main Tele #:	(775) 832-1234	Telephone Number:	(775) 886-6743
Hotel Fax Number:	(775) 831-2171	Security Manager:	Scott MacFarlane
Hotel E-mail Address:	www.laketahoe.hyatt.com	Telephone Number:	(775) 886-6710

## Property Description Information

Located in North Lake Tahoe, the resort features 422 rooms and cottages, a 20,000 square foot spa, 24-hour casino, four restaurants, including Long Eagle Grille, 24-hour Stayfit fitness center, year-round heated pool, two hot tubs, three outdoor fire pits, 66,200 square feet of meeting space, private beach and Camp Hyatt.

## Facility Attributes

Total number of floors in main building: 9  
 Total number of guest rooms for property: 422  
 Number of floors above ground: 9  
 Number of floors below ground: 0  
 Number of stairways for use in an emergency in main building: 2  
 Hotel has an emergency generator to support basic infrastructure (lighting, lifts, etc.)  YES  NO

### Local Contact Information:

Authority Name:	Washoe County Sheriff's Department	Authority Name:	North Lake Tahoe Fire Protection District
Authority Address:	625 Mount Rose Hwy. Incline Village, NV (775) 832-4107 In the event of an Emergency, contact #911	Authority Address:	886 Oriole Way, Incline Village, NV (775) 831-0351 In the event of an Emergency, contact #911
Approximate Distance to Hotel and Travel Time:	3.7 miles, 8 minutes	Approximate Distance to Hotel and Travel Time:	1.5 miles, 5 minutes

ATTACHMENT F





**HYATT**  
REGENCY  
LAKE TAHOE  
RESORT SPA & CASINO

### Ambulance Service

Service Name: North Lake Tahoe Fire Protection District  
 Service Address: 886 Oriole Way, Incline Village, NV  
 Service Tele #: (775) 831-0351  
 In the event of an Emergency, contact #911  
 Approximate Distance to Hotel and Travel Time: 1.5 miles, 5 minutes

### Hospital

Name: Incline Village Community Hospital  
 Address: 880 Alder Ave. Incline Village, NV  
 Telephone #: (775) 883-4100  
 In the event of an Emergency, contact #911  
 Approximate Distance From Hotel and Travel Time: 1.2 miles, 4 minutes

## Fire, Life Safety, and Security Considerations

### Fire Systems

The hotel has a fire emergency plan (which includes evacuation assembly areas) that may be reviewed at the office of the General Manager.

Heat detectors are located in:

- Boiler Room
- Kitchen areas
- Laundry area (has sprinklers)

The Hotel has Smoke Detectors:

- In Guest Rooms
- In Public Areas

The Hotel has Sprinklers:

- In Guest Rooms
- In Public Areas
- The fire alarm system has a PA (public address) functionality to enable emergency announcements.
- Emergency lighting and fire extinguishers comply with local fire code and are regularly inspected.

Corridors have no dead end more than 10 meters from evacuation stairway. (A dead end is an area where escape in an emergency is only possible in one direction).

Maintenance/Inspection records for fire system and fire equipment are available for review at the office of the hotel General Manager.

Corridors and stairways are fitted with emergency lighting units.

Public Areas, corridors and stairways contain signs indicating evacuation routes.

Exit doors are unobstructed and final Exit doors are unobstructed externally.

Emergency stairways have self-closing fire resistant doors.

Emergency stairways are fitted with handrails and kept clear of obstructions.

Emergency stairways discharge to outside of building (open air).

Emergency exit doors are fitted with locks that enable immediate release and opening.

Emergency exit doors are fitted with locks that enable immediate release and opening.

The Hotel has systems and procedures to enunciate an alarm in the case of a fire or other emergency.

The Hotel fire alarm system is tested on a regular basis.

The Hotel has fire extinguishers on guest floors, in public areas, and in key BOH areas.



### Health and Life Safety

- The Hotel has a food safety management system based on HACCP principles.
- The Hotel conducts regular hygiene inspections.
- Upon request, a private licensed Physician or medical care provider can be summoned to the hotel.
- The Hotel has procedures to mitigate Legionella.
- The Hotel has pest control measures in place which cover Food Control areas, public areas, and guest room areas.

### Guest Room Security

Guest Rooms have:

- Deadbolt Locks
- Door Chain or Wishbone Latch
- Door Closure Mechanism
- View Ports with Privacy Flap
- Guest Rooms with balconies have internal locking devices to deter forced entry.
- The guest room balcony façade has no gap greater than 100mm.
- Guest Room connecting room doors have a deadbolt lock.
- Guest Rooms are fitted with a convenience safe.
- Guest Room appliances have instructions for use in English.
- Guest Room has a compendium which contains guidance for guests to follow in case of Fire and other emergencies.
- Guest rooms have Safety Exit maps on back of door.
- The height of guest room balcony surround is greater than 1.0 meter.
- Guest rooms have no gas-operated appliances or water heater.

### Hotel Elevators/Lifts

Hotel elevators have following notices displayed outside the lift on each floor:

- DO NOT USE IN CASE OF FIRE
- NO SMOKING (in the lift)
- NO UNACCOMPANIED CHILDREN

- Hotel elevators/lifts have an emergency alarm and communication system.

The number of elevators/lifts is: 9

(operating certificates are available and may be reviewed at the office of the hotel General Manager)

### Security Systems and Equipment

- The hotel has emergency response protocols and procedures for natural disasters and other security contingencies, and for safety-related incidents that may be reviewed at the office of the General Manager.
- The Hotel has on-site security staff 24 hours per day.
- The Hotel has a process for increasing security manpower for meetings or events upon request.
- Pool water is checked as per local regulations for ph and chlorine.
- Pool has clearly designated depth markings visible from within the pool and around it.



**HYATT**  
**REGENCY**  
COURT YARDS  
 BEVERLY HILLS, CALIFORNIA

- |  |  |
|--|--|
| <ul style="list-style-type: none"> <li><input checked="" type="checkbox"/> The Hotel has a Security Awareness training program for Associates.</li> <li><input checked="" type="checkbox"/> The Hotel utilizes CCTV surveillance systems.</li> <li><input checked="" type="checkbox"/> All Hotel staff receives training in actions to be taken in the event of a Fire and other emergencies, and key staff receives First Aid and CPR training.</li> <li><input checked="" type="checkbox"/> An internal emergency telephone number is available and continually staffed.</li> <li><input checked="" type="checkbox"/> The Hotel is able to secure Function Rooms to provide "client-only" access.</li> <li><input checked="" type="checkbox"/> The Hotel car parks have entry and exit controls.</li> <li><input checked="" type="checkbox"/> The Hotel conducts periodic Security &amp; Safety inspections.</li> <li><input checked="" type="checkbox"/> The Hotel is a member of the Overseas Security Advisory Council (OSAC).</li> </ul> | <ul style="list-style-type: none"> <li><input checked="" type="checkbox"/> Buoyancy aids are provided at the pool side.</li> <li><input checked="" type="checkbox"/> Pool surround area has non-slip surface.</li> <li><input checked="" type="checkbox"/> Pool has general "pool regulations" notice board and signage that advises whether or not there is a lifeguard on duty during operating hours.</li> <li><input checked="" type="checkbox"/> Fitness Center has controlled access and alarm system to summon emergency assistance.</li> </ul> |
|--|--|

### Nightclubs and Conference Rooms

- Hotel has discotheque or nightclub on premises
- Hotel has separate access controls/procedures for the discotheque/nightclub.
- Conference rooms are fitted with A/V capabilities & have support staff available to provide assistance.

## Reporting Security or Safety Incidents

The security and safety of our guests and associates is of utmost importance to us. If a health, safety, or security situation arises which should be brought to our attention, we ask that you observe the following reporting protocol:

If the situation is an emergency --- dial 55 from any hotel phone and immediately report it. If the matter is NOT an emergency, dial 0 from any hotel phone, ask to speak to the Security Manager on Duty, and report the matter accordingly.

As you can appreciate, to avoid compromising Hotel security and safety systems, there are limits on what the Hotel may disclose (such as information concerning security camera or alarm system plans) or routinely provide upon demand (such as copies of security plans or procedures, staffing information, training information, etc.).

These limitations are in the interest of protecting guests and associates. We recognize, however, that you may wish to further discuss security or safety matters.

If so, you are welcome to contact the Hotel General Manager.

# STRUCTURAL CALCULATIONS PACKAGE

Customer : Under Canvas, Inc.  
Project No : UC19009  
Project Name : Event Tent  
Location : Palm Springs, CA  
Application : Tensile Membrane Structures  
Model : MarquiCanopy



*Greg Riley*

Prepared By



Yuri Yurianto, S.E. P.E. M.Sc.  
5760 Legacy Dr Ste B3-333. Plano, TX 75024  
(972) 896-7373  
yurianto@modularconsultant.com  
MSC Project No UC19009  
Date: 12/30/2019  
Rev: Final

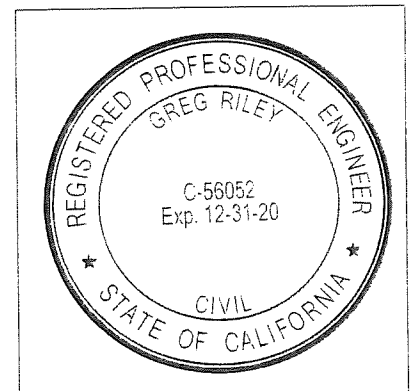

ATTACHMENT 9

Company:	Modular Structural Consultants, LLC	Project Number:	UC19009	MSC# UC19009
Engineer:	Yuri Yurianto, S.E., P.E., M.Sc.	Project Name:	Event Tent	
Address:	5760 Legacy Dr, Ste. B3-333. Plano, TX 75024	Location:	Palm Springs, CA	
Phone:	(972) 896-7373	Model:	MarquiCanopy	
Email:	yurianto@modularconsultant.com	Date:	12/30/2019	Final

TABLE OF CONTENT

Cover

Table of Content

Site Specific Climatic Info

Design Criteria

Design Loads Calculations

    Live

    Wind

Finite Element Analysis (FEA)

    Geometry

    Timber AWC Check

    Support Reactions

Anchor Tie-Down Design

Company: Modular Structural Consultants, LLC  
 Engineer: Yuri Yurianto, S.E., P.E., M.Sc.  
 Address: 5760 Legacy Dr, Ste. B3-333, Plano, TX 75024  
 Phone: (972) 896-7373  
 Email: yurianto@modularconsultant.com

Project Number: UC19009 MSC# UC19009  
 Project Name: Event Tent  
 Location: Palm Springs, CA  
 Model: MarquiCanopy  
 Date: 12/30/2019 Final

ATC HAZARDS BY LOCATION

<https://hazards.atcouncil.org/>

Address: Palm Springs, CA

Design load code ASCE 7-16  
 Risk Category I

Wind Speed 75 mph

Ground Elevation 479 ft from sea level  
 Wind Exposure Category B

ATC Hazards by Location

Our Sponsors About ATC Contact API

Seismic  $S_s = 1.774$  g  
 $S_1 = 0.846$  g

Ground Snow  $p_g = 0.00$  psf  
 Non Reducible Roof Snow n/a

Symbol	Value	Description
$S_s$	1.774	MCE <sub>s</sub> ground motion (period=0.2s)
$S_1$	0.846	MCE <sub>1</sub> ground motion (period=1.0s)
$S_{MS}$	1.774	Site-modified spectral acceleration value
$S_{M1}$	1.268	Site-modified spectral acceleration value
$S_{DS}$	1.193	Numeric seismic design value at 0.2s SA
$S_{D1}$	0.846	Numeric seismic design value at 1.0s SA

ASCE 7-16  
 Ground Snow Load C

Company:	Modular Structural Consultants, LLC	Project Number:	UC19009	MSC# UC19009
Engineer:	Yuri Yurianto, S.E., P.E., M.Sc.	Project Name:	Event Tent	
Address:	5760 Legacy Dr, Ste. B3-333. Plano, TX 75024	Location:	Palm Springs, CA	
Phone:	(972) 896-7373	Model:	MarquiCanopy	
Email:	yurianto@modularconsultant.com	Date:	12/30/2019	Final

**DESIGN CRITERIA**

Design load code ASCE 7-16

Roof Live Load      Min. Uniform load       $L_{o\ roof} = 5$  psf      Reduction permitted?      No  
                                  Min. Concentrated load       $L_{conc} = 300$  lb      Applied to skeleton structure

Wind Load

Note:

Design Situation	Frame <u>with</u> fabric
Risk category	I
Wind exposure category	B
Basic wind speed	$V = 75$ mph
Ground elevation above sea level	$z_g = 479$ ft
Wind importance factor	$I_w = 1.00$
Gust-effect factor	$G = 0.85$
Wind exposure category	$K_{zf} = 0.57$
Ground Elevation Factor	$K_e = 0.98$
Wind Directional Factor	$K_d = 0.85$
Internal Pressure Coefficient	$(G C_{pi}) = +/- 0.55$
Topographic factor	$K_{zt} = 1.0$
Mean roof velocity pressure	$q_h = 6.91$ psf

Company:	Modular Structural Consultants, LLC	Project Number:	UC19009	MSC# UC19009
Engineer:	Yuri Yurianto, S.E., P.E., M.Sc.	Project Name:	Event Tent	
Address:	5760 Legacy Dr, Ste. B3-333. Plano, TX 75024	Location:	Palm Springs, CA	
Phone:	(972) 896-7373	Model:	MarquiCanopy	
Email:	yurianto@modularconsultant.com	Date:	12/30/2019	Final

**LIVE LOAD**

Roof Live Load

[Section 4.8. pg. 17]

Design load code	ASCE 7-16			
Roof type	Canopies - Fabric construction supported by a skeleton structure.			
Roof shape	Flat or Pitched			
Pitched roof angle	$\theta =$	54.46	degrees	
Min. Uniform load	$L_{o\ roof} =$	5	psf	Reduction permitted ? No [Table 4.3-1, pg. 15]
Min. Concentated load	$L_{conc} =$	300	lb	Applied to skeleton structure

Note: Uniform load is to be applied on horizontal projection supported by the member



Company:	Modular Structural Consultants, LLC	Project Number:	UC19009	MSC# UC19009
Engineer:	Yuri Yurianto, S.E., P.E., M.Sc.	Project Name:	Event Tent	
Address:	5760 Legacy Dr, Ste. B3-333, Plano, TX 75024	Location:	Palm Springs, CA	
Phone:	(972) 896-7373	Model:	MarquiCanopy	
Email:	yurianto@modularconsultant.com	Date:	12/30/2019	Final

WIND LOAD	ID #	Main Building	
Design load code		ASCE 7-16	
Structural type		Buildings - Main Wind Force Resisting System	[Table 26.6-1, pg. 266]
Roof type		Gable	
Risk category		I	[Table 1.5-1, pg. 4]
Enclosure classification		Partially enclosed buildings	[Table 26.13-1, pg. 271]
Wind exposure category		B	[Section 26.7.3, pg. 266]
Basic wind speed		V = 75 mph	[Figure 26.5-1, pg. 247-249]
Building span		L = 30.0 ft	
Building length		B = 30.0 ft	
Roof peak height		h <sub>r</sub> = 21.0 ft	
Roof eave height		z = 10.5 ft	
Mean roof height		h = 10.5 ft	
Roof slope		θ = 54.5 degrees	y (ft) = 10.5, x (ft) = 10.5, tan θ (y/x) = 54.46
Ground elevation above sea level		z <sub>g</sub> = 479 ft	
Wind importance factor		I <sub>w</sub> = 1.00	[Table 1.5-2, pg. 5]
Gust-effect factor		G = 0.85	[Section 26.11.1, pg. 269]
Wind exposure category		K <sub>h</sub> = 2.01 (h / z <sub>g</sub> ) <sup>2/α</sup> α = 7 z <sub>g</sub> = 1200 K <sub>h</sub> = 0.57	K <sub>z</sub> = 2.01 (z / z <sub>g</sub> ) <sup>2/α</sup> α = 7 z <sub>g</sub> = 1200 K <sub>z</sub> = 0.57 [Table 26.10-1, pg. 268]
Ground Elevation Factor		K <sub>e</sub> = e <sup>-0.00036z<sub>g</sub></sup> K <sub>e</sub> = 0.98	[Table 26.9-1, pg. 268]
Wind Directional Factor		K <sub>d</sub> = 0.85	[Table 26.6-1, pg. 266]
Internal Pressure Coefficient		(G C <sub>pi</sub> ) = +/- 0.55	[Table 26.13-1, pg. 271]
Topographic factor		K <sub>zt</sub> = 1.0	[Section 26.8.2, pg. 268]
Velocity pressure		q <sub>h</sub> = 6.91 psf	q <sub>z</sub> = 6.91 psf [Eq. 26.10-1, pg. 268]
	ASCE 7-16	q <sub>h (or z)</sub> = 0.00256 K <sub>h (or z)</sub> K <sub>zt</sub> K <sub>e</sub> K <sub>d</sub> V <sup>2</sup>	

Company:	Modular Structural Consultants, LLC	Project Number:	UC19009	MSC# UC19009
Engineer:	Yuri Yurianto, S.E., P.E., M.Sc.	Project Name:	Event Tent	
Address:	5760 Legacy Dr, Ste. B3-333. Plano, TX 75024	Location:	Palm Springs, CA	
Phone:	(972) 896-7373	Model:	MarquiCanopy	
Email:	yurianto@modularconsultant.com	Date:	12/30/2019	Final

**Net Design Pressures for MWFRS - Pitched Free Roofs**

I. Wind direction normal to ridge ( $\theta \leq 45^\circ$  ;  $\gamma = 0^\circ, 180^\circ$ )

$p = q_h G C_N$  (psf)

Eq. (27.4-3) page 262]

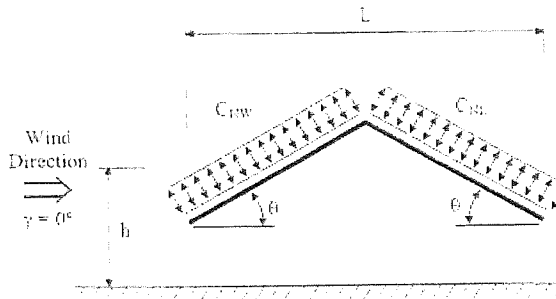

a. Clear Wind Flow

b. Obstructed Wind Flow

Case A	$p_{NW} = 6.46$ psf
	$p_{NL} = 5.29$ psf
Case B	$p_{NW} = -1.76$ psf
	$p_{NL} = -2.94$ psf

Case A	$p_{NW} = -2.94$ psf
	$p_{NL} = -2.94$ psf
Case B	$p_{NW} = -1.76$ psf
	$p_{NL} = -4.11$ psf

Plus and minus signs signify pressures acting toward and away from surfaces, respectively

II. Wind direction parallel to ridge ( $\theta \leq 45^\circ$  ;  $\gamma = 90^\circ$ )

[Fig. 27.4-7 page 270]

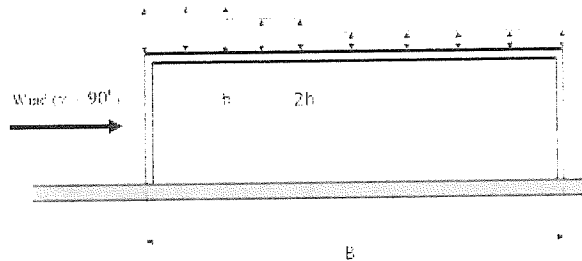
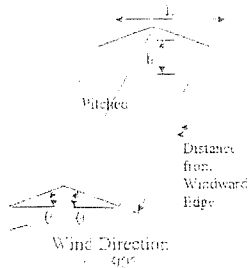

Horizontal Distance from Windward Edge

a. Clear Wind Flow

	$\leq h$	$>h, \leq 2h$	$>2h$
	Less or equal to h	More than h, less or equal to 2h	More than 2h
	$h = 10.50$ ft		$2h = 21.00$ ft
Case A	$p_K = -4.70$ psf	$p_K = -3.53$ psf	$p_K = -1.76$ psf
Case B	$p_K = 4.70$ psf	$p_K = 2.94$ psf	$p_K = 1.76$ psf

b. Obstructed Wind Flow

Case A	$p_N = -7.05$ psf	$p_N = -5.29$ psf	$p_N = -3.53$ psf
Case B	$p_N = 2.94$ psf	$p_N = 2.94$ psf	$p_N = 1.76$ psf

Company:	Modular Structural Consultants, LLC	Project Number:	UC19009	MSC# UC19009
Engineer:	Yuri Yurianto, S.E., P.E., M.Sc.	Project Name:	Event Tent	
Address:	5760 Legacy Dr, Ste. B3-333. Plano, TX 75024	Location:	Palm Springs, CA	
Phone:	(972) 896-7373	Model:	MarquiCanopy	
Email:	yurianto@modularconsultant.com	Date:	12/30/2019	Final

[ASCE 7 - Chapter 31]

## Wind Tunnel Procedure

### 31.1 SCOPE

The Wind Tunnel Procedure shall be used where required by Sections 27.1.3, 28.1.3, and 29.1.3. The Wind Tunnel Procedure shall be permitted for any building or other structure in lieu of the design procedures specified in Chapter 27 (main wind force resisting system [MWFRS] for buildings of all heights and simple diaphragm buildings with  $h \leq 160$  ft (48.8 m)), Chapter 28 (MWFRS for low-rise buildings and simple diaphragm, low-rise buildings), Chapter 29 (MWFRS for all other structures), and Chapter 30 (components and cladding [C&C] for all building types and other structures).

User Note: Chapter 31 may always be used for determining wind pressures for the MWFRS and/or for C&C of any building or other structure. This method is considered to produce the most accurate wind pressures of any method specified in this standard.

### 31.4 LOAD EFFECTS

#### 31.4.1 Mean Recurrence Intervals of Load Effects.

The load effect required for strength design shall be determined for the same mean recurrence interval as for the analytical method by using a rational analysis method, defined in the recognized literature, for combining the directional wind tunnel data with the directional meteorological data or probabilistic models based thereon. The load effect required for allowable stress design shall be equal to the load effect required for strength design divided by 1.6. For buildings or other structures that are sensitive to possible variations in the values of the dynamic parameters, sensitivity studies shall be required to provide a rational basis for design recommendations.

31.4.2 Limitations on Wind Speeds. The wind speeds and probabilistic estimates based thereon shall be subject to the limitations described in Section 26.5.3.

31.4.3 Wind Directionality. The directional wind climate based on recorded or simulated directional wind speed data shall be considered in determining wind loads and the data shall be presented as part of the wind tunnel report submitted to the Authority Having Jurisdiction. The method for combining wind tunnel model data with information on wind speed and direction at the project site shall also be clearly stated in the Wind Tunnel Report. Variation in the wind direction, based upon uncertainty in the wind climate data, shall be considered when determining the wind loading, and the design wind loads shall be based on the largest values that result from this uncertainty. Consideration of uncertainty in the wind direction is not required in the determination of serviceability related wind effects.

31.4.4 Limitations on Loads. Loads for the MWFRS determined by wind tunnel testing shall be limited such that the overall principal loads in the x and y directions are not less than 80% of those that would be obtained from Part 1 of Chapter 27 or Part 1 of Chapter 28 for buildings or Chapter 29 for other structures. The overall principal load for buildings shall be based on the overturning moment for flexible buildings and the base shear for other buildings. The overall principal load for other structures shall be based on the overturning moment for flexible structures and the base shear for other structures. Pressures for C&C determined by wind tunnel testing shall be limited to not less than 80% of those calculated for Zone 4 for walls and Zone 1 for roofs using the procedure of Chapter 30. These zones refer to those shown in Figs. 30.3-1, 30.3-2A-C, 30.3-3, 30.3-4, 30.3-5A-B, 30.3-6, 30.3-7, and 30.5-1.

The limiting values of 80% may be reduced to 50% for the MWFRS and 65% for C&C if either of the following conditions applies:

1. There were no specific influential buildings or objects within the detailed proximity model.
2. Loads and pressures from supplemental tests for all significant wind directions in which specific influential buildings or objects are replaced by the roughness representative of the adjacent roughness condition, but not rougher than Exposure B, are included in the test results.

Company: Modular Structural Consultants, LLC  
Engineer: Yuri Yurianto, S.E., P.E., M.Sc.  
Address: 5760 Legacy Dr, Ste. B3-333. Plano, TX 75024  
Phone: (972) 896-7373  
Email: yurianto@modularconsultant.com

Project Number: UC19009 MSC# UC19009  
Project Name: Event Tent  
Location: Palm Springs, CA  
Model: MarquiCanopy  
Date: 12/30/2019 Final

### Finite Element Analysis (FEA)

LC1 Form finding

#### Geometry

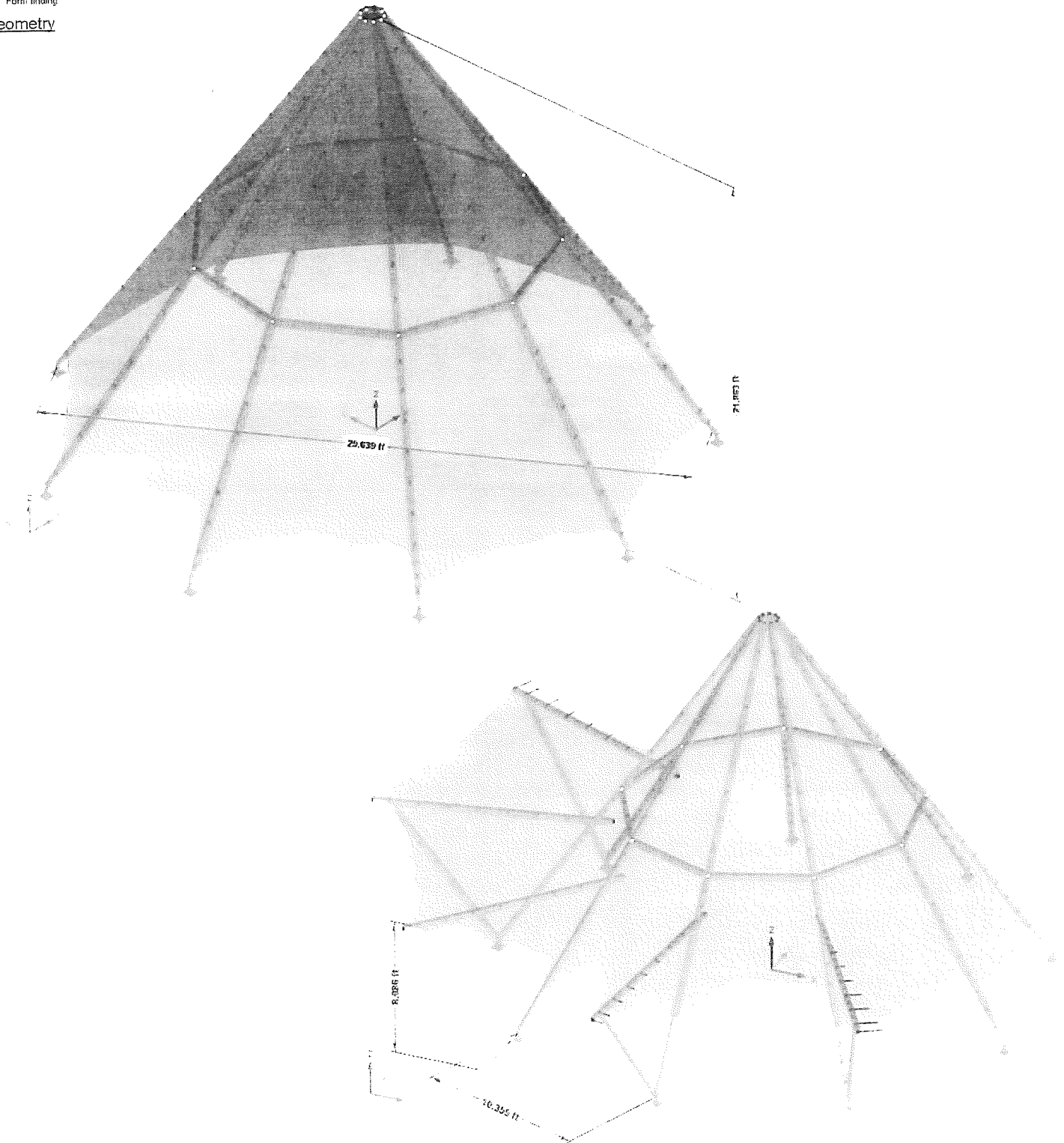

Company: Modular Structural Consultants, LLC  
Engineer: Yuri Yurianto, S.E., P.E., M.Sc.  
Address: 5760 Legacy Dr. Ste. B3-333. Plano, TX 75024  
Phone: (972) 896-7373  
Email: yurianto@modularconsultant.com

Project Number: UC19009 MSC# UC19009  
Project Name: Event Tent  
Location: Palm Springs, CA  
Model: MarquiCanopy  
Date: 12/30/2019 Final

Timber AWC Check

ID : Frame with fabric

Load Combination **IBC Section 1605.3.1 (ASD)**

Max Design Ratio [-]  
RF-TIMBER AWC CA3

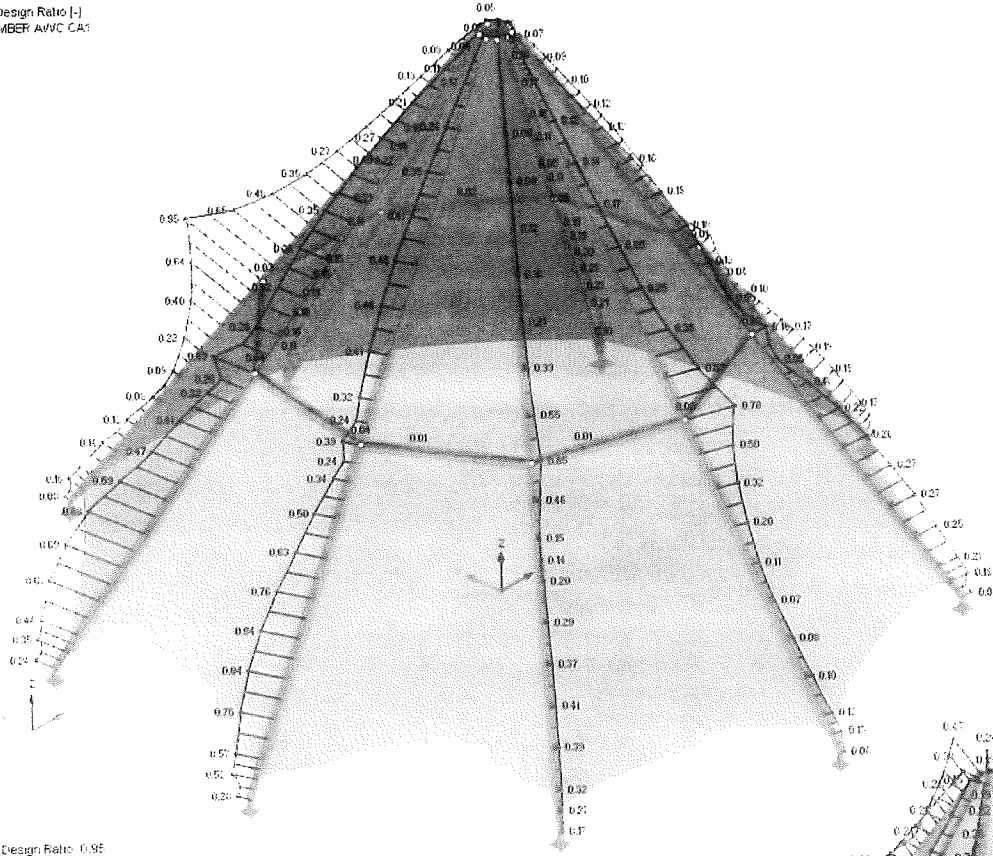

Max Design Ratio: 0.95

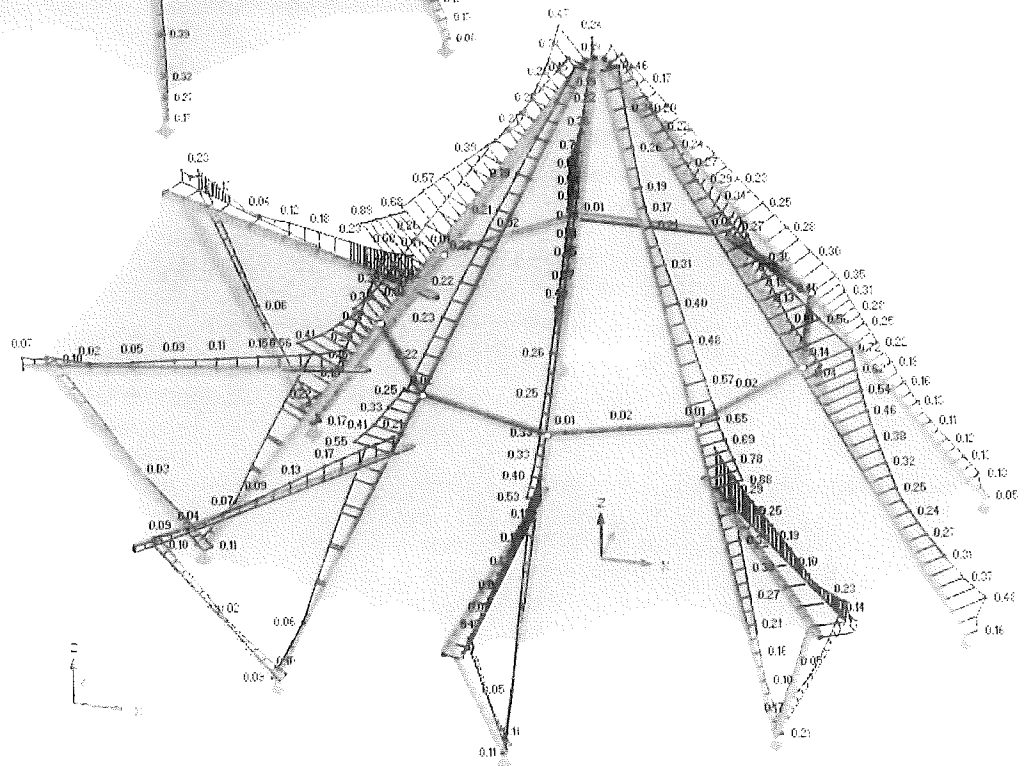

Max Design Ratio: 0.86

Company: Modular Structural Consultants, LLC  
 Engineer: Yuri Yurianto, S.E., P.E., M.Sc.  
 Address: 5760 Legacy Dr, Ste. B3-333. Plano, TX 75024  
 Phone: (972) 896-7373  
 Email: yurianto@modularconsultant.com

Project Number: UC19009 MSC# UC19009  
 Project Name: Event Tent  
 Location: Palm Springs, CA  
 Model: MarquiCanopy  
 Date: 12/30/2019 Final

**Support Reactions** ID : Maximum Downward Case

Global Deformation: u [in]  
 Support Reactions [lb]  
 CO2:  $\sigma = 0.6\sqrt{f'c}$

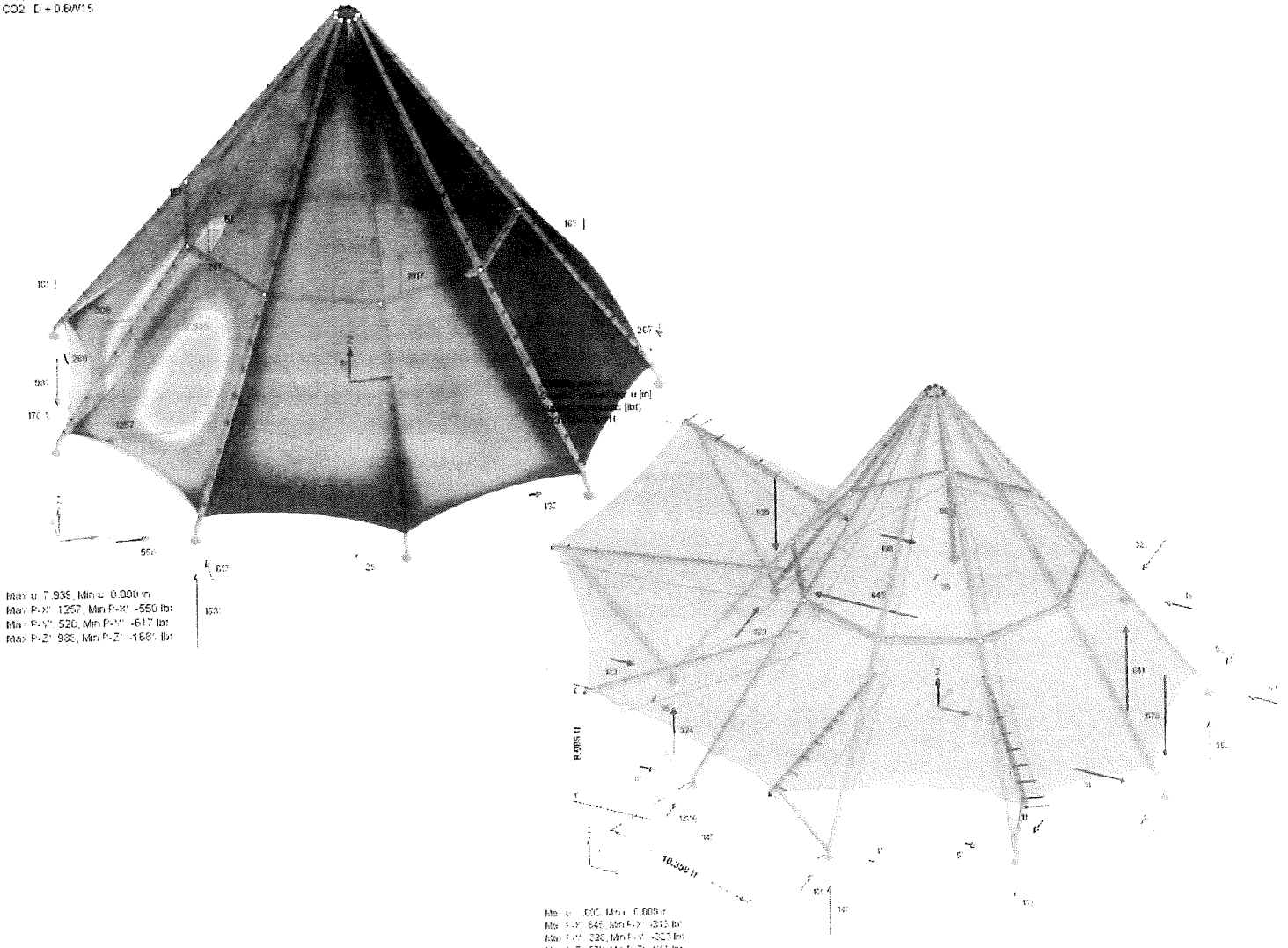

Max u: 7.936, Min u: 0.000 in  
 Max Fx: 1257, Min Fx: -550 lb  
 Max Fy: 520, Min Fy: -617 lb  
 Max Fz: 905, Min Fz: -1681 lb

Max Mx: 0.000, Min Mx: 0.000 lb-ft  
 Max My: 645, Min My: -313 lb-ft  
 Max Mz: 320, Min Mz: -325 lb-ft  
 Max Fz: 570, Min Fz: -1641 lb

Column Label	Node No.	IBC Section 1605.2 (ASD)						IBC Section 1605.2 (LRFD)					
		Support Forces (lb)			Support Moment (lb-ft)			Support Forces (lb)			Support Moment (lb-ft)		
		P <sub>x</sub>	P <sub>y</sub>	P <sub>z</sub>	M <sub>x</sub>	M <sub>y</sub>	M <sub>z</sub>	P <sub>x</sub>	P <sub>y</sub>	P <sub>z</sub>	M <sub>x</sub>	M <sub>y</sub>	M <sub>z</sub>
	5	-197	133		0	0	0						
	7	-349	42		0	0	0						
	11	-283	-101		0	0	0						
	14	164	520	-1017	0	0	0						
	18	51	-241		0	0	0						
	37	508	-268		0	0	0						
	248	1257	170		0	0	0						
	289	-550	-617	-1681	0	0	0						
	330	-29	343		0	0	0						

Company: Modular Structural Consultants, LLC  
 Engineer: Yuri Yurianto, S.E., P.E., M.Sc.  
 Address: 5760 Legacy Dr, Ste. B3-333, Plano, TX 75024  
 Phone: (972) 896-7373  
 Email: yurianto@modularconsultant.com

Project Number: UC19009 MSC# UC19009  
 Project Name: Event Tent  
 Location: Palm Springs, CA  
 Model: MarquiCanopy  
 Date: 12/30/2019 Final

**Support Reactions**

ID: Maximum Uplift Case

Global Deformations u [in]  
 Support Reactions [lb]  
 COS: 0.60 = 0.6W15

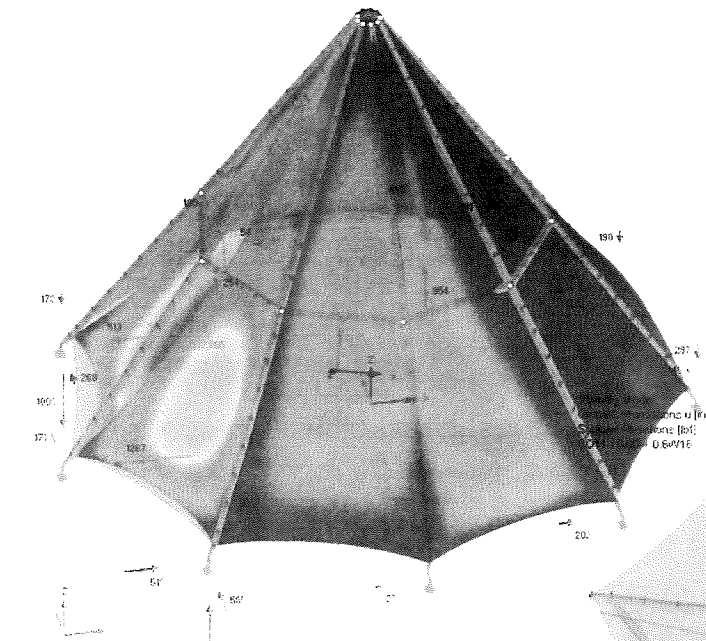

Max: u: 7.685, Min: u: 0.000 in.  
 Max: F<sub>x</sub>: 1267, Min: F<sub>x</sub>: -515 lb  
 Max: F<sub>y</sub>: 480, Min: F<sub>y</sub>: -585 lb  
 Max: F<sub>z</sub>: 1005, Min: F<sub>z</sub>: -1612 lb

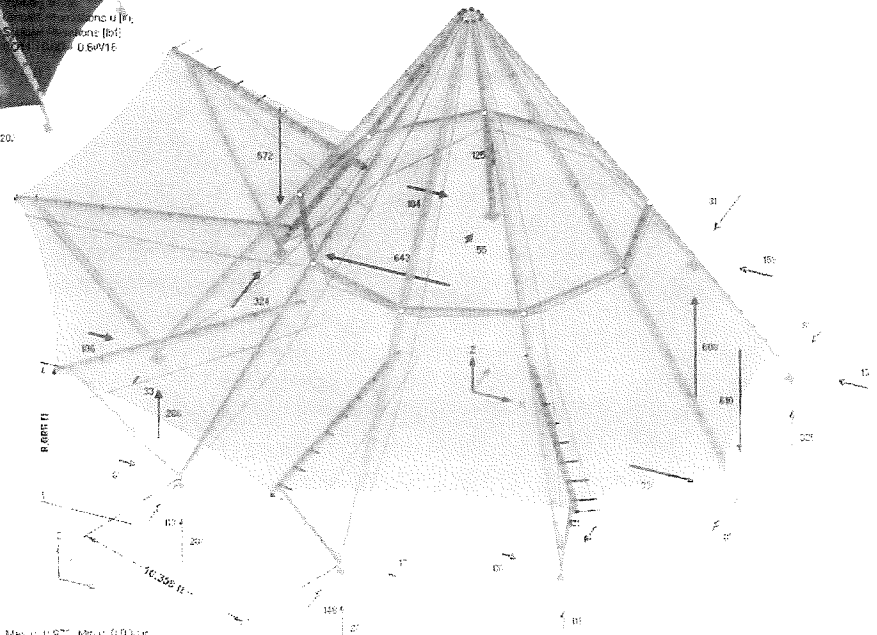

Max: u: 0.972, Min: u: 0.000 in.  
 Max: F<sub>x</sub>: 642, Min: F<sub>x</sub>: -330 lb  
 Max: F<sub>y</sub>: 311, Min: F<sub>y</sub>: -324 lb  
 Max: F<sub>z</sub>: 610, Min: F<sub>z</sub>: -508 lb

Column Label	Node No.	Load Combination IBC Section 1605.3.2 (ASD)						Load Combination IBC Section 1605.2 (LRFD)					
		Support Forces (lb)			Support Moment (lb-ft)			Support Forces (lb)			Support Moment (lb-ft)		
		P <sub>x</sub>	P <sub>y</sub>	P <sub>z</sub>	M <sub>y</sub>	M <sub>v</sub>	M <sub>z</sub>	P <sub>x</sub>	P <sub>y</sub>	P <sub>z</sub>	M <sub>y</sub>	M <sub>v</sub>	M <sub>z</sub>
	5	-202	142		0	0	0						
	7	-369	45		0	0	0						
	11	-299	-110		0	0	0						
	14	151	480	-954	0	0	0						
	18	58	-254		0	0	0						
	37	513	-268		0	0	0						
	248	1267	171		0	0	0						
	289	-519	-585	-1612	0	0	0						
	330	-27	359		0	0	0						



**American Earth Anchors**

The best screw you will have in the dirt!

**LOAD CAPACITY**

**Cabled Anchors**  
Bullets and Arrowheads

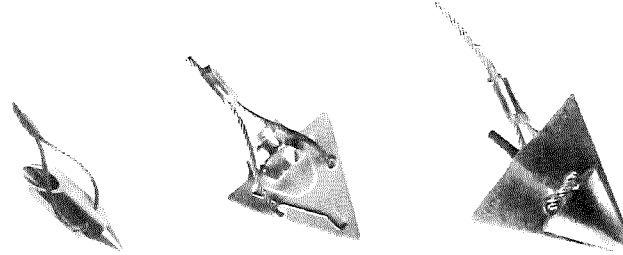

CABLED ANCHORS	Bullets		Steel arrowheads		Aluminum mil-spec arrowheads						
	Thimble loop or cable clamps	Quickvise or disk + Quickvise	Thimble loop or cable clamps	Quickvise or disk + Quickvise	Thimble loop or cable clamps	Quickvise or disk + Quickvise	Thimble loop or cable clamps	Thimble loop or cable clamps	Thimble loop or cable clamps	Thimble loop or cable clamps	
<b>LOAD CAPACITY</b> Pounds											
Field-tested pullout resistance											
	Minimum depth 2'	Minimum depth 2'	Minimum depth 2'	Minimum depth 2'	Minimum depth 2.5'	Minimum depth 2.5'	Minimum depth 2.5'	Minimum depth 3.5'	Minimum depth 4'	Minimum depth 5'	
	3"	3"	3"	3"	4"	4"	4"	6"	8"	10"	
<b>SOIL CLASSIFICATION</b> per ASTM D-2487/2488											
Hardpan Asphalt	2,000 lb	1,100 lb	2,000 lb	1,100 lb	3,500 lb	3,150 lb	3,500 lb	5,000 lb	9,000 lb	14,000 lb	
Sandy gravel Very dense sand	1,800 lb	1,100 lb	1,800 lb	1,100 lb	2,200 lb	2,200 lb	2,200 lb	3,000 lb	6,500 lb	11,000 lb	
Silty or clayey sand Silty gravel	1,700 lb	1,100 lb	1,700 lb	1,100 lb	1,900 lb	1,900 lb	1,900 lb	2,000 lb	3,500 lb	7,000 lb	
Loose to med dense sands Loose sands	600 lb	600 lb	600 lb	600 lb	900 lb	900 lb	900 lb	1,200 lb	2,200 lb	4,000 lb	
Firm clays	350 lb	350 lb	350 lb	350 lb	475 lb	475 lb	475 lb	600 lb	1,250 lb	2,400 lb	
Uncompacted fill											

©2017 American Earth Anchors

[americaneearthanchors.com](http://americaneearthanchors.com)

[info@americanea.com](mailto:info@americanea.com)

866-520-8511

USE

3AL-3TH

OR

3ST-3TH



## About LOAD CAPACITY

Determining load capacity is an inexact science limited by an inexact environment, but carefully conducted testing can provide useful decision-making data. A further awareness of the many variables involved can guide an informed choice of an effective anchoring solution.

Due to the array of unknowns both below and above the surface of any anchoring application – the soil medium, installation method, local climate, connections to the anchored structure – no one can guarantee a specific holding strength. Our published load capacity numbers, tested in actual field conditions to the best standards that real dirt can provide, are offered as an informed guideline, not a guarantee.

Load capacity is not a simple function of “soil class” (the general type of soil, listed at the lower left of these strength charts) but also of real-time moisture content, compaction, root penetration, installation method, pullout load angle, and other factors unique to the installation’s time and place.

The only method of accurately predicting the load capacity of an anchor at a specific site is by an on-site proof test of the anchor under local conditions, installed and loaded in the same manner as the intended application.

Please contact us with any questions you may have about the challenges, unknowns, and choices involved in your anchoring application.

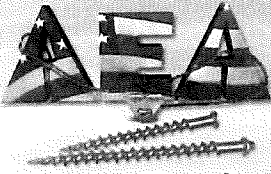

# American Earth Anchors

*The best screw you will have in the dirt™*

americaneearthanchors.com

QUICK REFERENCE

## 3AL-36TH | Specifications

### 3" bullet with 3' cable and thimble

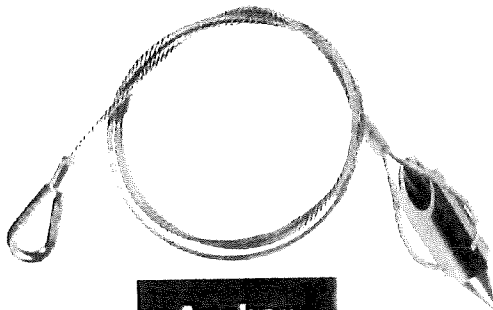

**Anchor**

Anodized cast aluminum

- Aircraft-quality 356 alloy
- Heat-treated to T6 specification

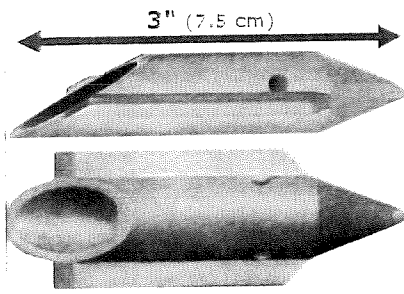

3" (7.5 cm)

1 1/4" (3.2 cm)

3/4" (2 cm)

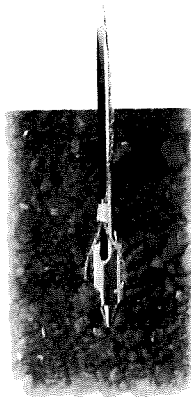

### Bullets

All have the same bullet anchor, with different cable lengths or type of cable termination



### Bullet vs. arrowhead

Streamlined bullet shape is designed for driving through compact or stony soils, gravel, hard clay, and other dense or difficult conditions

.5 lb  
(.23 kg)



### Cable

Galvanized steel aircraft cable



Diameter: 1/8" (3 mm)

Length: 3' (.9 m)

Breaking strength:  
2,000 lb (8.9 kN)

Available in stainless steel as special order

### Thimble

Galvanized steel

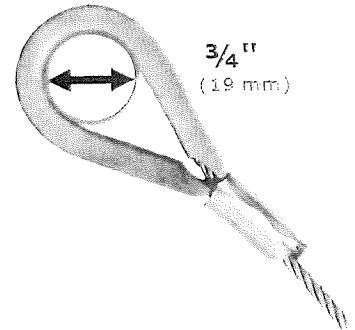

3/4" (19 mm)

## LOAD CAPACITY

Pullout strength at MINIMUM DEPTH 2' (.6 m)

Soil Class 1	Soil Class 2	Soil Class 3	Soil Class 4	Soil Class 4
Hardpan Asphalt	Sandy gravel Very dense sand	Silty/clayey sand Silty gravel	Loose/med dense sands Loose sands Firm clays	Loose fine un- compacted sand
<b>2,000 lb</b> 8.90 kN	<b>1,800 lb</b> 8.01 kN	<b>1,700 lb</b> 7.56 kN	<b>600 lb</b> 2.67 kN	<b>350 lb</b> 1.56 kN

Soil classification per ASTM D-2487/2488



American Earth Anchors  
info@americanaea.com  
americaneearthanchors.com

### Contact us for CUSTOM WORK

Size, length, shape, material,  
prototypes, cable assemblies



866-520-8511

+1 508-520-8511

# 3AL-36TH | Installation



Don't use rebar - it can get stuck in the bullet!

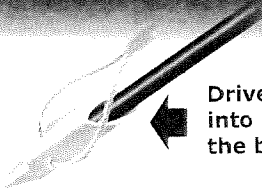

Drive rod fits into back of the bullet

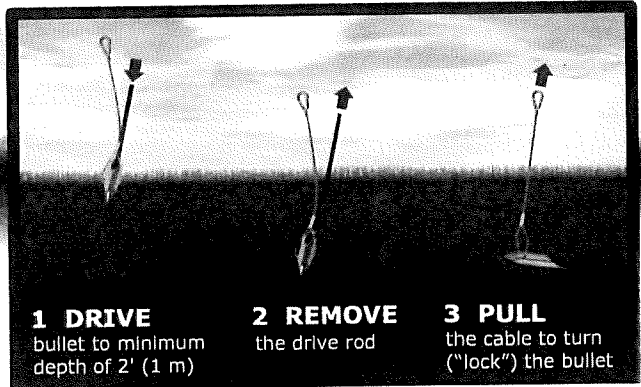

**1 DRIVE**  
bullet to minimum depth of 2' (1 m)

**2 REMOVE**  
the drive rod

**3 PULL**  
the cable to turn ("lock") the bullet

## Into the ground

3' (.9 m) drive rod

1/2" (13 mm) diameter

DR-3ST

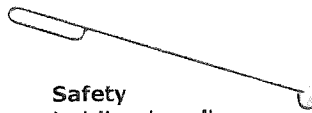
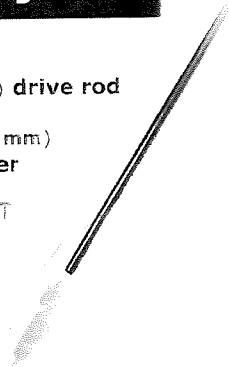

Safety holding handle

DR-SHH

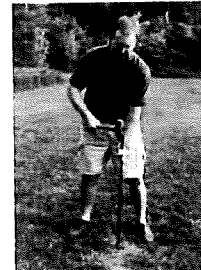

Sledge hammer



Demolition hammer

## Locking the anchor



During locking, anchor will pull up as it turns, settles, and locks. Depending on soil type, this can typically be 1-4 inches (3-10 cm).

### SIMPLE PULL

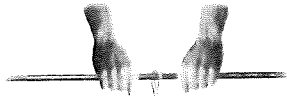

Put drive rod through thimble and PULL

Most common method for this size anchor



### LEVERAGE (Manual)

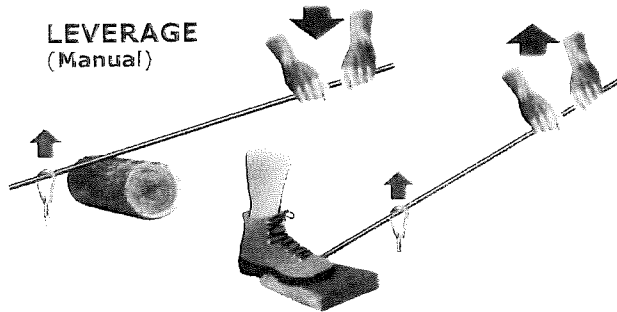

### LEVERAGE (Mechanical)

Not usually needed for this size anchor



Ratchet-lever hoist ("come-along")



Bumper jack

## Through asphalt

Drill PILOT HOLE through asphalt

1" (2.5 cm) diameter

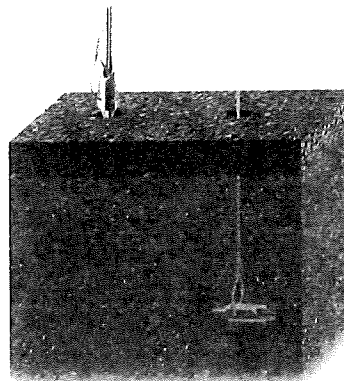
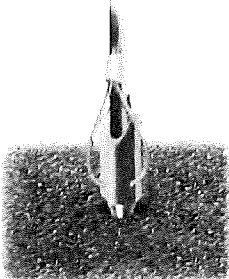

## Non-vertical load

Install at same angle as load for maximum pullout strength

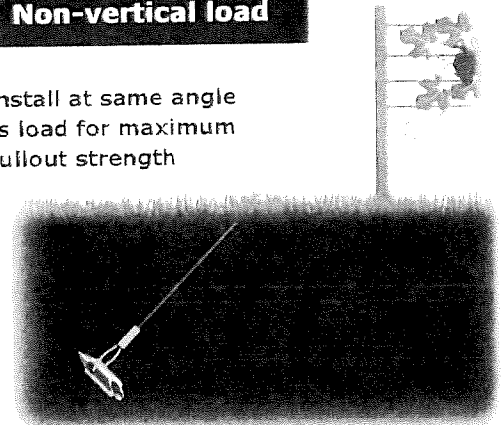

American Earth Anchors  
info@americanea.com  
americaneearthanchors.com

Contact us for **CUSTOM WORK**  
Size, length, shape, material,  
prototypes, cable assemblies



866-520-8511



+1 508-520-8511

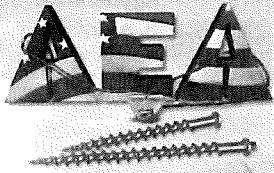

# American Earth Anchors

The best screw you will have in the dirt™

americaneearthanchors.com

QUICK REFERENCE

## 3ST-36TH | Specifications

### 3" steel arrowhead with 3' cable and thimble

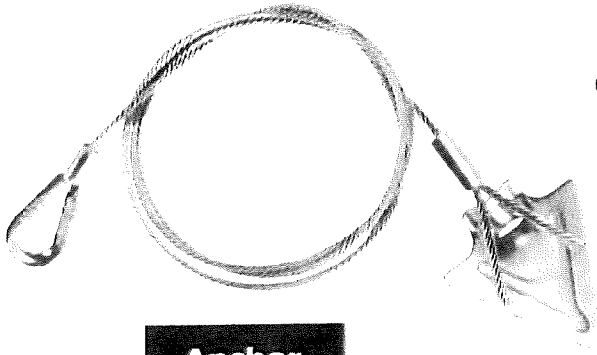

.32 lb  
(.15 kg)



#### Steel Arrowheads

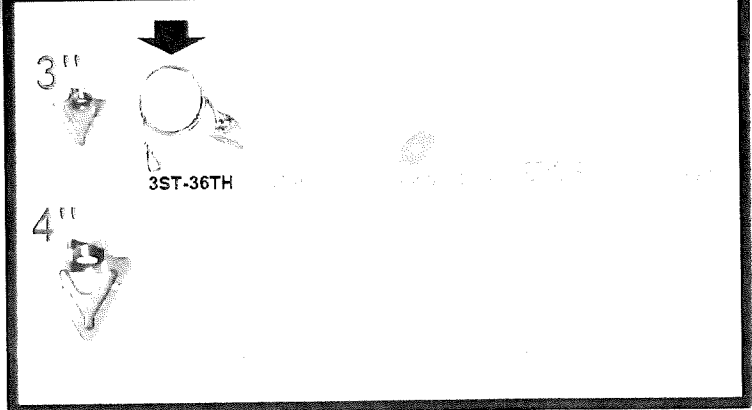

#### Anchor

Galvanized steel

3" (7.5 cm)

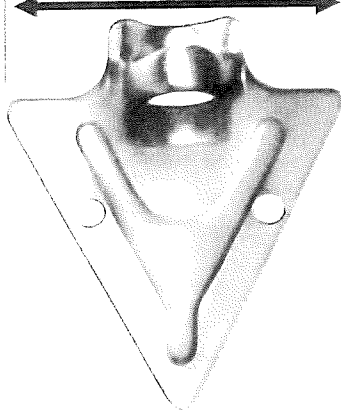

#### Cable

Galvanized steel  
aircraft cable



Diameter: 1/8" (3 mm)

Length: 3' (.9 m)

Breaking strength:  
2,000 lb (8.9 kN)

Available in stainless steel  
as special order

#### Thimble

Galvanized steel

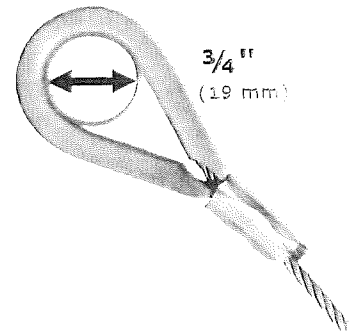

3/4"  
(19 mm)

### LOAD CAPACITY

Pullout strength at MINIMUM DEPTH 2' (.6 m)

Soil Class 1	Soil Class 2	Soil Class 3	Soil Class 4	Soil Class 4
Hardpan Asphalt	Sandy gravel Very dense sand	Silty/clayey sand Silty gravel	Loose/med dense sands Loose sands Firm clays	Loose fine un- compacted sand
2,000 lb 8.90 kN	1,800 lb 8.01 kN	1,700 lb 7.56 kN	600 lb 2.67 kN	350 lb 1.56 kN

Soil classification per ASTM D-2487/2488



American Earth Anchors  
info@americanea.com  
americaneearthanchors.com

#### Contact us for CUSTOM WORK

Size, length, shape, material,  
prototypes, cable assemblies



866-520-8511



+1 508-520-8511

# 3ST-36TH | Installation



Don't use rebar - it can get stuck in the anchor!

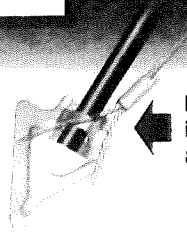

Drive rod fits into back of arrowhead

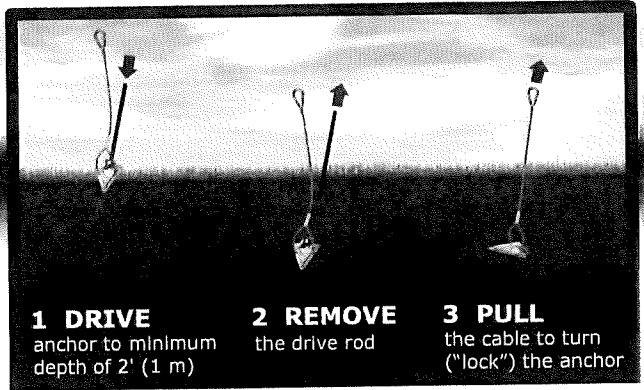

**1 DRIVE**  
anchor to minimum depth of 2' (1 m)

**2 REMOVE**  
the drive rod

**3 PULL**  
the cable to turn ("lock") the anchor

## Into the ground

3' (.9 m) drive rod

1/2" (13 mm) diameter

DR-3ST

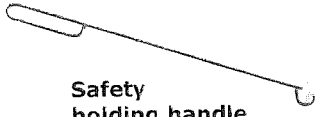

Safety holding handle

DR-SHH



Sledge hammer



Demolition hammer

## Locking the anchor



During locking, anchor will pull up as it turns, settles, and locks. Depending on soil type, this can typically be 1-4 inches (3-10 cm).

### SIMPLE PULL

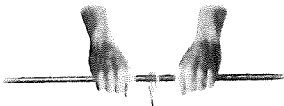

Put drive rod through thimble and PULL

Most common method for this size anchor



### LEVERAGE (Manual)

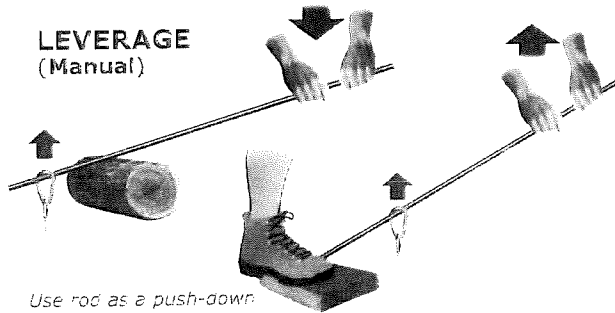

Use rod as a push-down or pull-up lever

### LEVERAGE (Mechanical)

Not usually needed for this size anchor



Ratchet-lever hoist ("come-along")

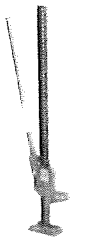

Bumper jack

## Through asphalt

Make slot through asphalt

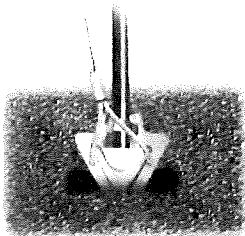

One method: Jackhammer with chisel

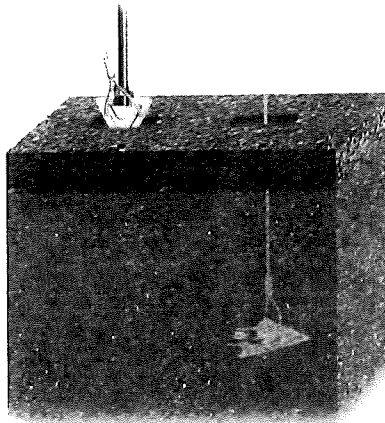

## Non-vertical load

Install at same angle as load for maximum pullout strength

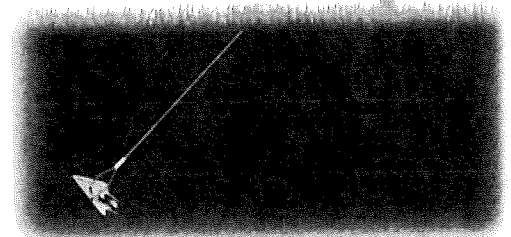

American Earth Anchors  
info@americanea.com  
americanearthanchors.com

### Contact us for CUSTOM WORK

Size, length, shape, material,  
prototypes, cable assemblies



866-520-8511



+1 508-520-8511



Email us at

[events@undercanvas.com](mailto:events@undercanvas.com)

to learn about our pop-up experience today!

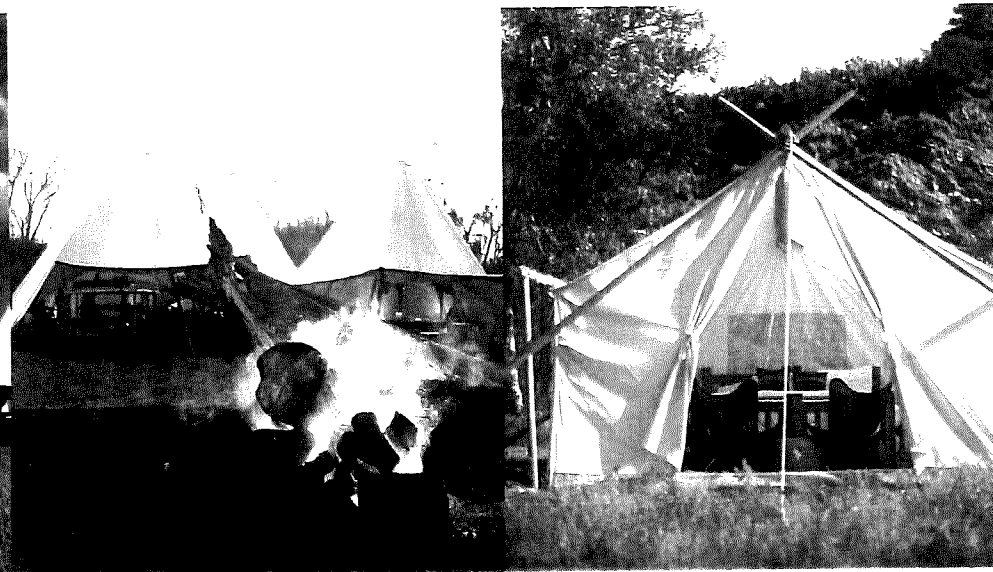

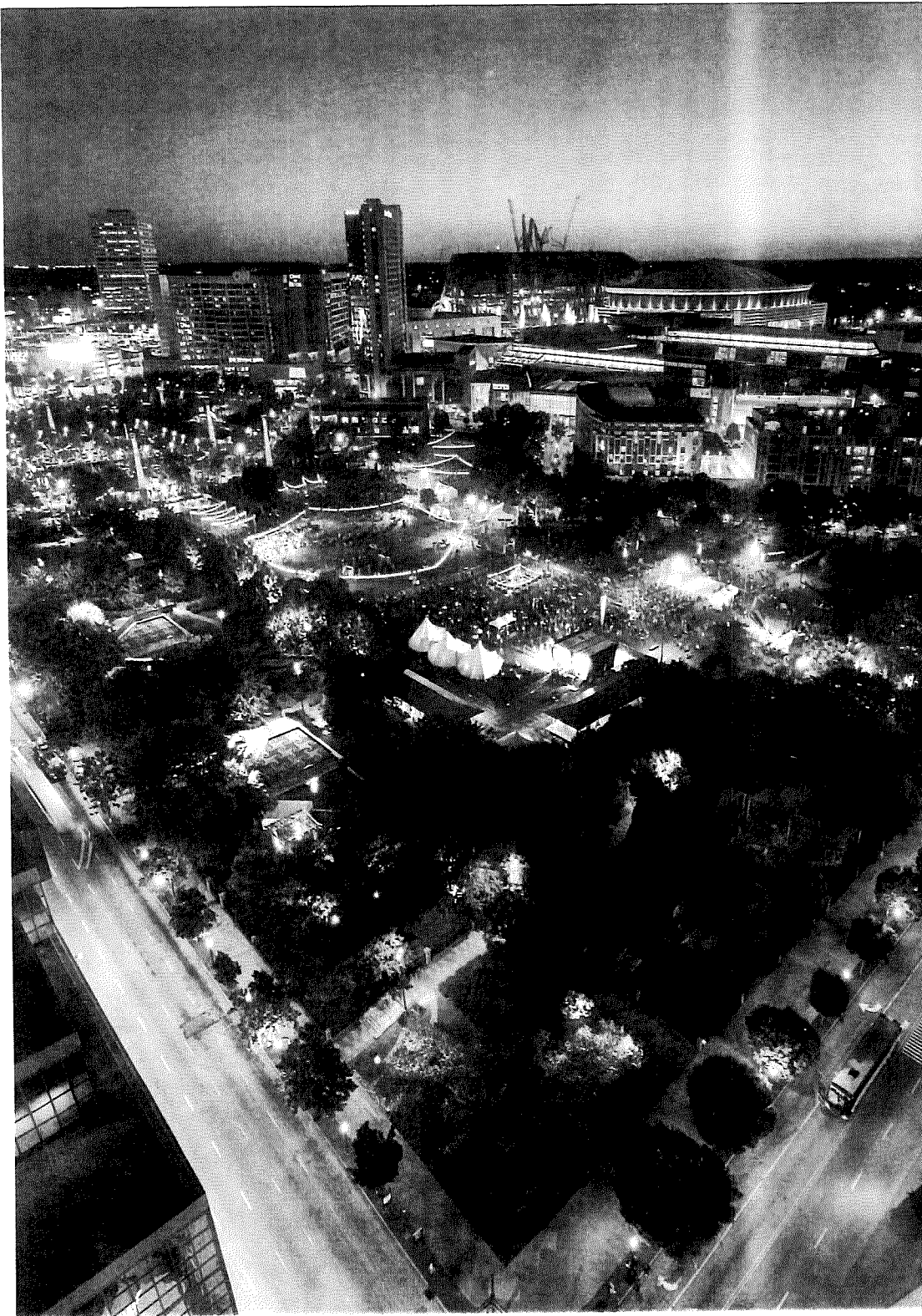

# Furnishings



Coat Stand

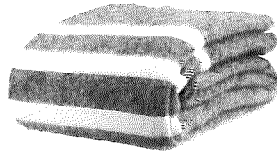

Wool Blankets



Lanterns



Cowhide Rugs



Folding Chair

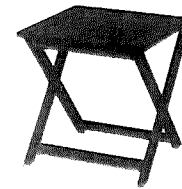

Folding Footstool

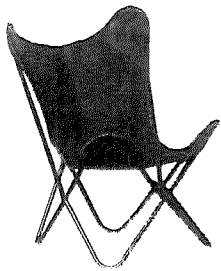

Butterfly Chair



Bedside Table

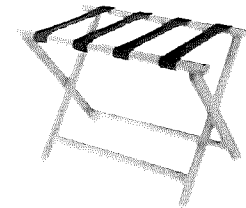

Luggage Rack



# Safari Tent Pricing

## Pricing Range

Prices decrease as your order increases

Each tent comes fully equipped with luxury finishes  
Bedding options include:

- 1 King bed | 2 Twin beds | 3 Twin beds | 4 Twin beds
- 1 King bed | 2 Twin beds | 3 Twin beds | 4 Twin beds
- 1 King bed | 2 Twin beds | 3 Twin beds | 4 Twin beds

Custom pricing available for long term rentals

All prices are before labor, shipping and tax (where applicable) - rates are for 5 days

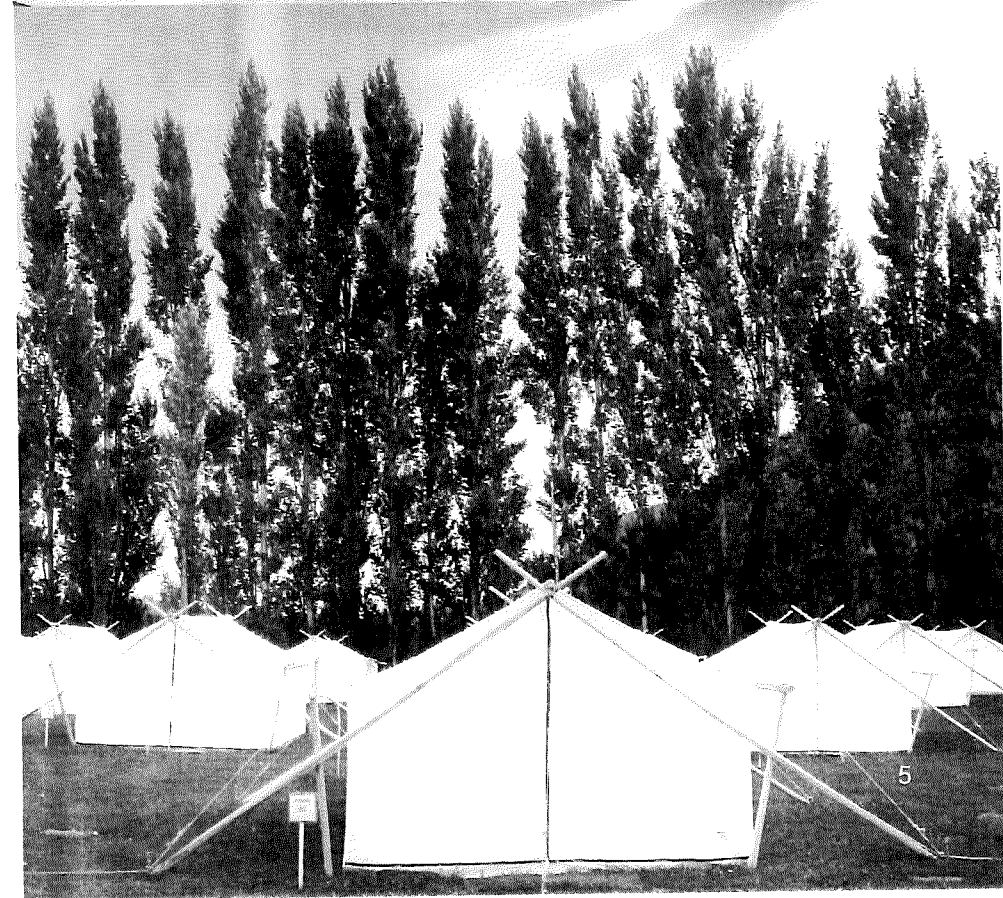

# CanopyMarqui™ Pricing

## Pricing Range

CanopyMarqui tents can be conjoined to accommodate any sized party.

All prices are before labor, shipping and tax (where applicable). Rates are for 5 days.

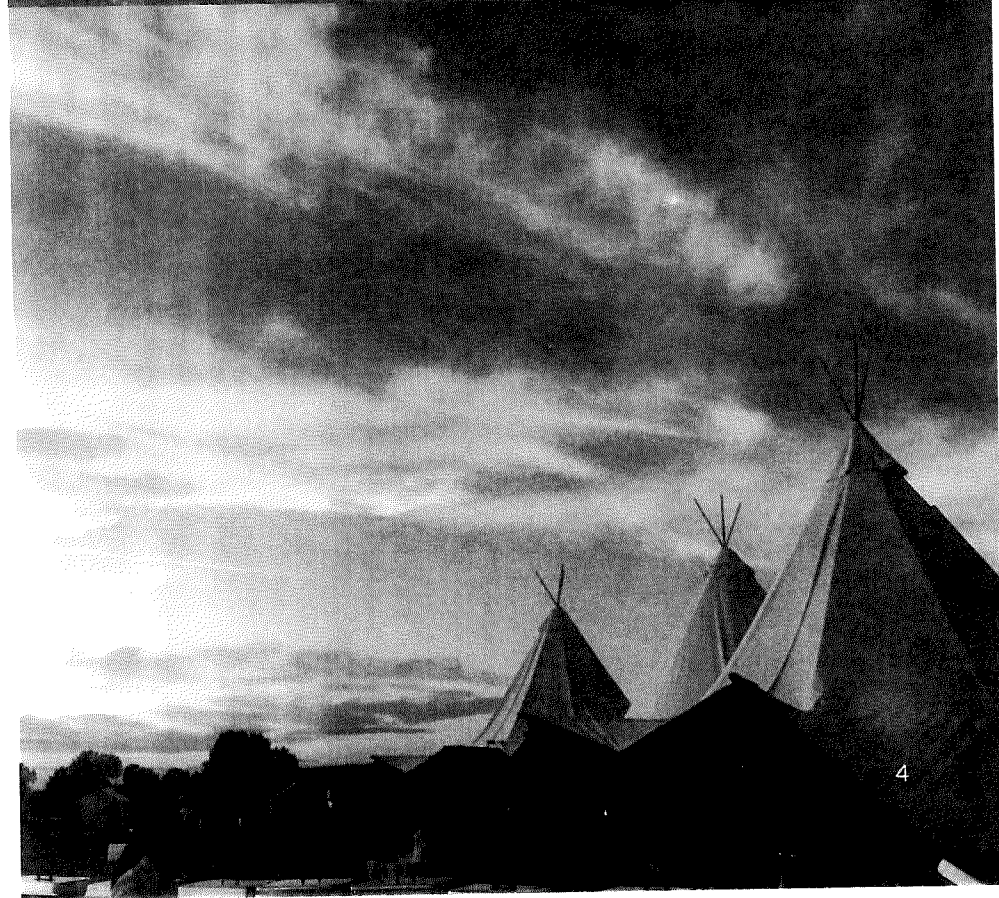
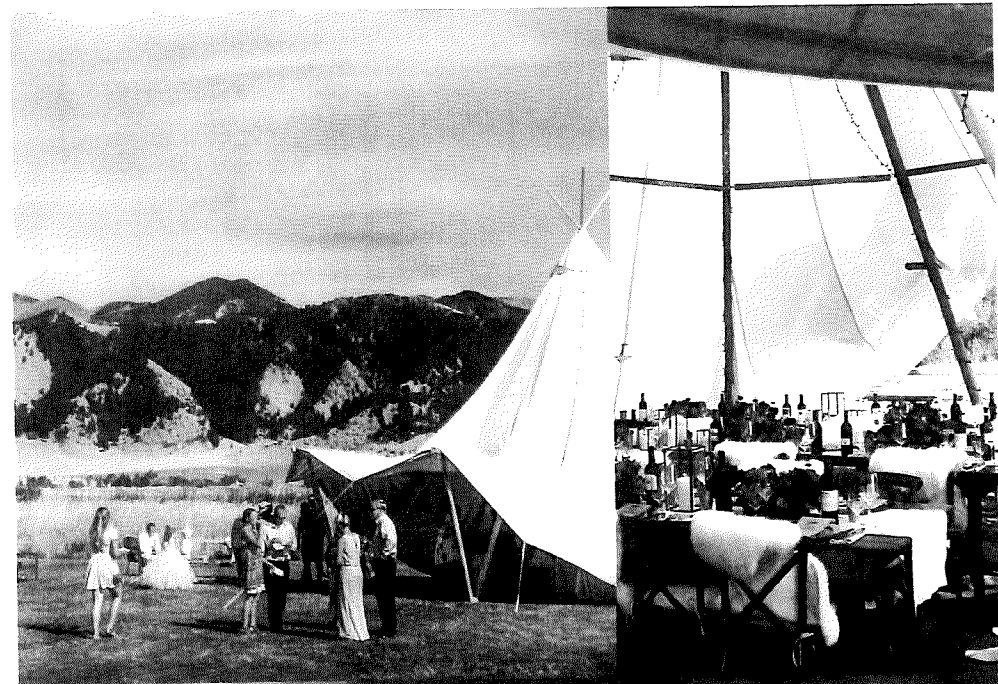

# CanopyMarqui™

## Sample layouts

Lounge Seating with Firepit

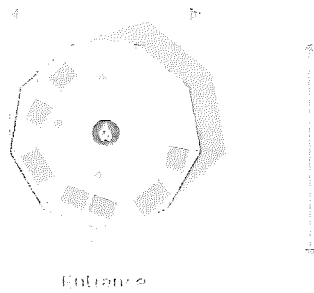

Lounge Seating



Farm Table

Round Table (6 seats)

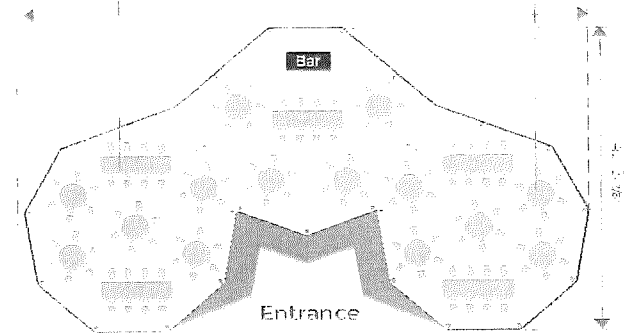

5 Round table  
30 chairs

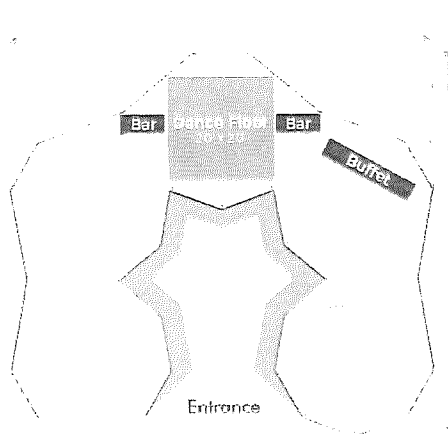

Lounge Area  
with Fire Pit

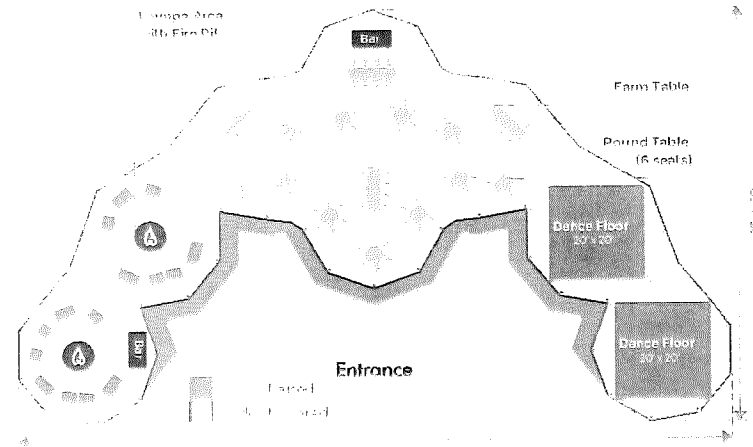

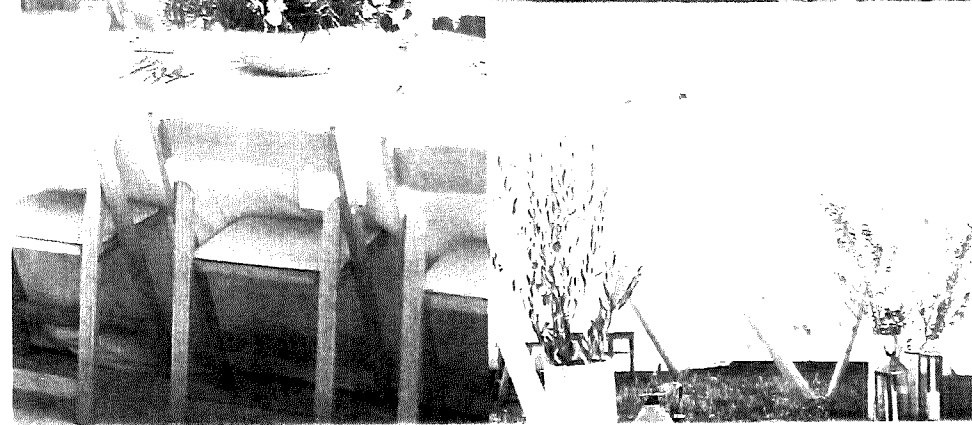
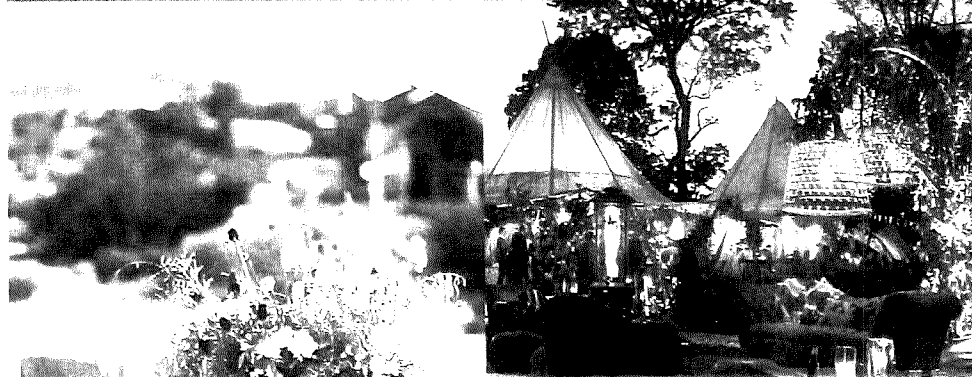
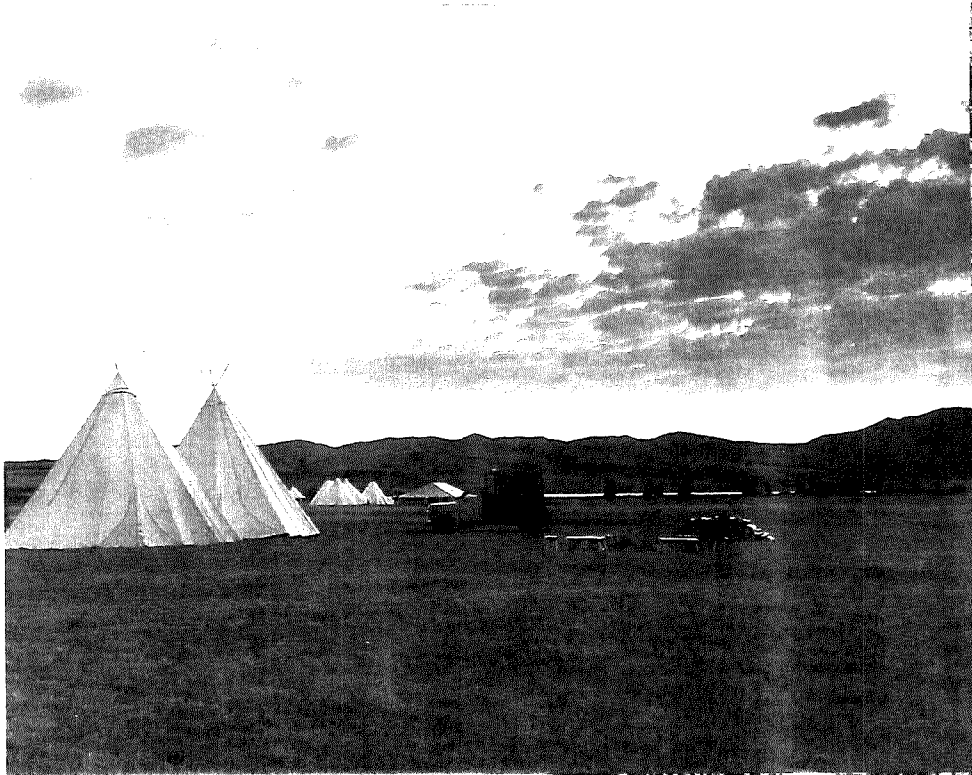



UNDER CANVAS

POP-UP  
EVENT RENTALS

---

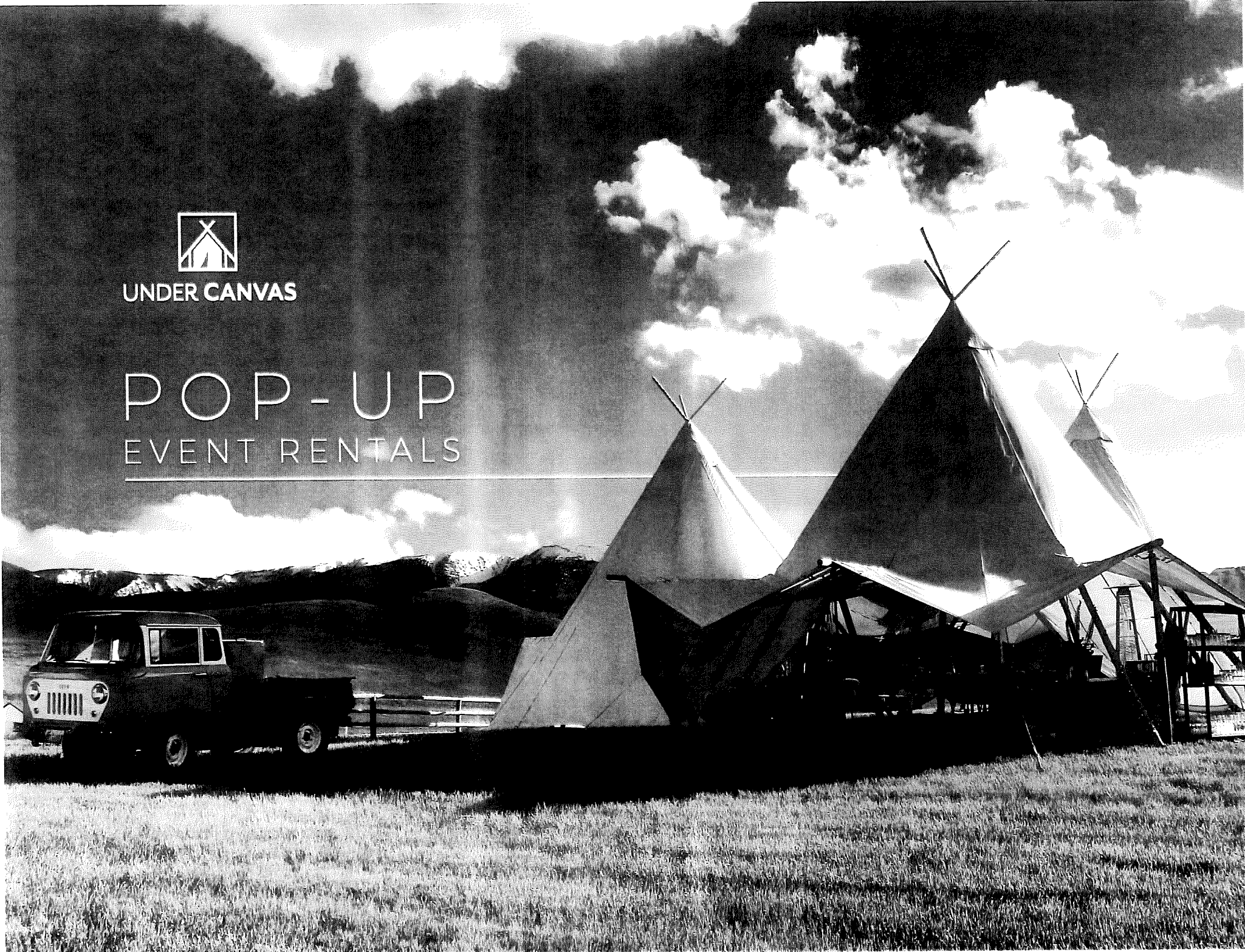

## Stage Max Load

Dustie Eleen <dustie@cruxevents.com>

Wed 8/4/2021 2:35 PM

To: Emily Srok <Emily@redcarpetdmc.com>

Hi Emily,

This is what I've been able to find regarding the max load of the stage for the Oct. 15th event:

A 4'x8' Portable Stage Panel has a standard uniform load rating of **153 lbs/sq ft**. This means the stage panel can safely support up to 153 lbs of evenly distributed weight per square foot of surface area.

I hope this is what you are looking for. Let me know if you have any questions.

--

Dustie Eleen

Accounting / Office Manager

Crux Events & Party Rents, LLC

530-587-8700 - Office

775-842-3192 - Mobile

# Marqui Tent

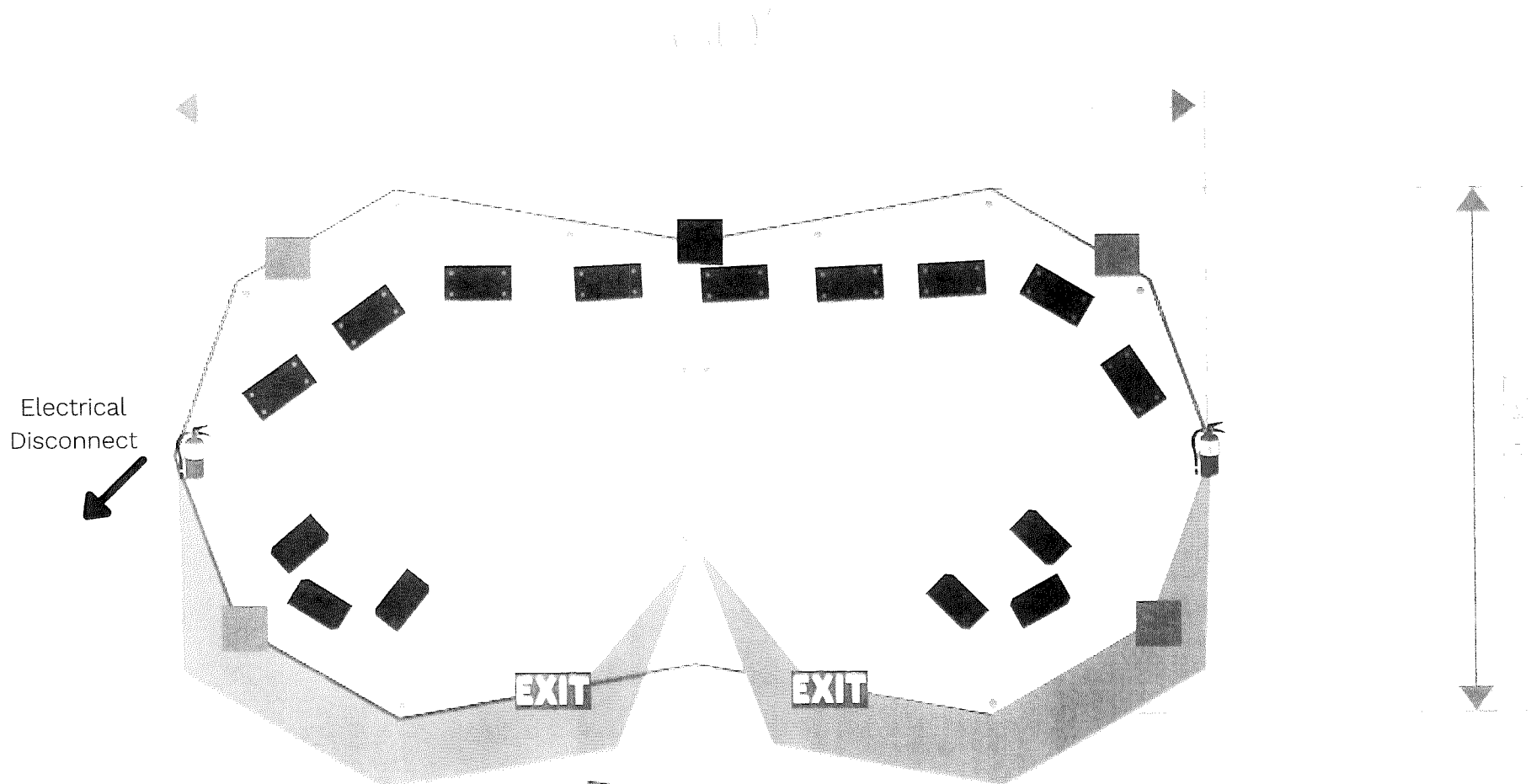

Sides Raised / Egress / Exit

Sides Lowered



Sandbags will be placed at each dotted point to secure tent



Booth - 20" deep x 55" wide (all booths will be 3ft from all sides of tent) - quantity 9



Couch groupings - 6ft long couches - quantity 6



occupant load sign



no smoking signs



Fire extinguisher quantity 2



Illuminated Exit signs will be hung - quantity 2

# SafariTent

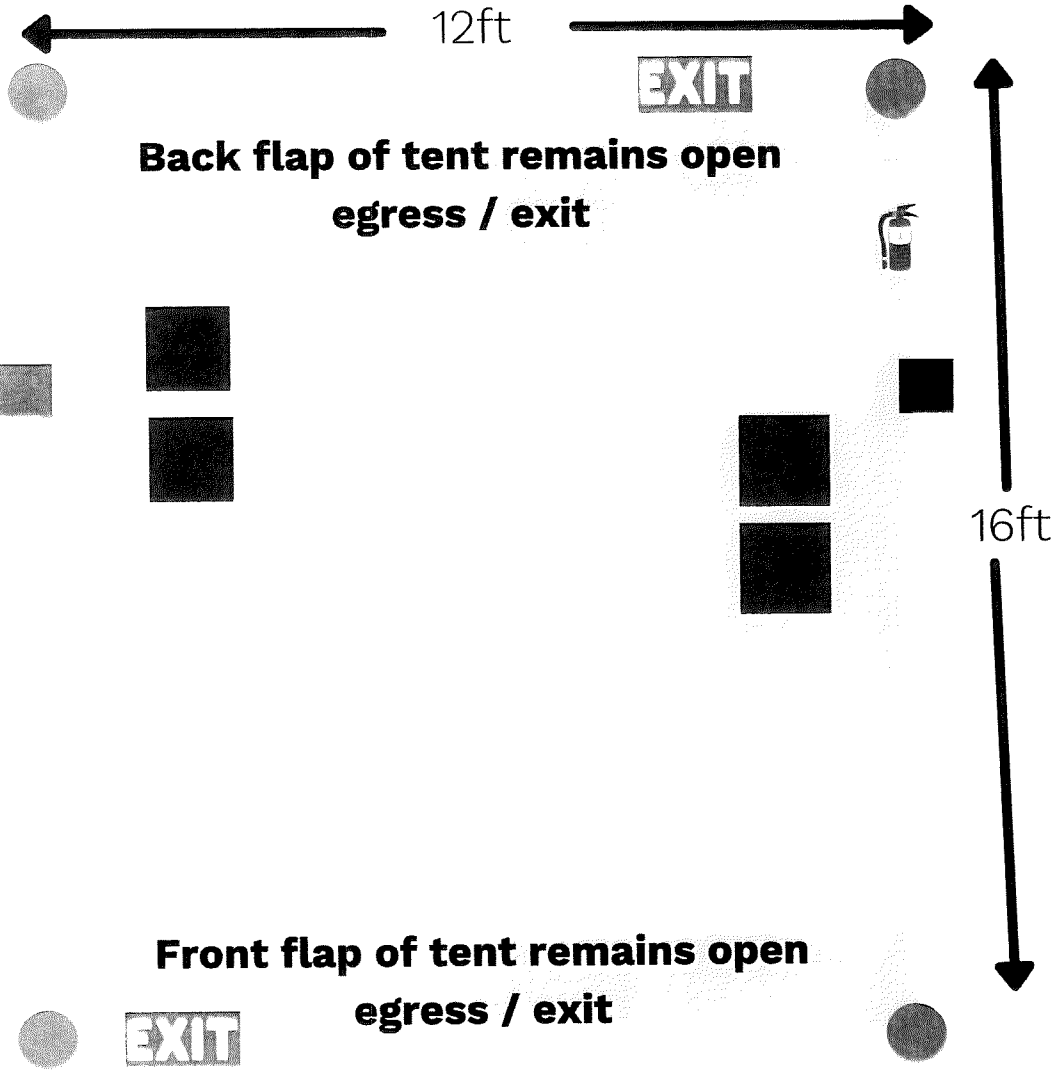

No electrical inside tent

■ Lounge Chairs - 3ft from tent drape

● Sandbags will be placed at each dotted point to secure tent

■ occupant load sign

■ no smoking signs



Fire extinguisher quantity 1



Illuminated Exit signs will be hung - quantity 2





PRODUCT CODE

ESAF

PRODUCT NAME

EVENT SAFARI - DIMENSIONS

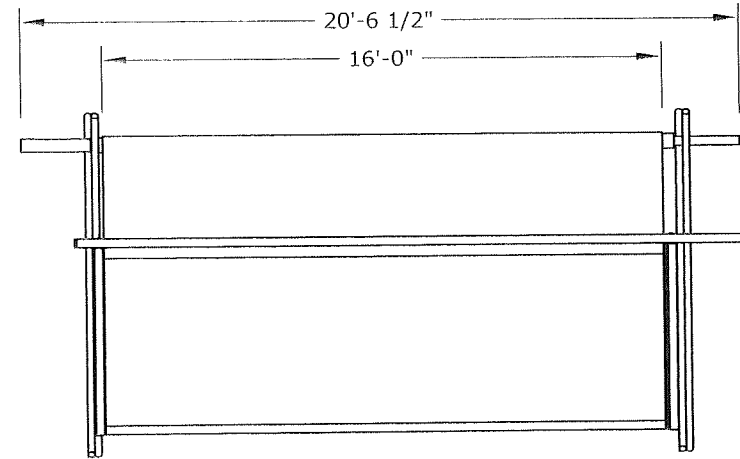
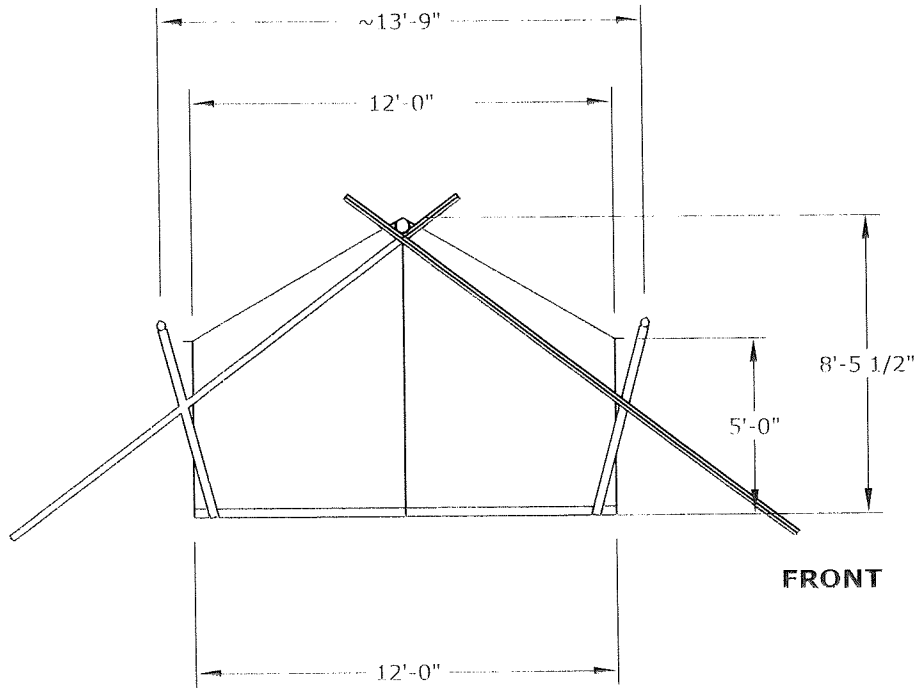

**RIGHT**

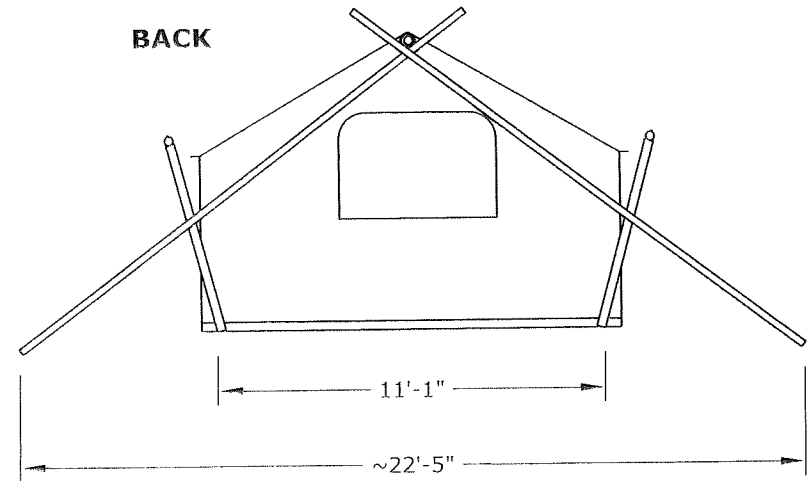
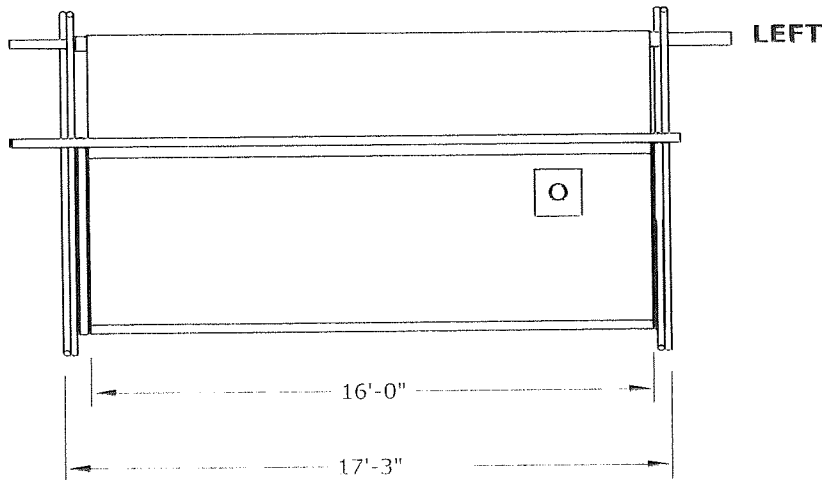



PRODUCT CODE

ESAF

PRODUCT NAME

EVENT SAFARI - FOOTPRINT

